

High performance angle gearboxes

GÜDEL

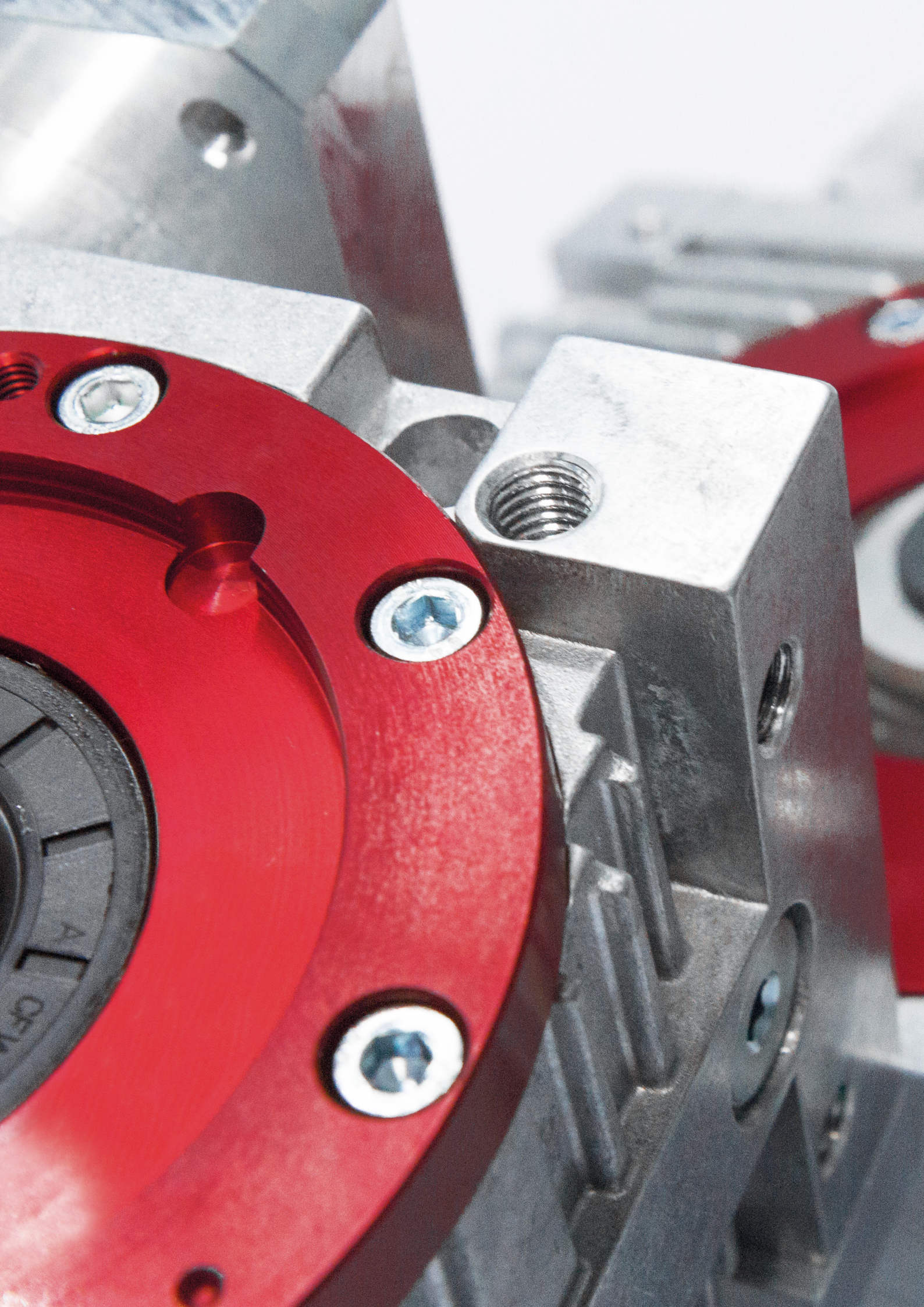

Content

High performance angle gearboxes

Product overview All about five – All sizes at a glance	6
Precision grades Precise or extra-precise – A choice of two grades.....	8
Preselection Make your decision – Speed & torque	10
Inputs Standard inputs.....	12
Outputs Meeting all your needs – We offer the appropriate outputs.....	14
Additional benefits Adaptation options – Preferably as a package	16
Integration Universal fastening methods & positioning of your gearbox	18
Function package Your ideal drive train – Gearbox, rack & pinion.....	20
Configuration Find your appropriate size & configuration	22

Technical data sheets

Size 030.....	26
Size 045	34
Size 060	42
Size 090	50
Size 120.....	58

Your ideal drive train

Pinions – Helical teeth.....	68
Racks – Helical teeth.....	69
Pinions – Straight teeth.....	74
Racks – Straight teeth.....	75

Technical information

Order reference Generate the code of your gearbox.....	80
Order reference Choose your appropriate motor interface.....	82
Flowcharts Calculate your gearbox	84
Flowcharts Find your ideal drive train	86

Güdel worldwide

Contacts.....	90
---------------	----

All about five – All sizes at a glance

Our portfolio of high-performance angle gearboxes covers five different sizes. The names for the different sizes correspond to the center distance (in mm) between the input and output shafts: 030, 045, 060, 090 and 120. An extremely broad choice of gear ratios – thirteen in total, ranging from 2 to 60 – enables you to cover the most common areas of application.

Our high-performance angle gearboxes are ideal for all types of angular drives. They are used in mechanical engineering, handling technology and various process applications, and are characterized by their high quality, long service life and minimal maintenance requirements. Our high-performance angle gearboxes are ideally suited for harsh working environments. They are dirt-resistant and can also cope with applications that use very long strokes. Their cooling fins guarantee optimal heat dissipation.

We always have a sufficient quantity of all parts for all sizes of our high-performance angle gearboxes in stock so that we can guarantee quick delivery even at short notice.

090

Sizes

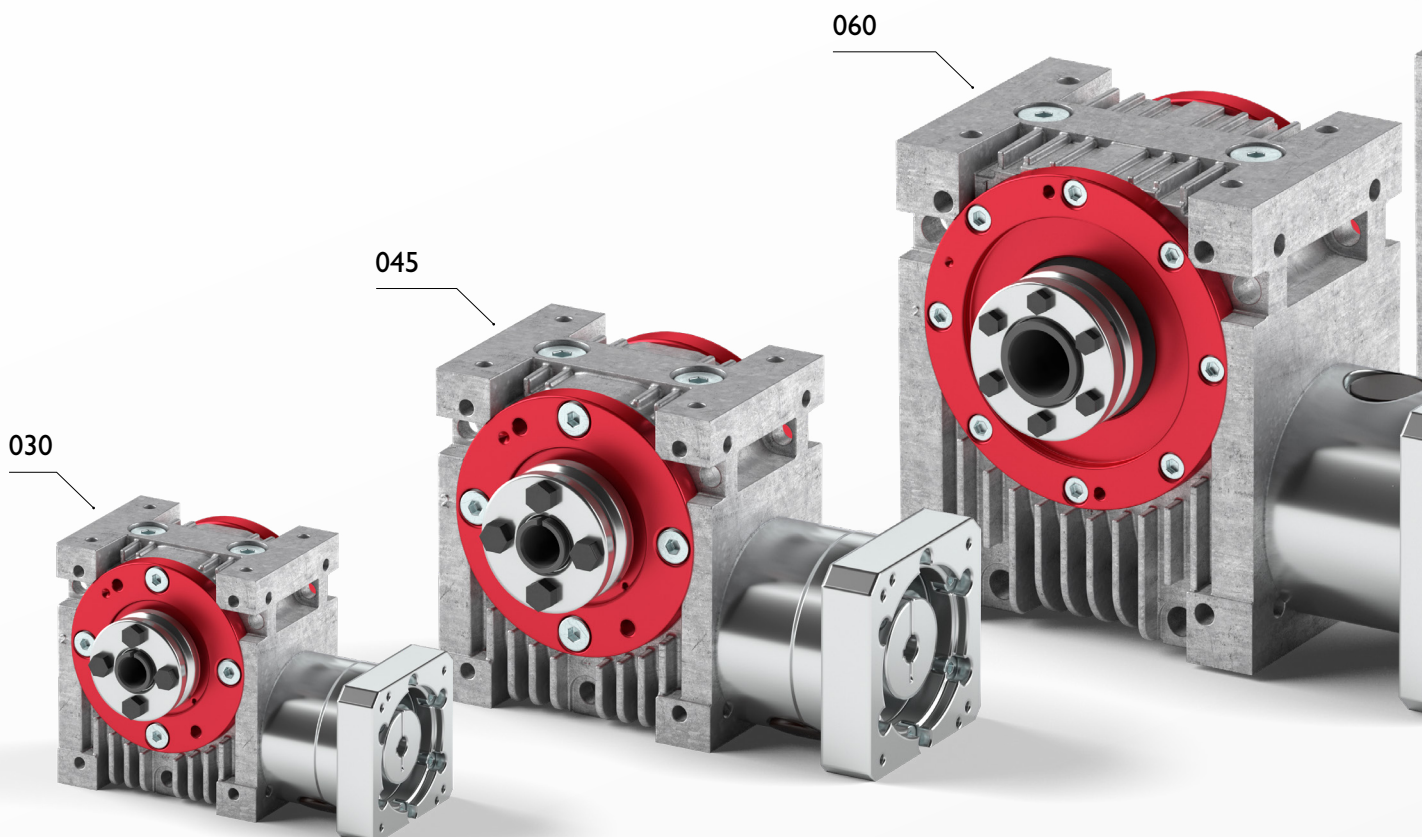

Our modular principle allows all the input and output variants within a given size to be combined however you want, in order to achieve a result that is perfectly tuned to your specific application needs. Depending on the gear ratio, you can use the self-locking or no self-locking properties, or the transition area for your requirements.

In addition to their high availability and universal build, our high-performance angle gearboxes also boast special design features such as: closed casing for a range of installation positions, the option to adjust the precision (backlash), great flexibility as regards the motor choice and coupling (motor – gearbox), lubrication, a range of mounting options on all sides, centering at the output and options for centering at the input. All these design features help you to perfectly integrate the angle gearboxes into your machinery or equipment.

We manufacture and assemble the gearboxes in-house, using state-of-the-art production equipment. They are then thoroughly tested in accordance with our rigorous quality standards.

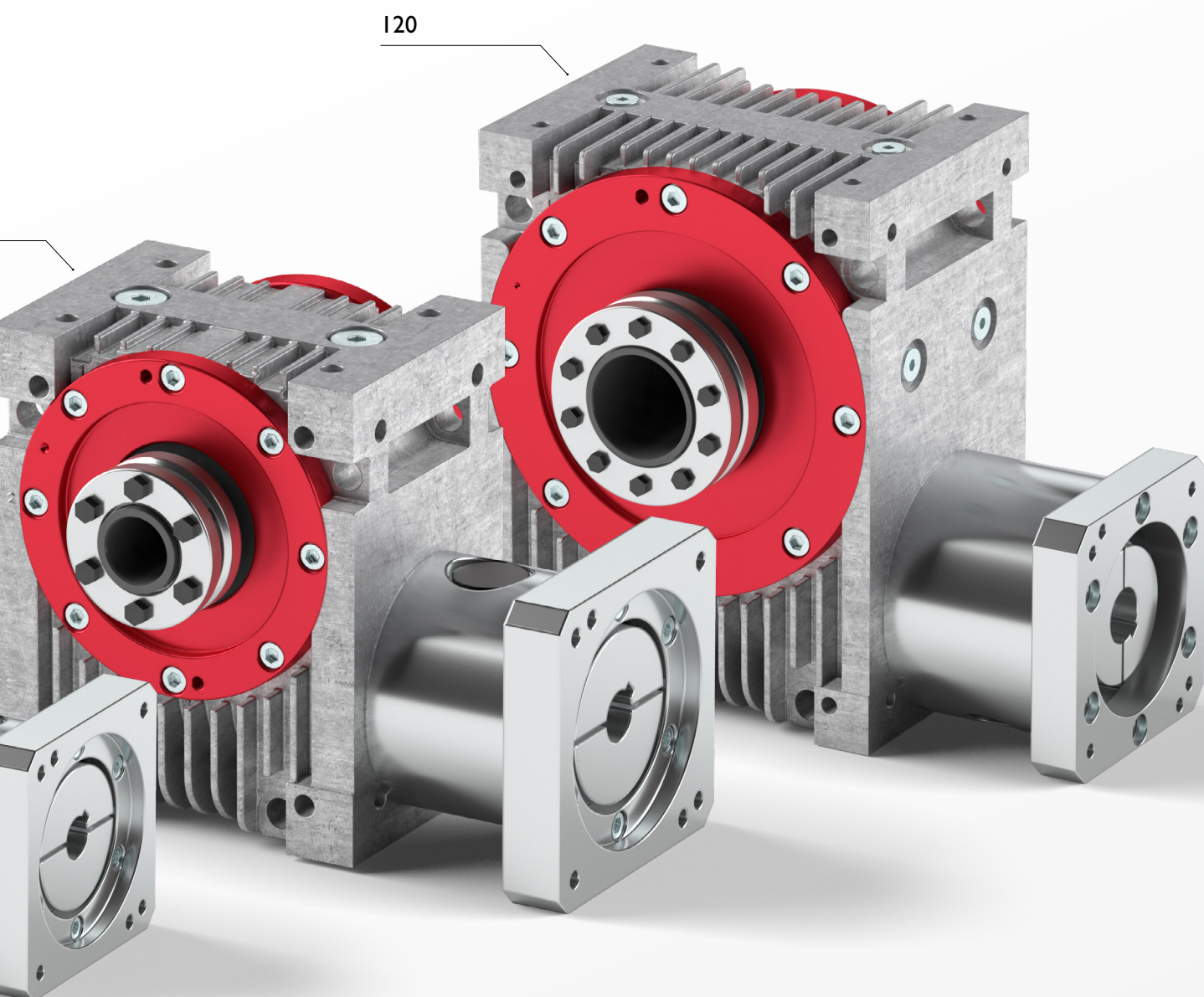

Precise or extra-precise – A choice of two grades

Our high-performance angle gearboxes are available in two precision grades. Precision grade PS stands for standard backlash and precision grade PR for reduced backlash.

On the higher-precision gearbox (PR), the backlash can be more finely adjusted, with the backlash corresponding to the output shaft's angle of twist (arcmin). To allow for precision re-adjustments, an easy-to-use eccentric system in the output shaft area is standard on all gearboxes, making it possible to set and re-adjust the backlash quickly and easily.

The gearboxes are preset in the factory to the selected precision grade. No re-adjustment is necessary under normal operating conditions, as the increase in backlash should be minimal for gearboxes that are correctly dimensioned and maintained. Nevertheless, with our re-adjustment mechanism you can reset the backlash quickly, easily and safely over the entire service life – guaranteed. And there is no need to open up the gearbox to do this. You can easily make the re-adjustment yourself using the symmetric rotation of the eccentric flanges on either side of the output bearing. The position markings on the casing help you to define the eccentric position.

Adjustment backlash

The backlash can be re-adjusted via the eccentric cover: Rotate both covers synchronously in the direction of the next higher number, (marked in red). Intermediate positions are possible.

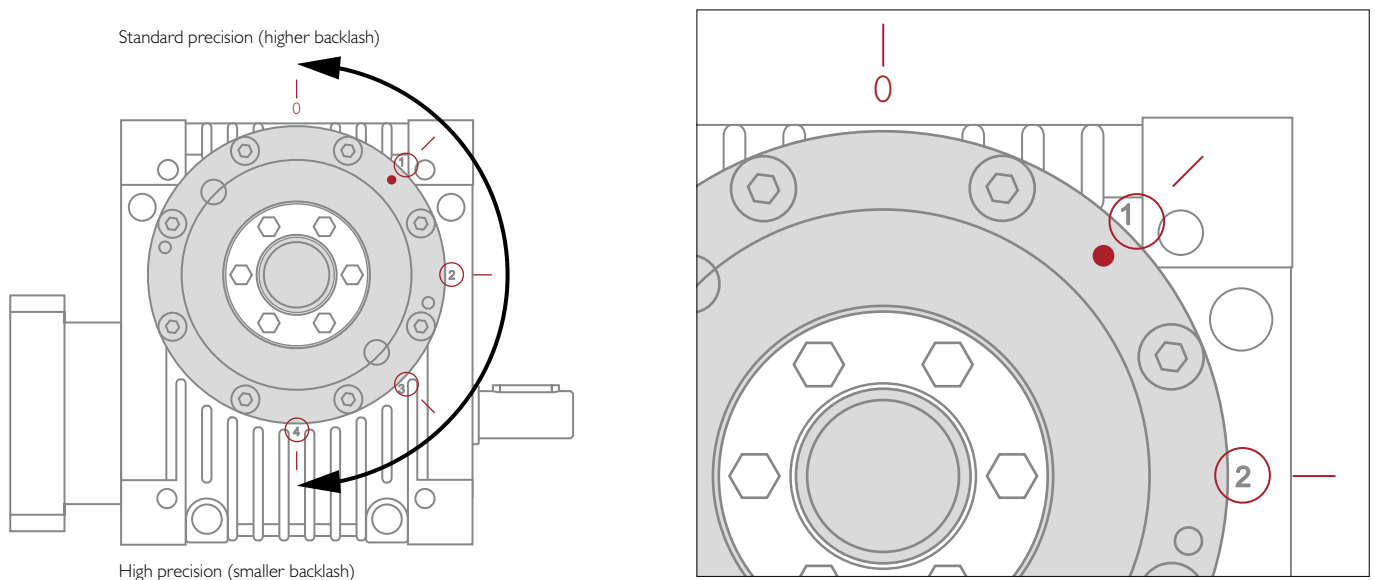

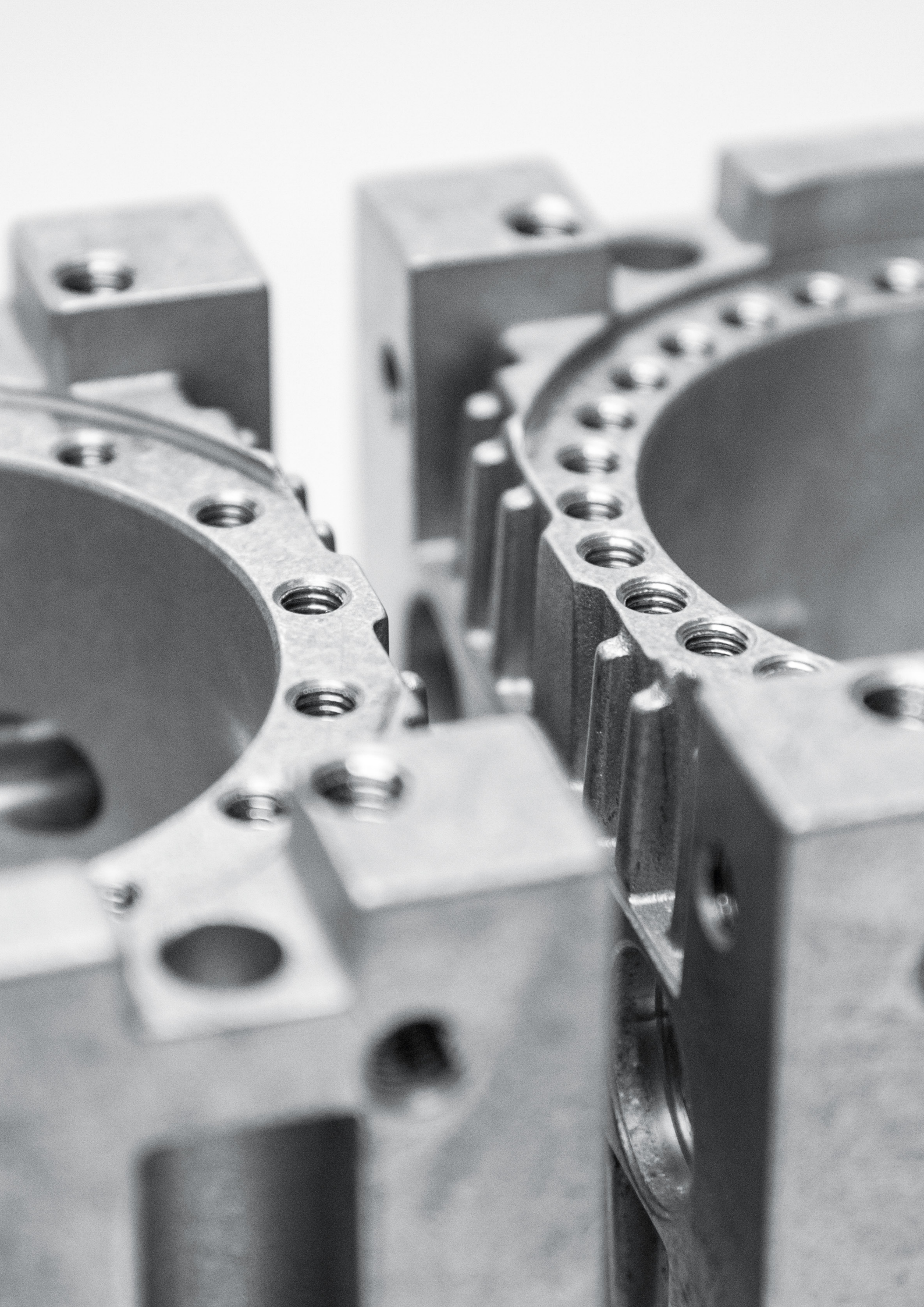

Make your decision – Speed & torque

On this double page you can narrow down your choice between our highperformance angle gearboxes. Make a selection based on your key requirements – speed and torque – to find the correct gearbox for your application.

Ratio & precision grades

Precision grade PS – standard backlash [arcmin]

PS														
Size	Ratio i										transition area		self-locking	
	2	3	4	5	no self-locking		8	10	13.33	16	24	30	47	60
030	22	18	16	16	14	12	12	12	12	12	12	11	11	11
045	15	12	11	11	9	8	8	8	8	8	8	7	7	7
060	13	10	9	9	8	7	7	7	7	7	7	6	6	6
090	10	8	7	7	6	6	6	6	6	6	6	5	5	5
120	8	7	6	6	5	5	5	5	5	5	5	4	4	4

Precision grade PR – reduced backlash [arcmin]

PR														
Size	Ratio i										transition area		self-locking	
	2	3	4	5	no self-locking		8	10	13.33	16	24	30	47	60
045	10	8	7	7	6	5.5	5.5	5.5	5.5	5.5	5.5	5	5	5
060	9	7	6	6	5	4.5	4.5	4.5	4.5	4.5	4.5	4	4	4
090	6.5	5	4.5	4	4	3.5	3.5	3.5	3.5	3.5	3.5	3	3	3
120	5.5	4.5	4	3.5	3	3	3	3	3	3	3	2.5	2.5	2.5

The following diagrams offer you a preselection of sizes based on the most important performance parameters, maximum speed and maximum torque. The values apply for a sample ratio $i = 24$.

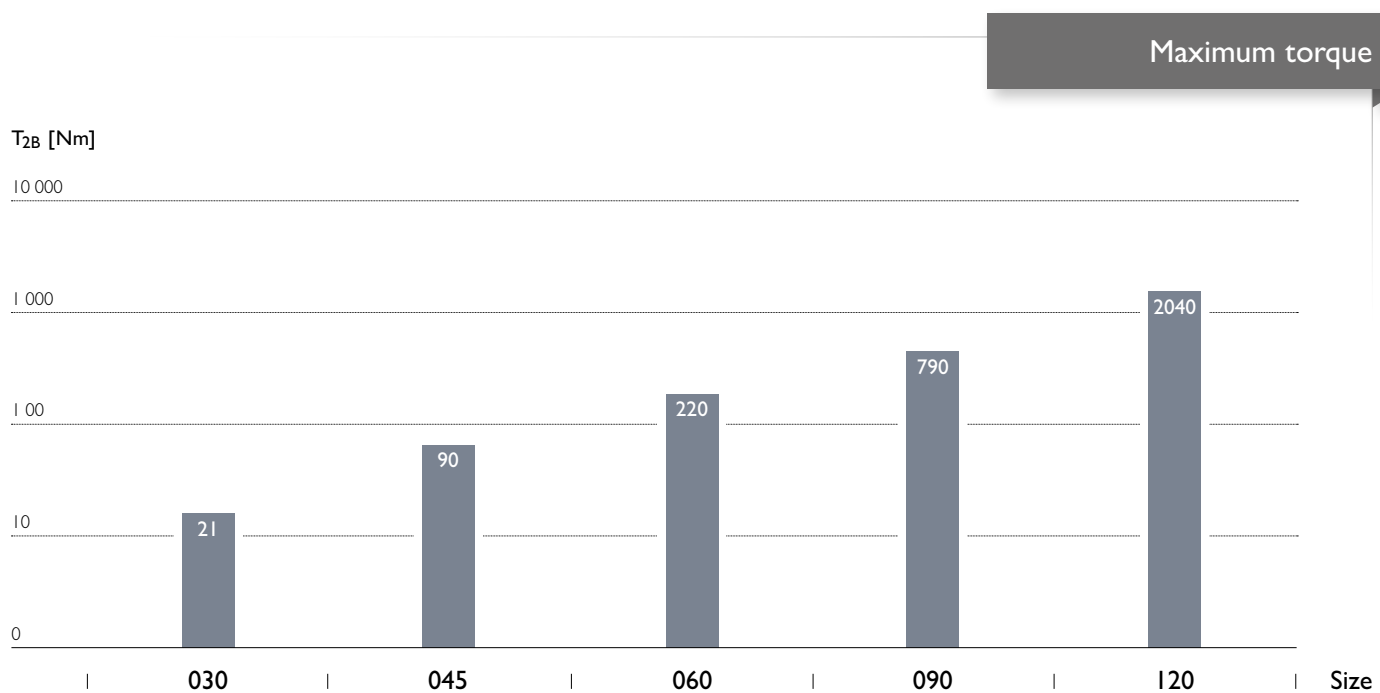
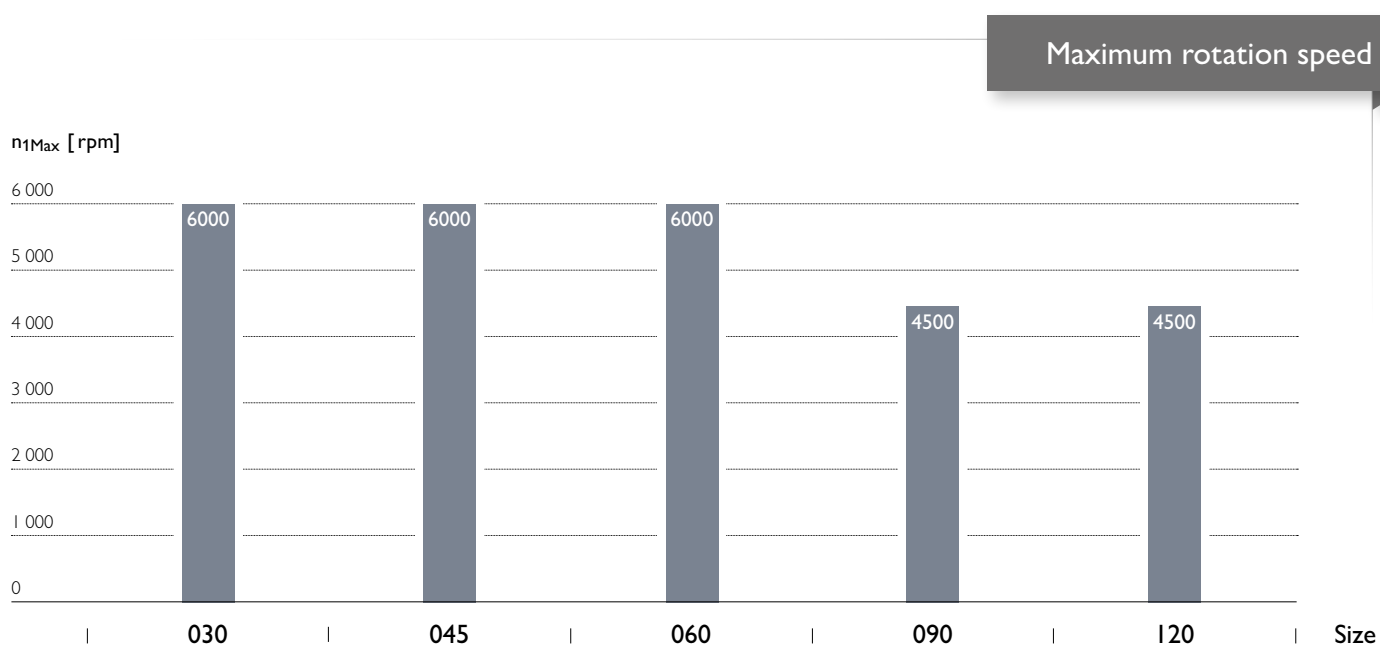

Standard inputs

Choose between two different input varieties. Our two standard inputs come with either a motor flange or a drive shaft.

On the input side of the gearbox there is a drive shaft with keyway, and on the output there is a shrink disc coupling. Optional, an maintenance free elastomer coupling together with a motor flange is available. These guarantee a backlash-free power train and make it possible to attach a variety of motors. Their dimensions are determined by the mounting dimensions of the motors.

Inputs with drive shaft

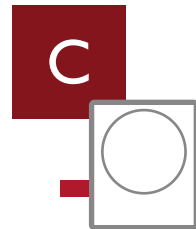
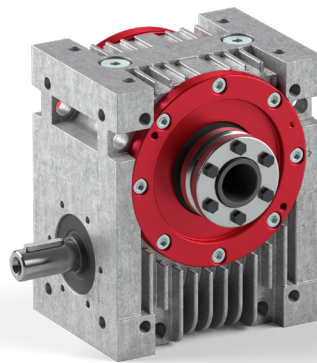

Drive shaft

Optional motor flange

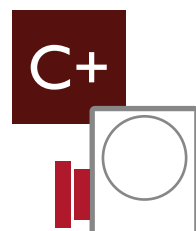
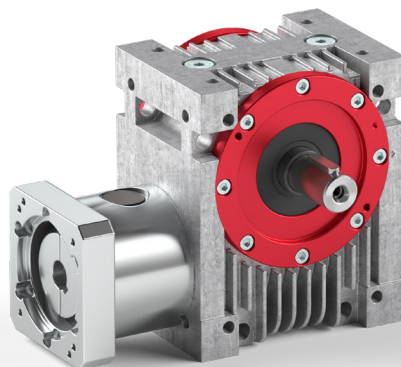

Motor flange

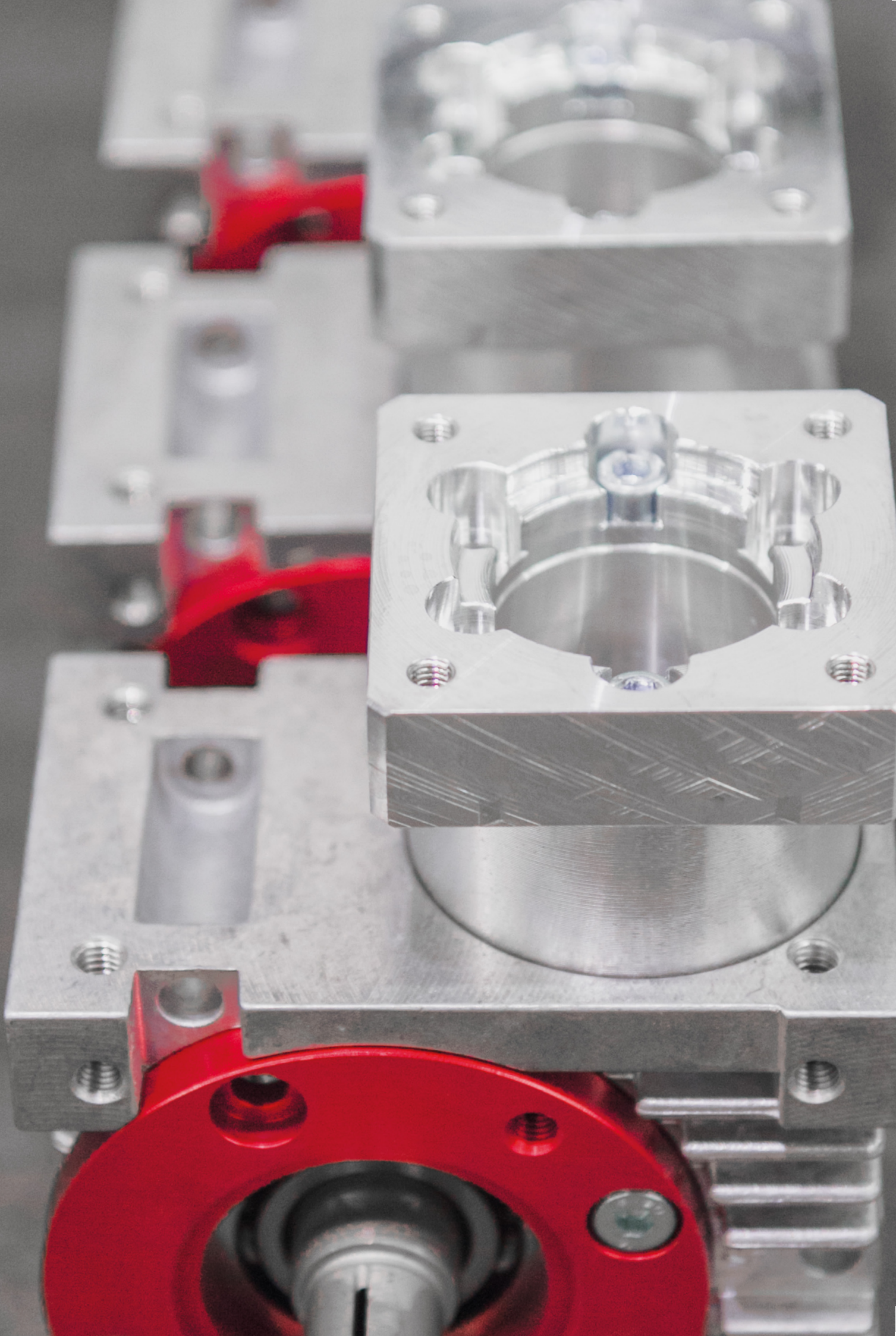

Meeting all your needs – We offer the appropriate outputs

With our comprehensive range of outputs, you are ideally equipped for every application. Our standard outputs allow you to choose whether you prefer the shrink disc on the left, or left-hand side, or even on both sides.

We offer three standard outputs and four optional outputs. The standard outputs include a hollow shaft with shrink disc on the left, hollow shaft with output on the right, and a hollow shaft with shrink disc on both sides of the output. The optional outputs include a shaft on the left of the output, on the right of the output, on both sides of the output, and a hollow shaft on both sides of the output.

Outputs with shrink disc

Shrink disc
to the left (1),
to the right (2)* or
on both sides (3)

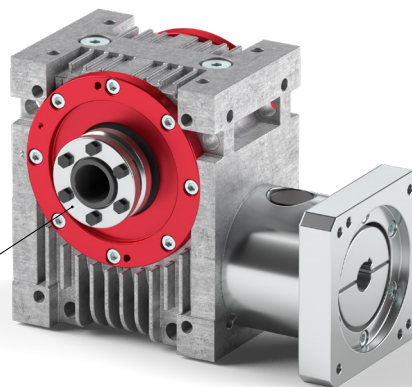

* Position right and left is defined by the motor view.



Outputs with shaft

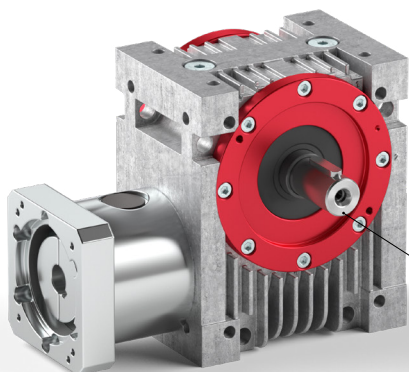
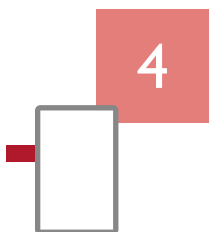

Shaft on the output
to the left (4),
to the right (5)* or
on both sides (6)

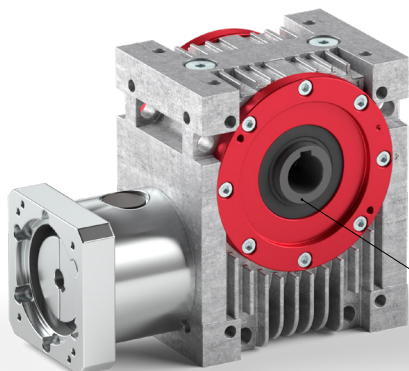
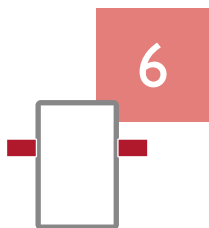

Hollow shaft on the output
on both sides (7)

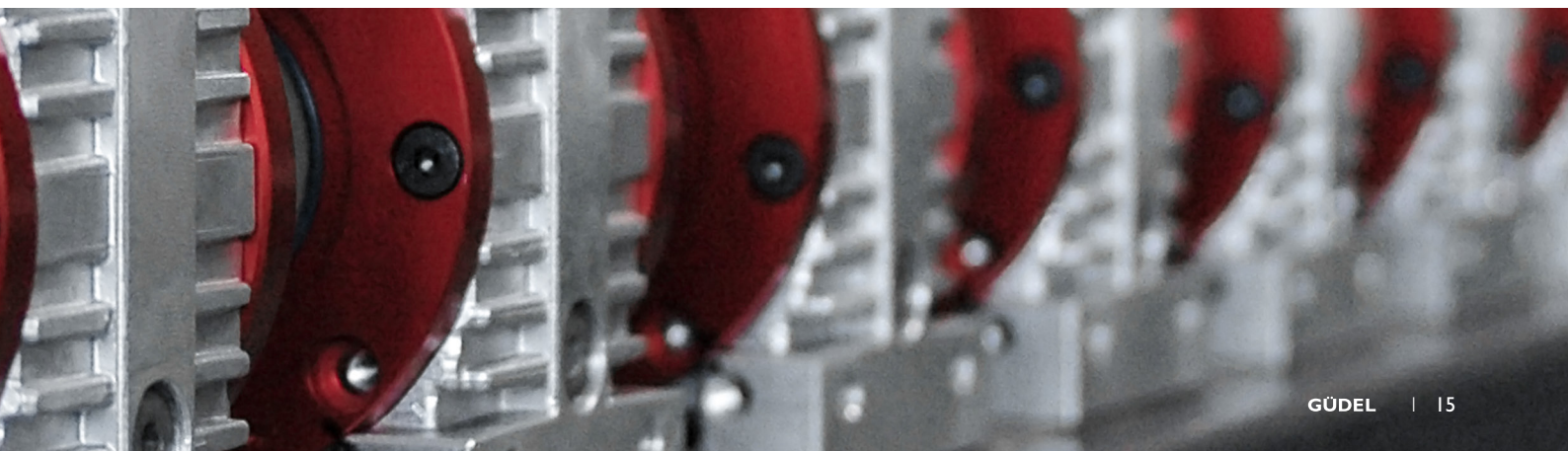

Adaptation options – Preferably as a package

Standard outputs can easily be expanded to packages with our pinion and our output flange. The following choices are available: Shrink disc on the left with pinion and output flange, shrink disc on the right with pinion and output flange. In gearboxes with shrink discs on both sides of the output, an output flange can be positioned on either the left or the right side.

Package

Good support for the
output bearing must be ensured.

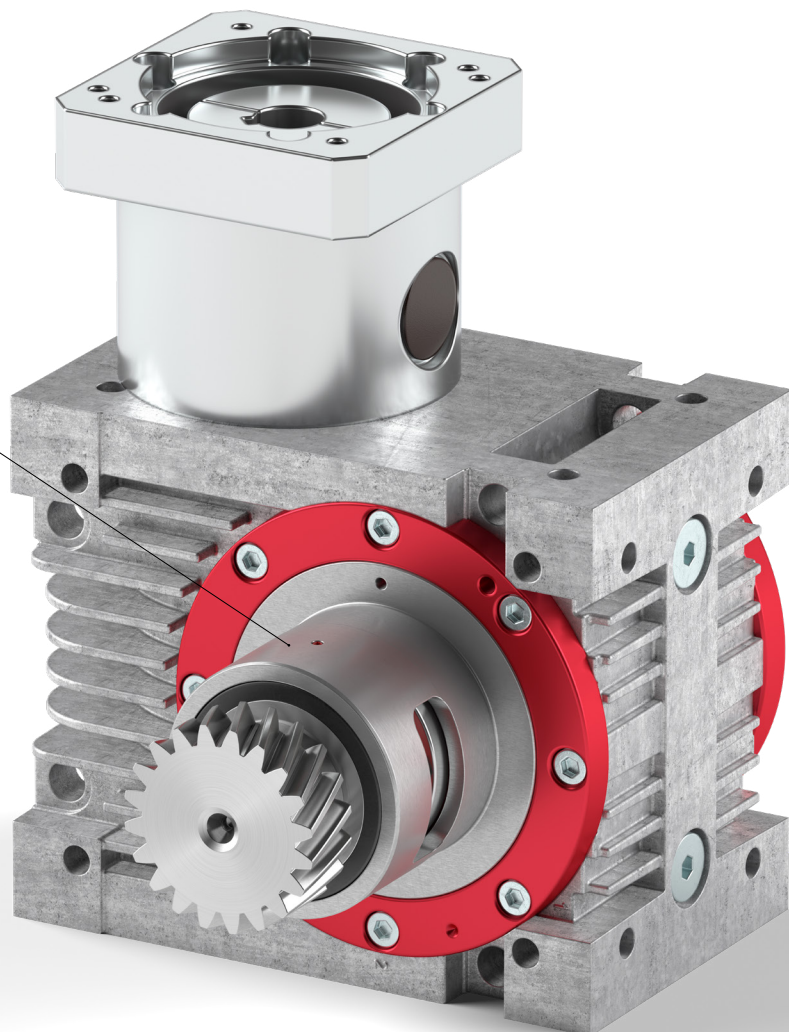
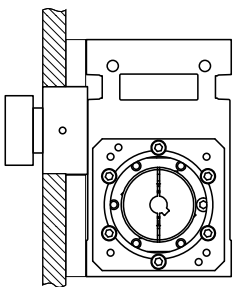

Spacer elements

The optional distance elements enable you to attach large, powerful motors to your gearbox easily and without having to carry out any complex additional work on your existing component structure. Depending on the size, we provide spacing strips or plates as assembly elements.

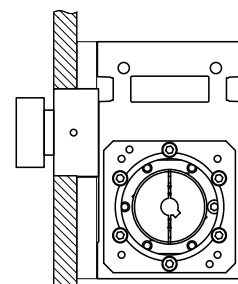

Additional benefits

Precision centering option thanks to an additional function

Our high-performance angle gearboxes have a precise centering collar in the eccentric cover on the output side. This centering collar enables you to accurately align and mount the gearbox onto a shaft or bore hole on the output side.

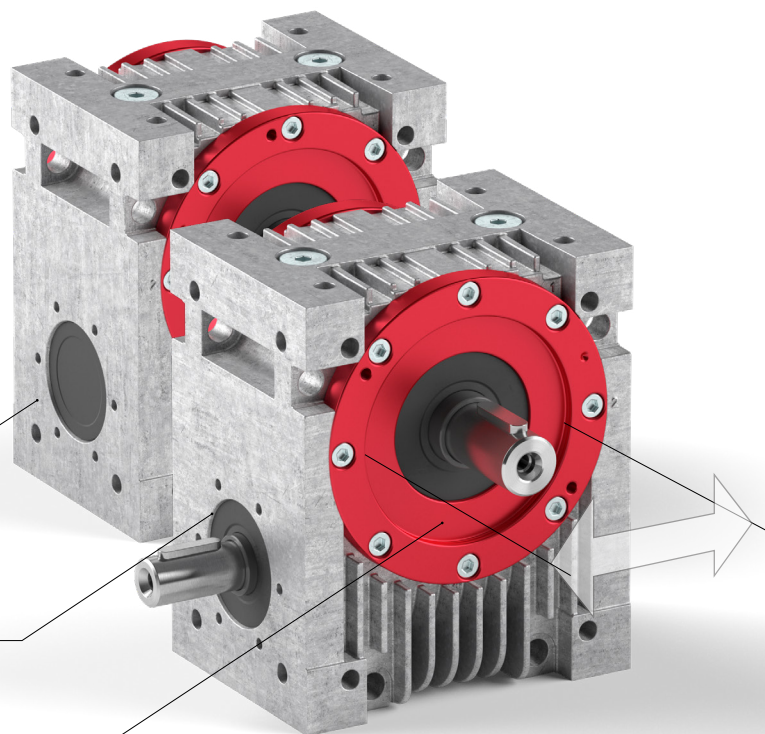

Cover shifted inwards

Shaft Seal shifted inwards

Centering collar on the eccentric cover

Universal fastening methods & positioning of your gearbox

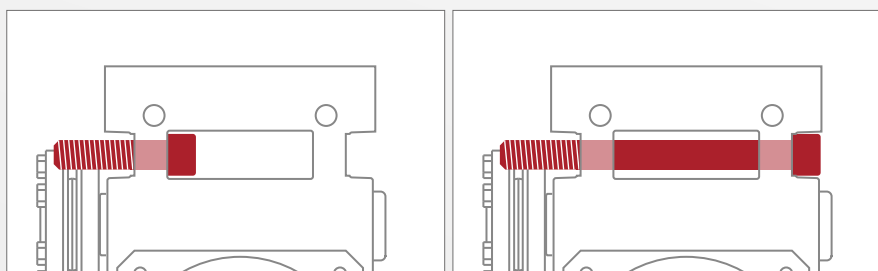
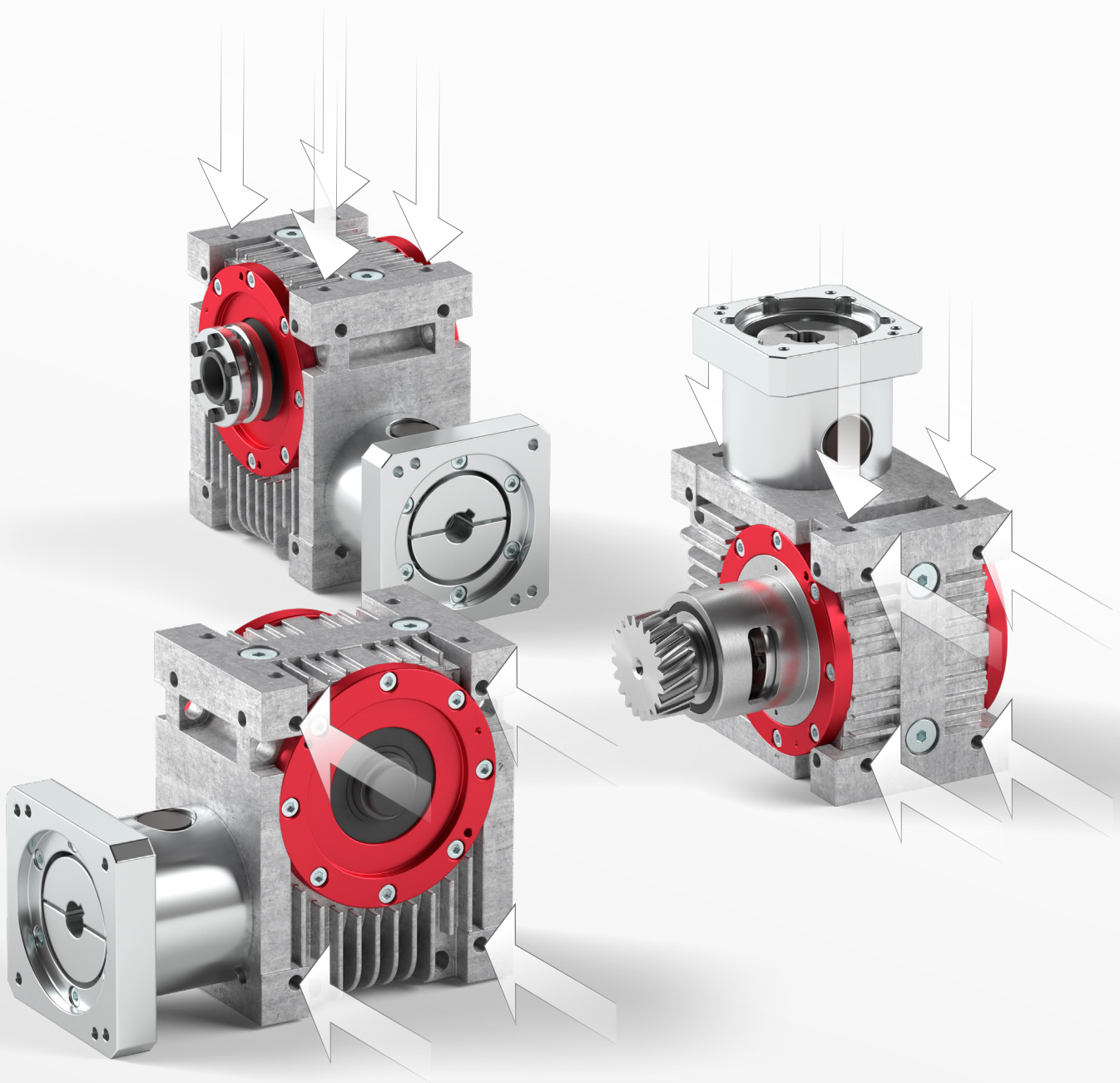

A huge range of fastening methods is possible, for example with long or short screws, as well as as through the multi-directional thread in the casing.

SS vertical worm standing

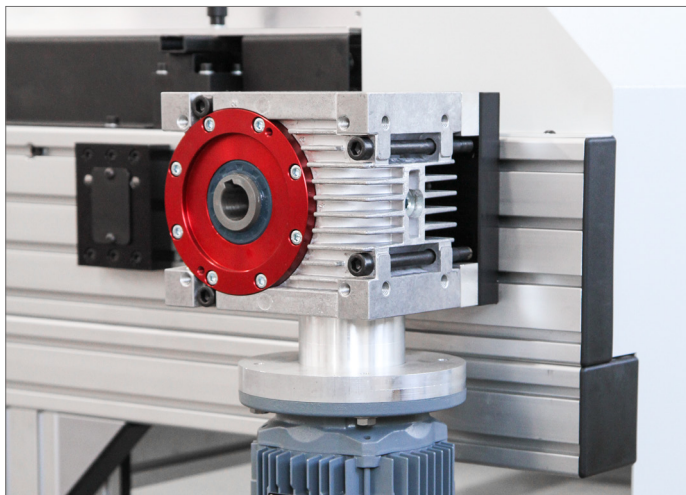
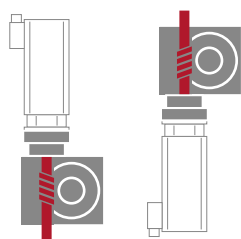

SU horizontal worm below

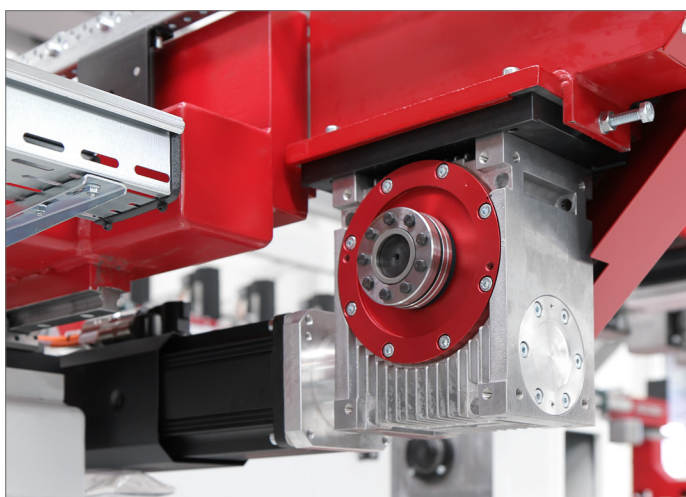
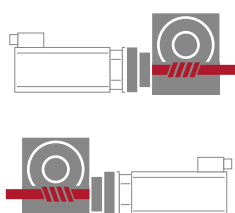

SL horizontal worm side

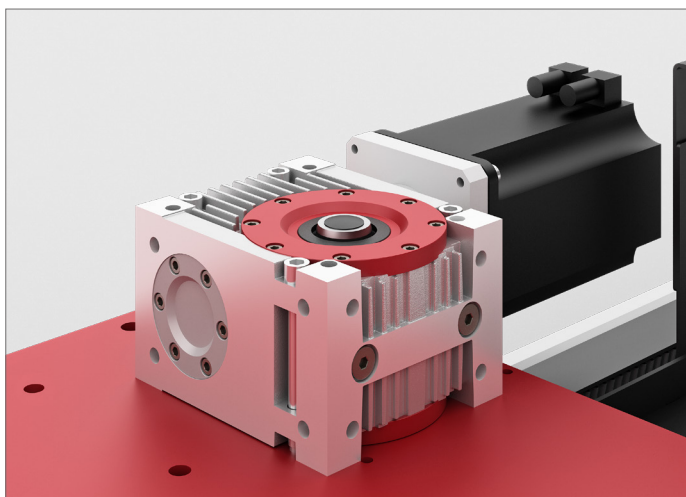
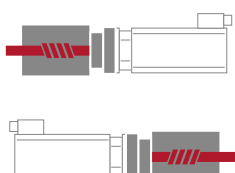

SO horizontal worm top

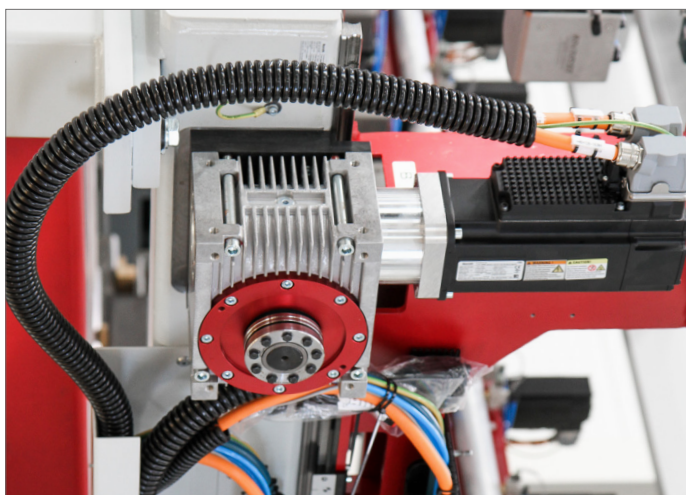
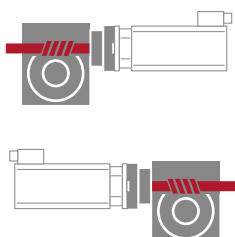

Your ideal drive train – Gearbox, rack & pinion

Our gearboxes can be easily combined with our racks and pinions into complete functional packages. The components from our product portfolio are ideal for your high-performance drive train.

For linear systems with a rack-and-pinion drive, you can integrate high-precision, powerful drive pinions directly into our high-performance angle gearbox. The pinions are connected to the output with no backlash via non-positive tensioning elements.

For particularly demanding drive trains which are subject to high stresses, the integrated pinion can be given additional support from an output flange. There is an additional strong bearing in this output flange. This enables you to significantly increase the load-bearing capacity, service life, and rigidity of the pinion bearing. We recommend that the output flange be supported in a precision bore hole.

We offer our modular pinion and rack portfolio in different materials so that they can also be used in the food and chemical industry. You can also combine your selected gearbox with other Güdel products.



HPG 060 High performance angle gearboxes

Output flange including bearing & pinion

Options & accessories High performance angle gearboxes

Spacer elements

Shrink disc

Elastomer coupling

GÜDEL

With pinion special solutions on request.

Shrink disc

Elastomer coupling

Model	Max. Torque	Max. Speed	Max. Power	Max. Load	Max. Weight	Max. Length	Max. Width	Max. Height
Model 1	1000	1500	1500	1000	1000	1000	1000	1000
Model 2	2000	1500	3000	2000	2000	2000	2000	2000
Model 3	3000	1500	4500	3000	3000	3000	3000	3000

Detailed information on the technical data sheets package, options & accessories.

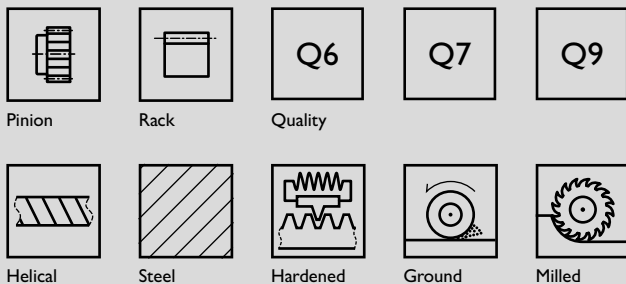

	High-end applications	Standard applications	Basic applications
Rack	Q6	Q7	Q9
Gearbox	PR	PR	PS
Precision	High		Standard
Feed force	High	Medium	Elevated

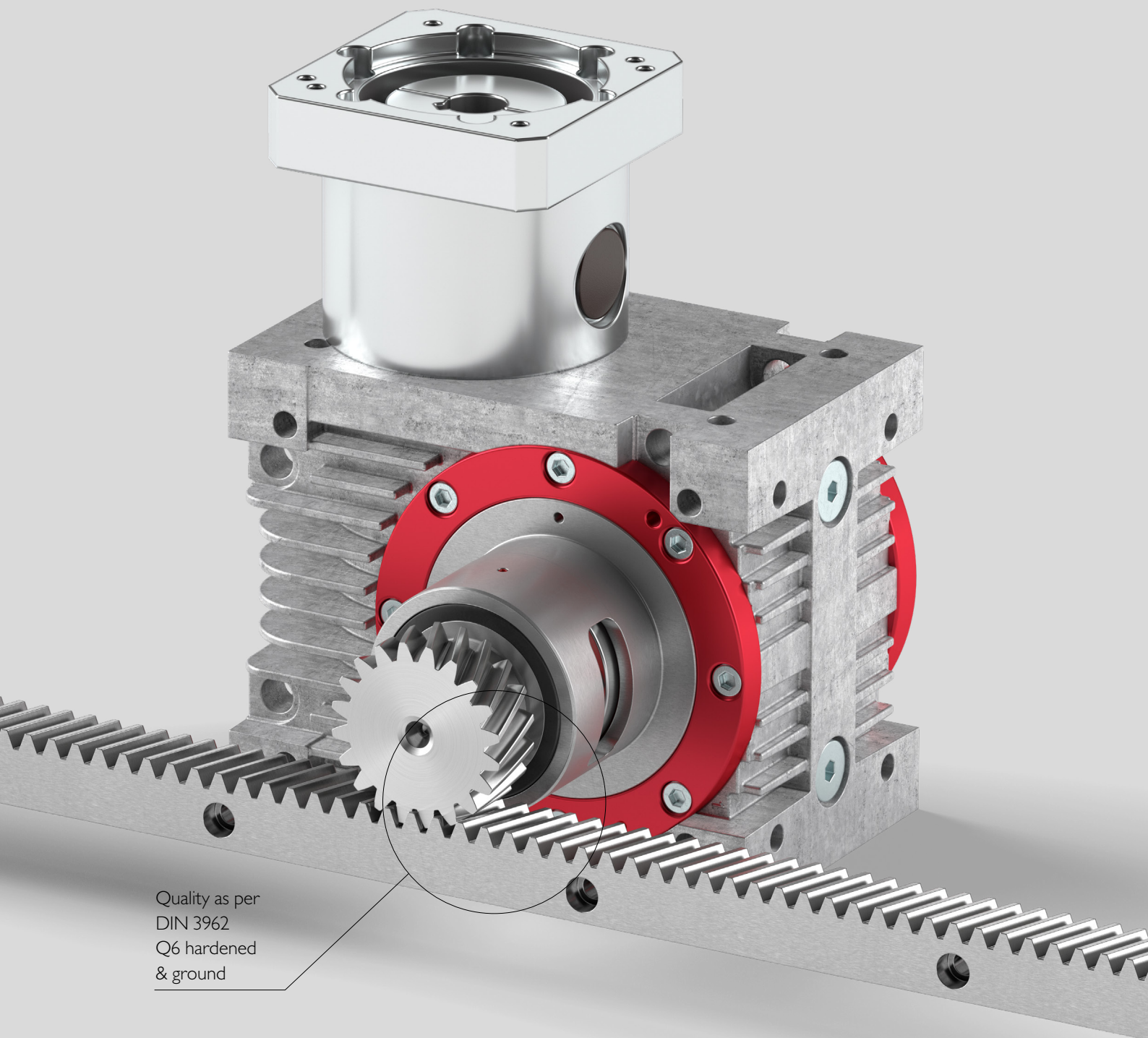

Find your appropriate size & configuration

Hollow shaft with shrink disc

left	right	both sides
------	-------	------------

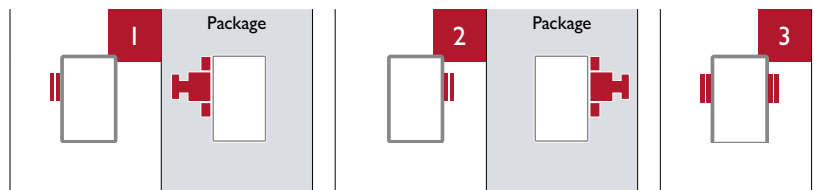

Standard inputs with motor flange

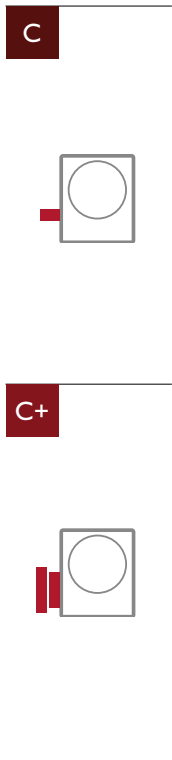

Size	left		right		both sides	
	Page	Page	Page	Page		
C	030	26–27	28–29	26–27	28–29	26–27
	045	34–35	36–37	34–35	36–37	34–35
	060	42–43	44–45	42–43	44–45	42–43
	090	50–51	52–53	50–51	52–53	50–51
	120	58–59	60–61	58–59	60–61	58–59
C+	030	26–27	28–29	26–27	28–29	26–27
	045	34–35	36–37	34–35	36–37	34–35
	060	42–43	44–45	42–43	44–45	42–43
	090	50–51	52–53	50–51	52–53	50–51
	120	58–59	60–61	58–59	60–61	58–59

Output shaft

left	right	both sides
------	-------	------------

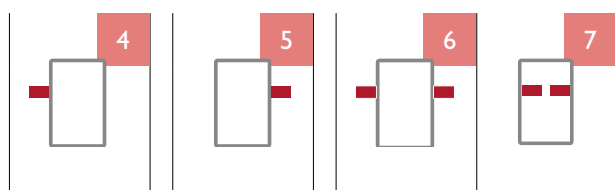

Page	Page	Page	Page
30-31	30-31	30-31	32-33
38-39	38-39	38-39	40-41
46-47	46-47	46-47	48-49
54-55	54-55	54-55	56-57
62-63	62-63	62-63	64-65
30-31	30-31	30-31	32-33
38-39	38-39	38-39	40-41
46-47	46-47	46-47	48-49
54-55	54-55	54-55	56-57
62-63	62-63	62-63	64-65

Your ideal drive train

Rack & pinion program

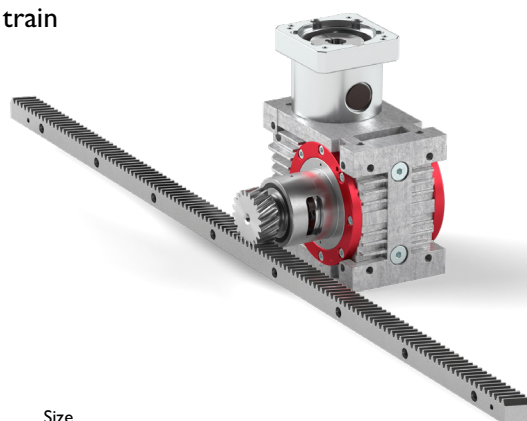
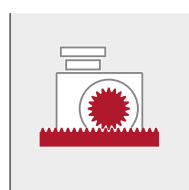

Page
68-76

Size	
030	C
045	
060	
090	
120	
030	C+
045	
060	
090	
120	

Drive shaft

Option with motor flange

Standard inputs with motor flange

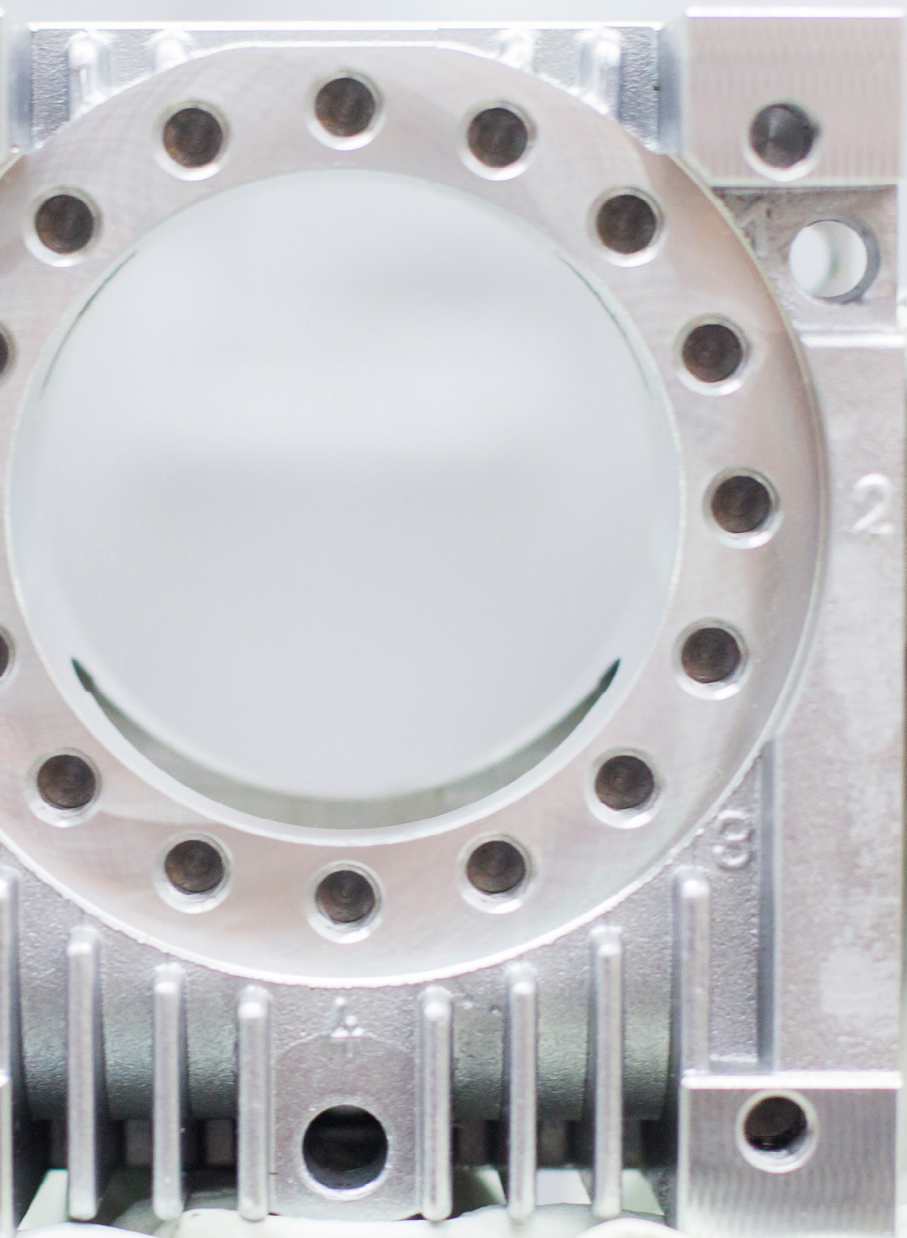

Technical data sheets

GÜDEL

Ratio	i		2	3	4	5	6	8	10	13.33	16	24	30	47	60	
Nominal torque at the output Efficiency	$n_{1N} = 500$ rpm	T_{2N}	[Nm]	12.9	17.9	20.1	19.2	16.9	19.4	17.9	17.5	19.5	19.0	8.6	18.8	8.6
		η	[%]	85	84	83	81	80	76	74	67	63	54	48	40	30
	$n_{1N} = 1000$ rpm	T_{2N}	[Nm]	11.3	16.0	18.3	17.5	15.5	17.9	16.6	16.2	18.1	17.6	8.6	17.5	8.6
		η	[%]	86	86	85	83	81	77	74	68	65	55	50	44	40
	$n_{1N} = 1500$ rpm	T_{2N}	[Nm]	10.0	14.4	16.7	16.2	14.3	16.6	15.4	15.1	16.9	16.4	8.6	16.3	8.6
		η	[%]	86	86	85	83	80	77	73	68	64	54	49	45	40
	$n_{1N} = 3000$ rpm	T_{2N}	[Nm]	7.4	11.2	13.3	13.1	11.7	13.7	12.8	12.6	14.0	13.7	8.6	13.6	8.6
		η	[%]	84	84	83	81	77	74	71	67	62	53	48	44	40
	$n_{1N} = 4500$ rpm	T_{2N}	[Nm]	5.9	9.2	11.0	11.0	9.9	11.6	10.9	10.8	12.0	11.8	10.0	11.7	10.0
		η	[%]	81	82	81	78	76	73	69	65	60	51	47	42	37
	$n_{1N} = 6000$ rpm	T_{2N}	[Nm]	4.9	7.8	9.4	9.4	8.6	10.1	9.5	9.4	10.5	10.3	10.0	10.2	10.0
		η	[%]	79	79	78	77	75	72	68	62	56	47	42	37	33
Max. acceleration torque		T_{2B}	[Nm]	13	21								10	21	10	
Emergency stop torque		T_{2Not}	[Nm]	35								20	35	20		
Idling torque ^{a)}		T_{012}	[Nm]	0.65			0.6			0.5						
Max. input speed		n_{1Max}	[rpm]	6000												
Max. backlash ^{b)} at the output	PS	j_c	[arcmin]	<22	<18	<16	<16	<14	<12					<11		
Torsional rigidity from output to input		C_{t21}	[Nm/arcmin]	0.3	0.45	0.58	0.63	0.66	0.68	0.72	0.74	0.78	0.8	0.75	0.85	0.75
Stability at the output		C_{2K}	[Nm/arcmin]	27												
Max. axial force ^{c)d)} at the output		F_{a2max}	[N]	910	1200	1500	1800	2200	2100	2300	2500	2700	2900	3100	2900	3100
Max. radial force ^{c)e)} at the output		F_{r2max}	[N]	640	740	850	970	1100	980	1000	1000	1100	1200	1300	1300	1300
Max. overturning torque ^{c)} at the output		M_{2max}	[Nm]	32	37	42	48	54	49	50	52	54	60	67	65	67
Max. axial force ^{c)d)} at the input		F_{a1max}	[N]	890	740	700	780	890	820	890	910	860	880	1100	890	1100
Max. radial force ^{c)f)} at the input		F_{r1max}	[N]	280	270	280	300	320	320	330	340	330	340	360	340	360
Mass moment of inertia ^{g)}		J_1	[10 ⁻⁷ kg m ²]	230	110	68	49	38	28	23	19	18	16	15	15	15
Mass moment of inertia ^{g) h)}		J_1	[10 ⁻⁷ kg m ²]	280	161	119	100	89	79	74	70	69	67	66	66	65
Mass moment of inertia ^{g) i)}		J_1	[10 ⁻⁷ kg m ²]	510	390	348	329	318	308	303	299	298	296	295	295	295
Service life		L_h	[h]	25000												
Weight without motor components		m	[kg]	1.7												
Weight with motor components		m	[kg]	≈ 2.2												
Max. permissible housing temperature			[°C]	+90												
Ambient temperature			[°C]	-15 up to +50												
Lubrication	synthetic gear oil (as per DIN 51502: CLP PG 460)															
Painting	None															
Protection class	IP65															

- a) approximate, at $n_1 = 3000$ rpm and operating temperature.
- b) Precision grade PS (standard backlash) for classic mechanical engineering applications.
- c) Bearing forces: Values valid at $n_1 = 3000$ rpm; $\frac{2}{3} T_{2N}$ and duty cycle of 40%. Consult with Güdel for composite bearing forces, axial and radial forces.
- c) d) in relation to shaft center.
- c) e) at a distance of 50 mm from the middle of the casing.
- c) f) at a distance of 60 mm from the middle of the casing.
- g) in relation to the input, including shrink disc at the output (output 1 & 2), with two shrink discs (output 3) increase values by 360/1P.
- g) h) including elastomer coupling 5103-14 (calculated with drilled hole for motor shaft-Ø15)
- g) i) including elastomer coupling 5103-19 (calculated with drilled hole for motor shaft-Ø15)

Bearing forces

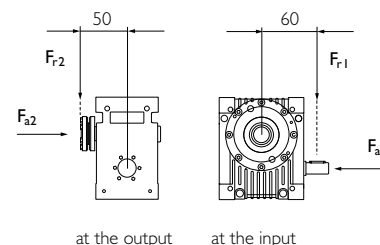

Package

		Output flange including bearing & pinion					
Radial rigidity	C_3	[N/mm]	22000				
Speed	n_{2N}	[rpm]	1500	750	400	150	100
Max. radial force ^{j)}	F_{rmax}	[N]	1100	1350	1500	1600	1700

j) Bearing forces: Values valid at duty cycle of 40% at a distance of 10mm from the end of the bearing.

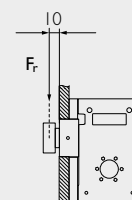

Detailed information about the package, options & accessories on pages 28 and 29.

Output flange including bearing & pinion a)

Package

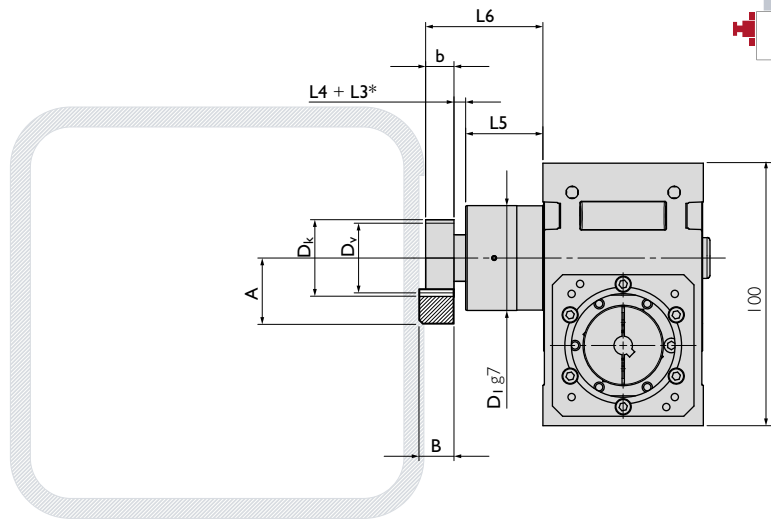
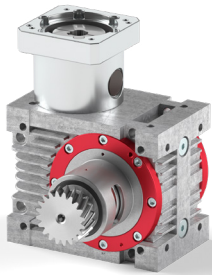

Example HPG 030 C2 Package

Package

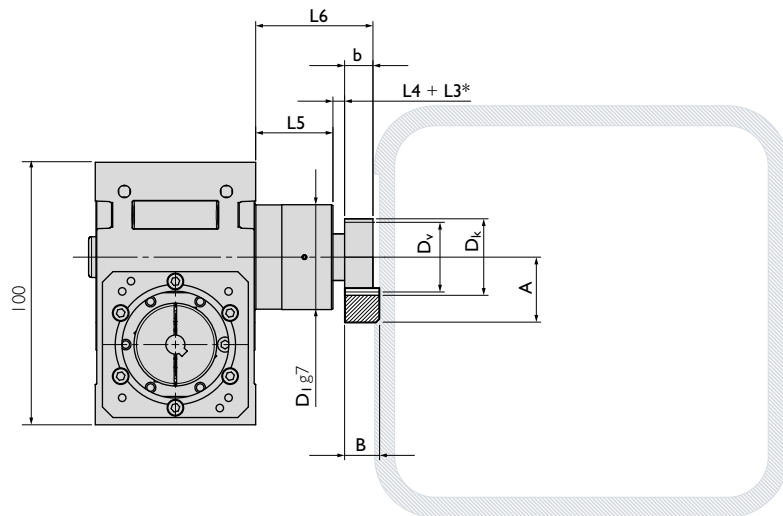

a) The output flange must be supported by the customer supplied equipment at the bearing end (D1), in a hole with an H8 tolerance.

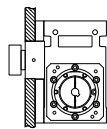

* L3 for additional distance ring.

Geometric information

Helical modular pitch	Part. No.	m_n	P_t	z	A	b	B	D_k	D_0	D_v	D_1	L4	L5	L6
Pinion 1	211116	1.5	5.00	16	30.680	20	19	29.36	25.465	26.365	47	4.5	38	62.5
													43	67.5

m_n : Normal module, P_t : Transverse pitch [mm], z : Number of teeth, D_v : Pitch circle diameter for design, D_0 : Pitch circle diameter for calculation

Straight modular pitch	Part. No.	m_n	P_n	z	A	b	B	D_k	D_0	D_v	D_1	L4	L5	L6
Pinion 2	201116	1.5	4.72	16	29.95	20	19	27.90	24.000	24.900	47	4.5	38	62.5
													43	67.5

m_n : Normal module, P_n : Normal pitch [mm], z : Number of teeth, D_v : Pitch circle diameter for design, D_0 : Pitch circle diameter for calculation

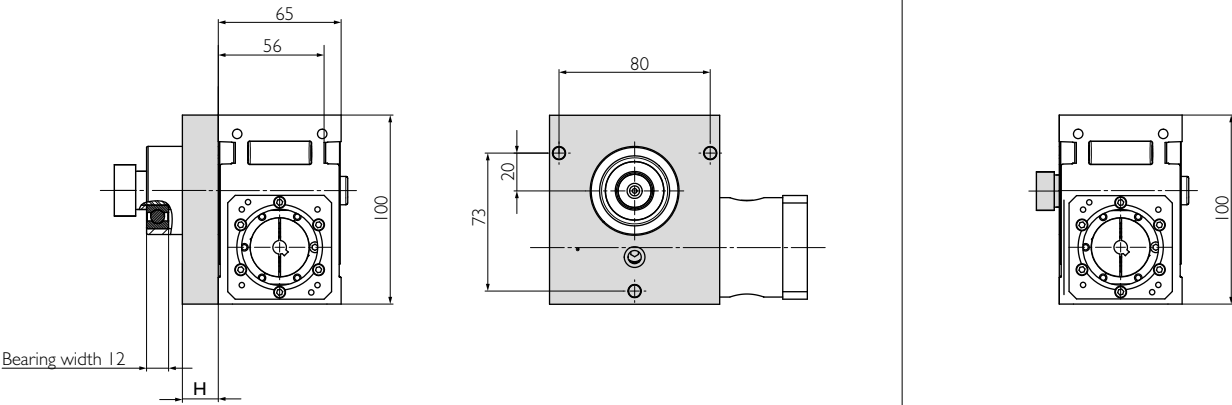
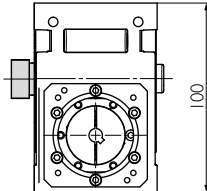
<p>Spacer elements</p> 	<p>With pinion special solutions on request</p> 
--	--

Casing can only be fastened with long screws as per the bore hole pattern.
Screws M6 of length 56mm + H + thread depth, tightening torque 9Nm.

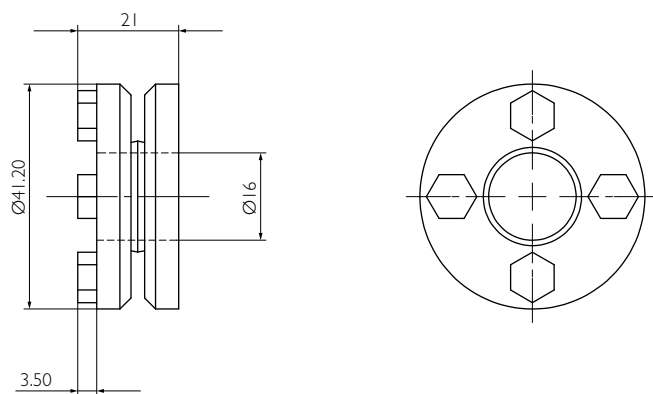
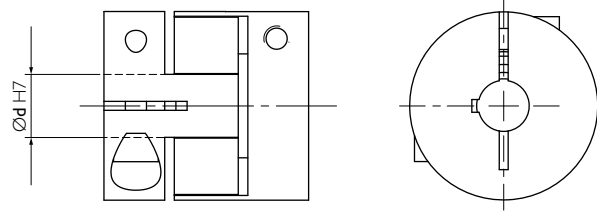
<p>Shrink disc</p> 	<p>Elastomer coupling</p> 
---	---

For more details see **Motor Interface** on page 84 et. seq.

Your ideal drive train

Our function package with high-performance angle gearbox, output flange, pinion and rack by Güdel.

			Pinion 1			Pinion 2
			Q6	Q7	Q9	Q6
Max acceleration force	F_{2B}	[N]	4724	1221	2352	2888
Max acceleration torque	T_{2B}	[Nm]	60	16	30	35
Precision			PR			PS
Feed force			High	Medium	Elevated	

Above values for rack and pinion take into consideration a number of load cycles: 1×10^6 for the rack; 1×10^7 for the pinion. Both in pulsating operation.

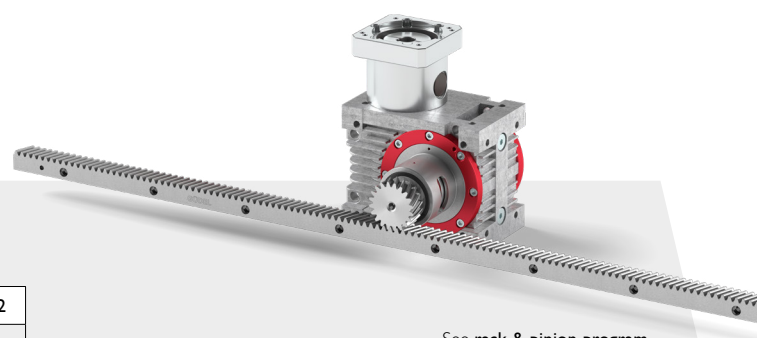

See **rack & pinion program** of your ideal drive train on pages 68 et seq.

See **flowcharts** to find your ideal drive train on pages 86 et seq.

Input

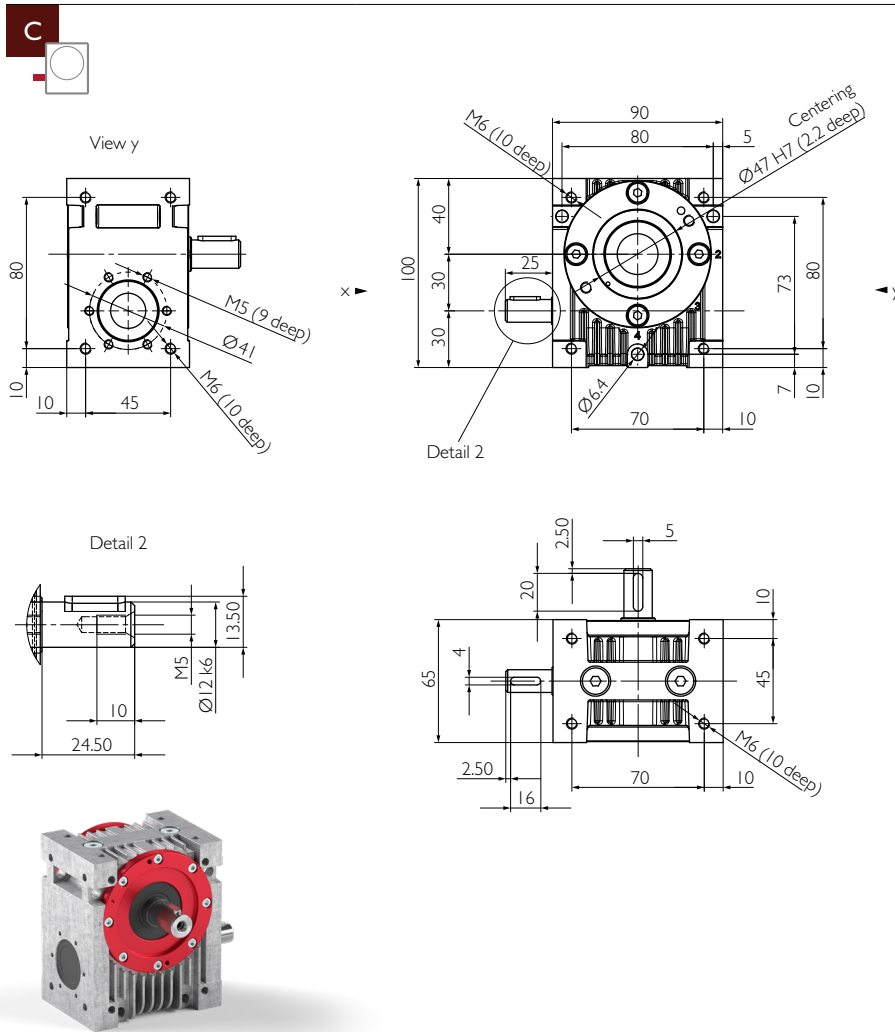

Example HPG 030 C4

C with option motor flange

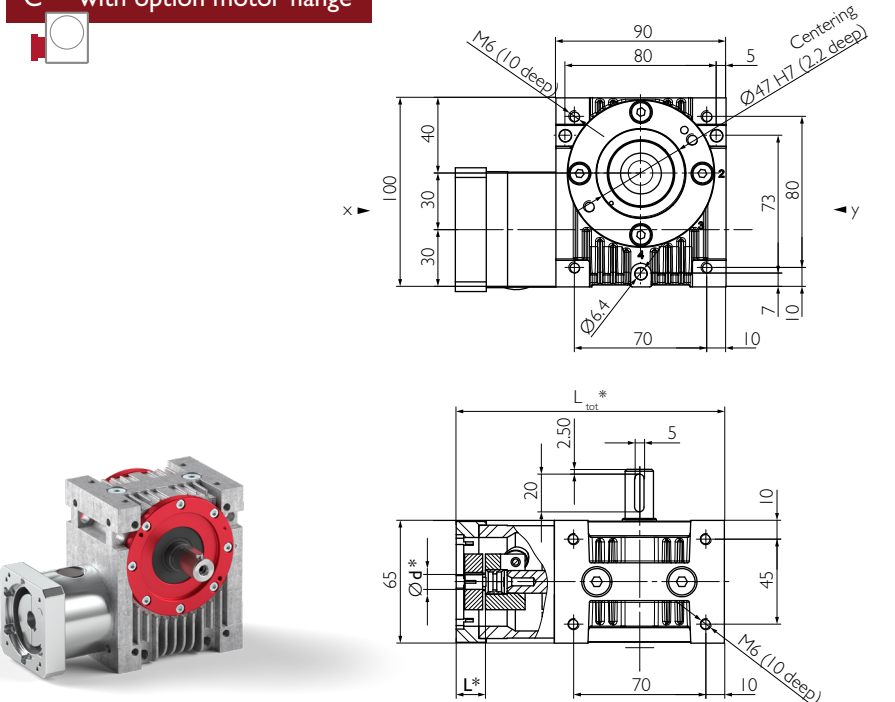

Example HPG 030 C6

* Motor-specific gearbox dimensions

Output

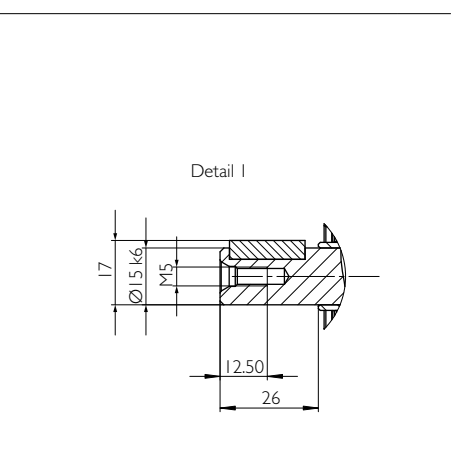
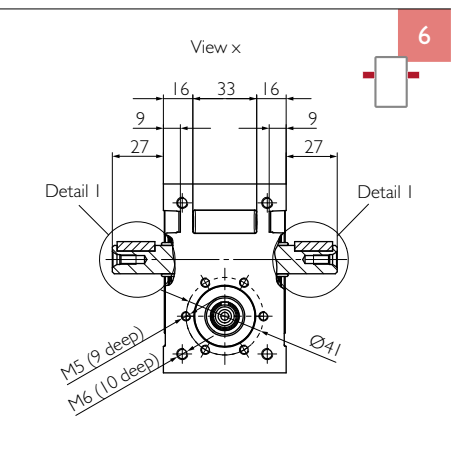
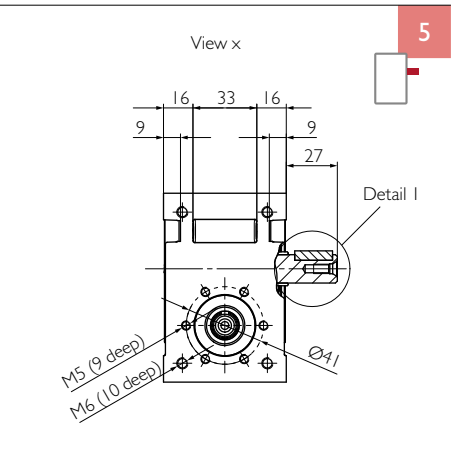
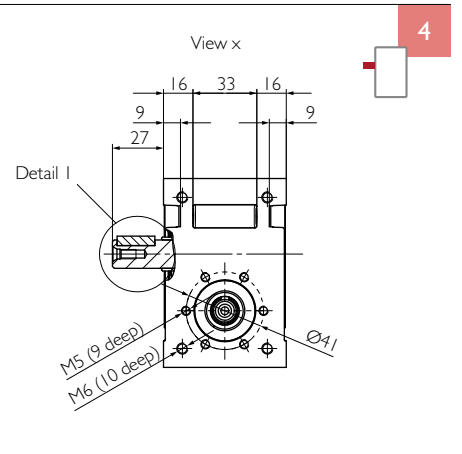

Ratio	i			2	3	4	5	6	8	10	13.33	16	24	30	47	60	
Nominal torque at the output Efficiency	$n_{1N} = 500$ rpm	T_{2N}	[Nm]	12.9	17.9	20.1	19.2	16.9	19.4	17.9	17.5	19.5	19.0	8.6	18.8	8.6	
		η	[%]	85	84	83	81	80	76	74	67	63	54	48	40	30	30
	$n_{1N} = 1000$ rpm	T_{2N}	[Nm]	11.3	16.0	18.3	17.5	15.5	17.9	16.6	16.2	18.1	17.6	8.6	17.5	8.6	
		η	[%]	86	86	85	83	81	77	74	68	65	55	50	44	40	
	$n_{1N} = 1500$ rpm	T_{2N}	[Nm]	10.0	14.4	16.7	16.2	14.3	16.6	15.4	15.1	16.9	16.4	8.6	16.3	8.6	
		η	[%]	86	86	85	83	80	77	73	68	64	54	49	45	40	
	$n_{1N} = 3000$ rpm	T_{2N}	[Nm]	7.4	11.2	13.3	13.1	11.7	13.7	12.8	12.6	14.0	13.7	8.6	13.6	8.6	
		η	[%]	84	84	83	81	77	74	71	67	62	53	48	44	40	
	$n_{1N} = 4500$ rpm	T_{2N}	[Nm]	5.9	9.2	11.0	11.0	9.9	11.6	10.9	10.8	12.0	11.8	10.0	11.7	10.0	
		η	[%]	81	82	81	78	76	73	69	65	60	51	47	42	37	
	$n_{1N} = 6000$ rpm	T_{2N}	[Nm]	4.9	7.8	9.4	9.4	8.6	10.1	9.5	9.4	10.5	10.3	10.0	10.2	10.0	
		η	[%]	79	79	78	77	75	72	68	62	56	47	42	37	33	
Max. acceleration torque		T_{2B}	[Nm]	13	21										10	21	10
Emergency stop torque		T_{2Not}	[Nm]	35										20	35	20	
Idling torque ^{a)}		T_{012}	[Nm]	0.65			0.6			0.5							
Max. input speed		n_{1Max}	[rpm]	6000													
Max. backlash ^{b)} at the output	PS	j_c	[arcmin]	<22	<18	<16	<16	<14	<12					<11			
Torsional rigidity from output to input		C_{t21}	[Nm/arcmin]	0.3	0.45	0.58	0.63	0.66	0.68	0.72	0.74	0.78	0.8	0.75	0.85	0.75	
Stability at the output		C_{2K}	[Nm/arcmin]	27													
Max. axial force ^{c) d)} at the output		F_{a2max}	[N]	910	1200	1500	1800	2200	2100	2300	2500	2700	2900	3100	2900	3100	
Max. radial force ^{c) e)} at the output		F_{r2max}	[N]	640	740	850	970	1100	980	1000	1000	1100	1200	1300	1300	1300	
Max. overturning torque ^{c)} at the output		M_{2max}	[Nm]	32	37	42	48	54	49	50	52	54	60	67	65	67	
Max. axial force ^{c) d)} at the input		F_{a1max}	[N]	890	740	700	780	890	820	890	910	860	880	1100	890	1100	
Max. radial force ^{c) f)} at the input		F_{r1max}	[N]	280	270	280	300	320	320	330	340	330	340	360	340	360	
Mass moment of inertia ^{g)}		J_1	[10 ⁻⁷ kg m ²]	230	110	68	49	38	28	23	19	18	16	15	15	15	
Mass moment of inertia ^{g) h)}		J_1	[10 ⁻⁷ kg m ²]	280	161	119	100	89	79	74	70	69	67	66	66	65	
Mass moment of inertia ^{g) i)}		J_1	[10 ⁻⁷ kg m ²]	510	390	348	329	318	308	303	299	298	296	295	295	295	
Service life		L_h	[h]	25000													
Weight without motor components		m	[kg]	1.7													
Weight with motor components		m	[kg]	≈ 2.2													
Max. permissible housing temperature			[°C]	+90													
Ambient temperature			[°C]	-15 up to +50													
Lubrication	synthetic gear oil (as per DIN 51502: CLP PG 460)																
Painting	None																
Protection class	IP65																

- a) approximate, at $n_1 = 3000$ rpm and operating temperature.
- b) Precision grade PS (standard backlash) for classic mechanical engineering applications.
- c) Bearing forces: Values valid at $n_1 = 3000$ rpm; $\frac{2}{3} T_{2N}$ and duty cycle of 40%. Consult with Güdel for composite bearing forces, axial and radial forces.
- c) d) in relation to shaft center.
- c) e) at a distance of 50 mm from the middle of the casing.
- c) f) at a distance of 60 mm from the middle of the casing.
- g) in relation to the input.
- g) h) including elastomer coupling 5103-14 (calculated with drilled hole for motor shaft-Ø15)
- g) i) including elastomer coupling 5103-19 (calculated with drilled hole for motor shaft-Ø15)

Bearing forces

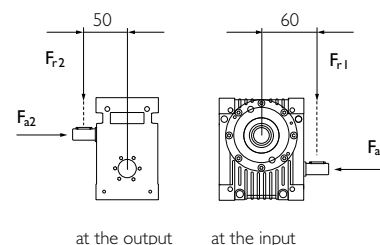

Input

Output

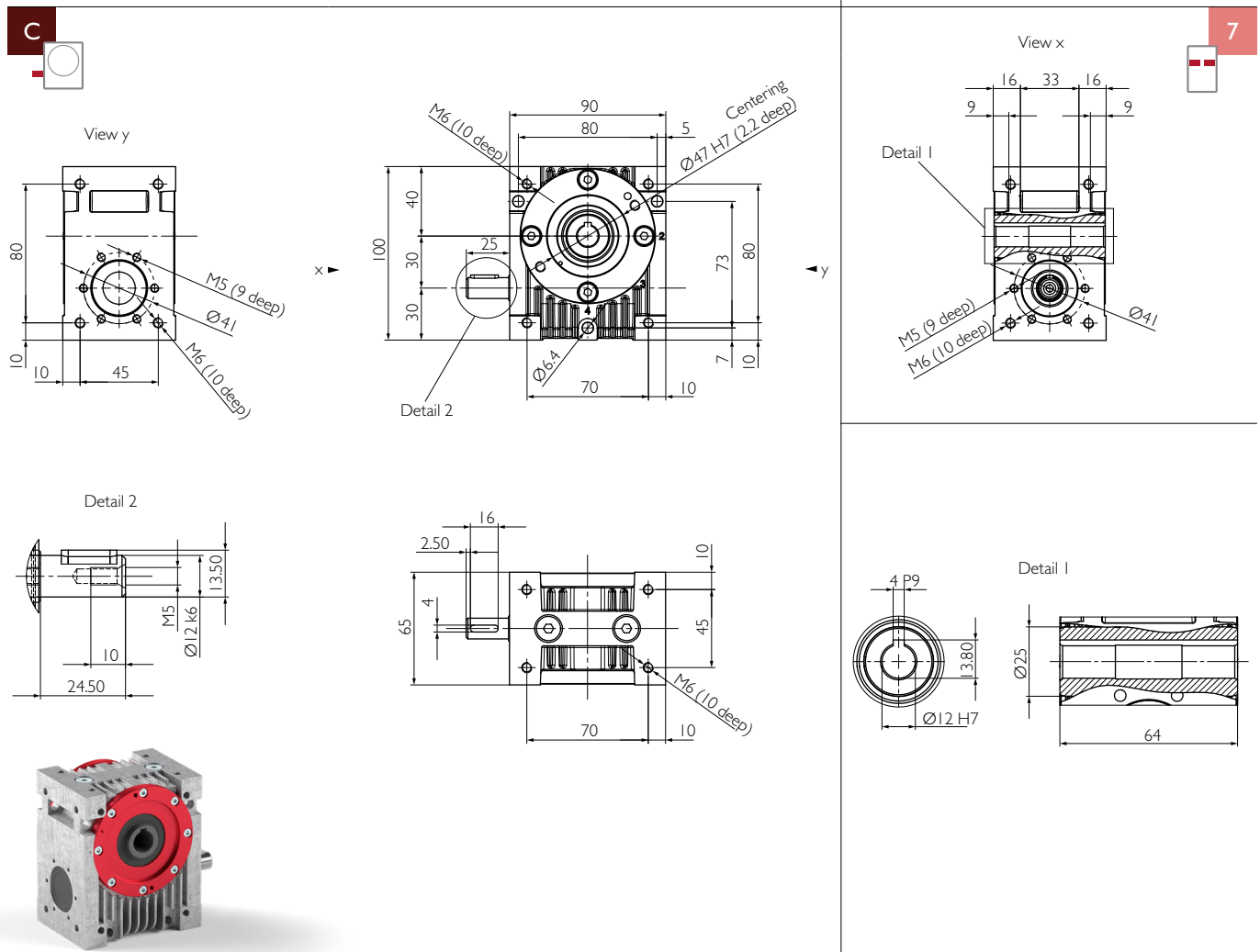

Example HPG 030 C7

C with option motor flange

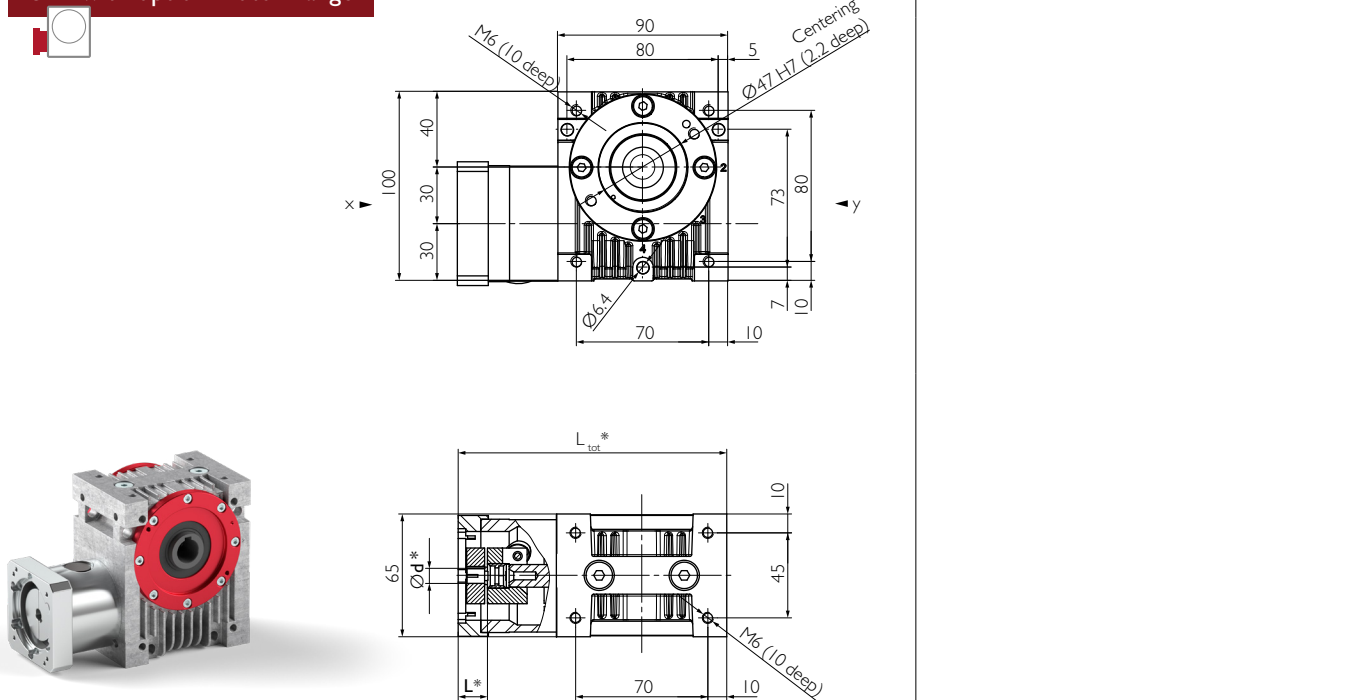

* Motor-specific gearbox dimensions

Ratio	i			2	3	4	5	6	8	10	13.33	16	24	30	47	60		
Nominal torque at the output Efficiency	$n_{1N} = 500$ rpm	T_{2N}	[Nm]	12.9	17.9	20.1	19.2	16.9	19.4	17.9	17.5	19.5	19.0	8.6	18.8	8.6		
		η	[%]	85	84	83	81	80	76	74	67	63	54	48	40	30	30	
	$n_{1N} = 1000$ rpm	T_{2N}	[Nm]	11.3	16.0	18.3	17.5	15.5	17.9	16.6	16.2	18.1	17.6	8.6	17.5	8.6		
		η	[%]	86	86	85	83	81	77	74	68	65	55	50	44	40		
	$n_{1N} = 1500$ rpm	T_{2N}	[Nm]	10.0	14.4	16.7	16.2	14.3	16.6	15.4	15.1	16.9	16.4	8.6	16.3	8.6		
		η	[%]	86	86	85	83	80	77	73	68	64	54	49	45	40		
	$n_{1N} = 3000$ rpm	T_{2N}	[Nm]	7.4	11.2	13.3	13.1	11.7	13.7	12.8	12.6	14.0	13.7	8.6	13.6	8.6		
		η	[%]	84	84	83	81	77	74	71	67	62	53	48	44	40		
	$n_{1N} = 4500$ rpm	T_{2N}	[Nm]	5.9	9.2	11.0	11.0	9.9	11.6	10.9	10.8	12.0	11.8	10.0	11.7	10.0		
		η	[%]	81	82	81	78	76	73	69	65	60	51	47	42	37		
	$n_{1N} = 6000$ rpm	T_{2N}	[Nm]	4.9	7.8	9.4	9.4	8.6	10.1	9.5	9.4	10.5	10.3	10.0	10.2	10.0		
		η	[%]	79	79	78	77	75	72	68	62	56	47	42	37	33		
Max. acceleration torque		T_{2B}	[Nm]	13	21										10	21	10	
Emergency stop torque		T_{2Not}	[Nm]	35										20	35	20		
Idling torque ^{a)}		T_{012}	[Nm]	0.65					0.6					0.5				
Max. input speed		n_{1Max}	[rpm]	6000														
Max. backlash ^{b)} at the output	PS	j_c	[arcmin]	<22	<18	<16	<16	<14	<12					<11				
Torsional rigidity from output to input		C_{t21}	[Nm/arcmin]	0.3	0.45	0.58	0.63	0.66	0.68	0.72	0.74	0.78	0.8	0.75	0.85	0.75		
Stability at the output		C_{2K}	[Nm/arcmin]	27														
Max. axial force ^{c) d)} at the output		F_{a2max}	[N]	560	770	1000	1300	1600	1600	1700	1900	2000	2400	2700	2600	2700		
Max. radial force ^{c) e)} at the output		F_{r2max}	[N]	510	570	660	770	860	800	810	850	880	990	1100	1100	1100		
Max. overturning torque ^{c)} at the output		M_{2max}	[Nm]	26	29	33	38	43	40	41	43	44	49	55	53	55		
Max. axial force ^{c) d)} at the input		F_{a1max}	[N]	890	740	700	780	890	820	890	910	860	880	1100	890	1100		
Max. radial force ^{c) f)} at the input		F_{r1max}	[N]	280	270	280	300	320	320	330	340	330	340	360	340	360		
Mass moment of inertia ^{g)}		J_1	[10 ⁻⁷ kg m ²]	138	69	45	34	28	22	19	17	16	15	15	15	15		
Mass moment of inertia ^{g) h)}		J_1	[10 ⁻⁷ kg m ²]	189	120	96	85	79	73	70	68	67	66	66	65	65		
Mass moment of inertia ^{g) i)}		J_1	[10 ⁻⁷ kg m ²]	418	349	325	314	308	302	299	297	296	295	295	295	295		
Service life		L_h	[h]	25000														
Weight without motor components		m	[kg]	1.6														
Weight with motor components		m	[kg]	≈ 2.2														
Max. permissible housing temperature			[°C]	+90														
Ambient temperature			[°C]	-15 up to +50														
Lubrication	synthetic gear oil (as per DIN 51502: CLP PG 460)																	
Painting	None																	
Protection class	IP65																	

- a) approximate, at $n_1 = 3000$ rpm and operating temperature.
- b) Precision grade PS (standard backlash) for classic mechanical engineering applications.
- c) Bearing forces: Values valid at $n_1 = 3000$ rpm; $\frac{2}{3} T_{2N}$ and duty cycle of 40%. Consult with Güdel for composite bearing forces, axial and radial forces.
- c) d) in relation to shaft center.
- c) e) at a distance of 50 mm from the middle of the casing.
- c) f) at a distance of 60 mm from the middle of the casing.
- g) in relation to the input.
- g) h) including elastomer coupling 5103-14 (calculated with drilled hole for motor shaft-Ø15)
- g) i) including elastomer coupling 5103-19 (calculated with drilled hole for motor shaft-Ø15)

Bearing forces

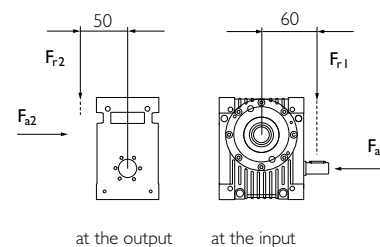

Input

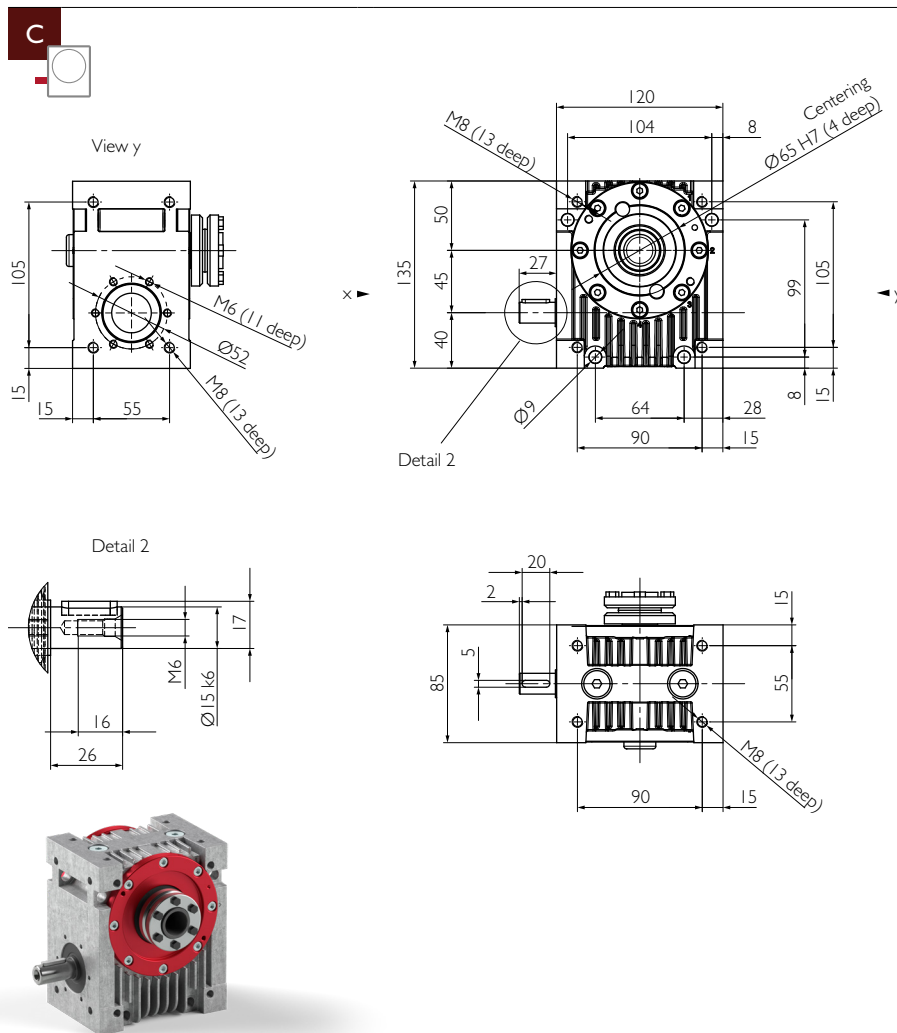

Example HPG 045 C2

C with option motor flange

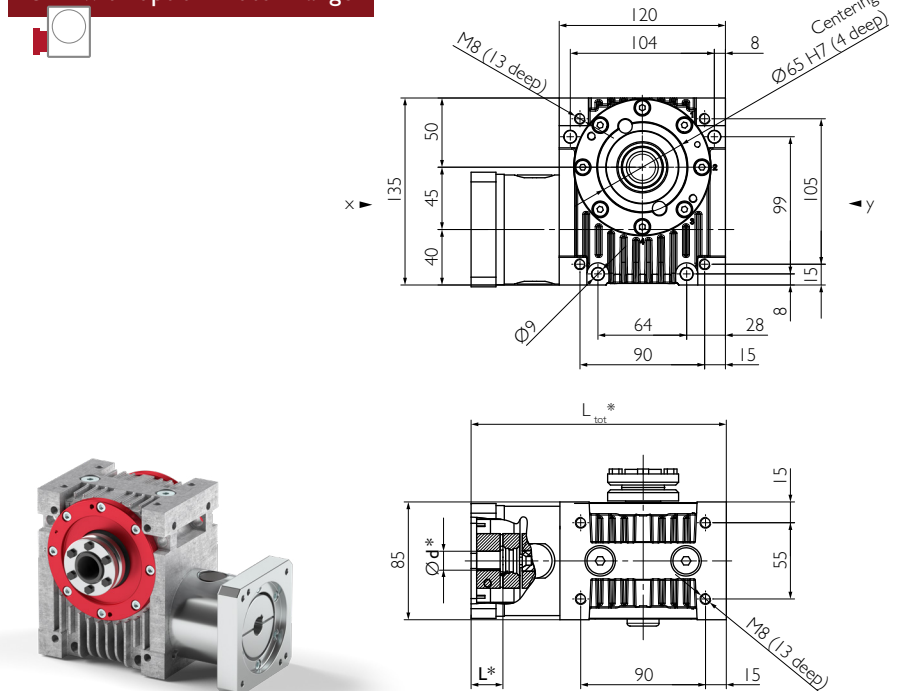

Example HPG 045 C1

* Motor-specific gearbox dimensions

Output

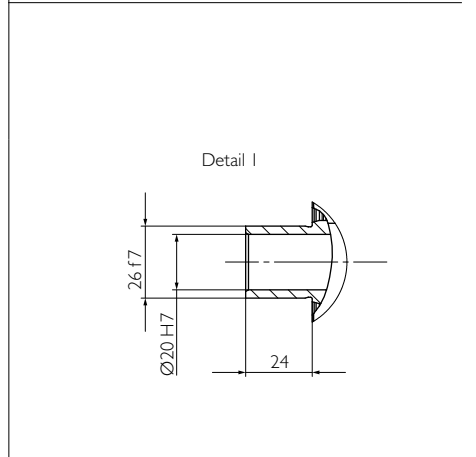
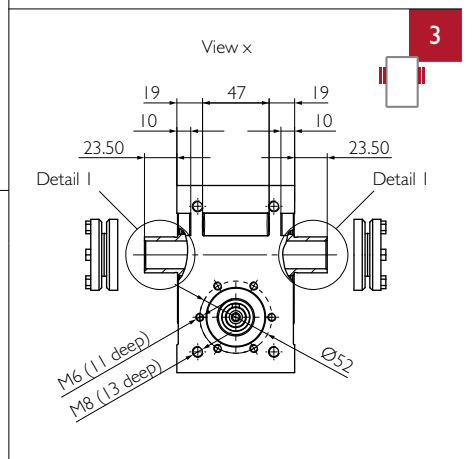
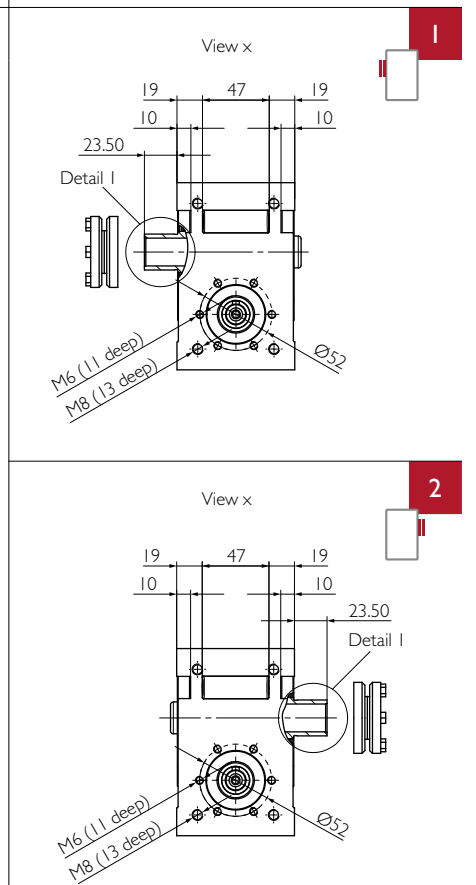

Ratio	i			2	3	4	5	6	8	10	13.33	16	24	30	47	60	
Nominal torque at the output Efficiency	n _{1N} = 500 rpm	T _{2N}	[Nm]	52.7	73.9	83.9	80.5	70.8	81.7	75.5	73.9	75.0	77.9	54.5	79.4	54.5	
		η	[%]	88	88	87	86	85	82	79	75	71	63	59	50	43	
	n _{1N} = 1000 rpm	T _{2N}	[Nm]	43.8	63.3	73.1	71.0	62.9	72.9	67.7	66.4	74.0	72.2	54.5	71.5	55.5	
		η	[%]	89	89	88	87	86	84	81	77	73	65	60	53	45	
	n _{1N} = 1500 rpm	T _{2N}	[Nm]	37.4	55.4	64.8	63.4	56.5	65.8	61.3	60.3	67.2	65.6	55.5	65.1	55.5	
		η	[%]	89	89	89	88	86	84	81	77	74	66	60	53	45	
	n _{1N} = 3000 rpm	T _{2N}	[Nm]	26.0	40.3	48.3	48.1	43.4	51.0	47.8	47.2	52.7	51.6	51.8	51.3	51.8	
		η	[%]	88	89	88	87	85	83	80	75	72	64	58	52	45	
	n _{1N} = 4500 rpm	T _{2N}	[Nm]	20.0	31.6	38.5	38.7	35.2	41.6	39.2	38.8	43.3	42.5	42.7	42.3	42.7	
		η	[%]	87	87	87	85	83	81	77	73	70	62	54	50	43	
	n _{1N} = 6000 rpm	T _{2N}	[Nm]	16.2	26.0	32.0	32.4	29.6	35.2	33.2	33.0	36.8	36.1	36.4	36.0	36.4	
		η	[%]	85	86	85	84	81	79	75	70	66	58	51	46	40	
Max. acceleration torque		T _{2B}	[Nm]	60	90										60	90	60
Emergency stop torque		T _{2Not}	[Nm]	120										80	120	80	
Idling torque ^{a)}		T ₀₁₂	[Nm]	1.05			0.95			0.8							
Max. input speed		n _{1Max}	[rpm]	6000													
Max. backlash ^{b)} at the output	PS	j _c	[arcmin]	<15	<12	<11	<11	<9	<8						<7		
	PR	j _c	[arcmin]	<10	<8	<7	<7	<6	<5.5						<5		
Torsional rigidity from output to input		C _{t21}	[Nm/arcmin]	1.6	2.8	3.6	4	4.3	4.5	4.9	5.3	5.5	5.8	5.5	6	5.5	
Stability at the output		C _{2K}	[Nm/arcmin]	30													
Max. axial force ^{c) d)} at the output		F _{a2max}	[N]	720	1000	1600	2200	2800	2900	3300	3700	3900	4700	4700	4800	4800	
Max. radial force ^{c) e)} at the output		F _{r2max}	[N]	700	820	1200	1400	1600	1600	1600	1700	1800	2000	2100	2200	2200	
Max. overturning torque ^{c)} at the output		M _{2max}	[Nm]	45	53	76	91	110	100	110	110	110	130	140	140	140	
Max. axial force ^{c) d)} at the input		F _{a1max}	[N]	1400	980	860	1000	1300	1100	1300	1300	1200	1200	1200	1200	1200	
Max. radial force ^{c) f)} at the input		F _{r1max}	[N]	510	470	430	510	590	550	610	630	580	610	600	620	600	
Mass moment of inertia ^{g)}		J _I	[10 ⁻⁶ kg m ²]	120	57	34	24	19	13	10	9	8	7	6	6	6	
Mass moment of inertia ^{g) h)}		J _I	[10 ⁻⁶ kg m ²]	148	85	62	52	47	41	38	37	36	35	34	34	34	
Mass moment of inertia ^{g) i)}		J _I	[10 ⁻⁶ kg m ²]	235	172	149	139	134	128	125	124	123	122	121	121	121	
Service life		L _h	[h]	25000													
Weight without motor components		m	[kg]	4													
Weight with motor components		m	[kg]	≈ 5													
Max. permissible housing temperature			[°C]	+90													
Ambient temperature			[°C]	-15 up to +50													
Lubrication	synthetic gear oil (as per DIN 51502: CLP PG 460)																
Painting	None																
Protection class	IP65																

- a) approximate, at n₁ = 3000 rpm and operating temperature.
- b) Precision grade PS (standard backlash) for classic mechanical engineering applications.
Precision grade PR (reduced backlash) for precise process applications.
- c) Bearing forces: Values valid at n₁ = 3000 rpm; ½ T_{2N} and duty cycle of 40%. Consult with Güdel for composite bearing forces, axial and radial forces.
- c) d) in relation to shaft center.
- c) e) at a distance of 65 mm from the middle of the casing.
- c) f) at a distance of 75 mm from the middle of the casing.
- g) in relation to the input, including shrink disc at the output (output 1 & 2), with two shrink discs (output 3) increase values by 90/ i₂.
- g) h) including elastomer coupling 5103-19 (calculated with drilled hole for motor shaft-Ø15)
- g) i) including elastomer coupling 5103-24 (calculated with drilled hole for motor shaft-Ø20)

Bearing forces

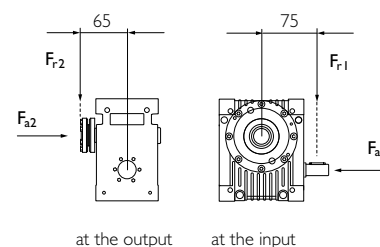

Package

		Output flange including bearing & pinion					
Radial rigidity	C ₃	[N/mm]	23000				
Speed	n _{2N}	[rpm]	1500	750	400	150	100
Max. radial force ^{j)}	F _{rmax}	[N]	1900	2400	2900	3200	3500

j) Bearing forces: Values valid at duty cycle of 40% at a distance of 15 mm from the end of the bearing.

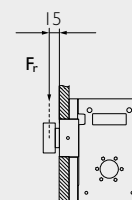

Detailed information about the package, options & accessories on pages 36 and 37.

Output flange including bearing & pinion a)

Package

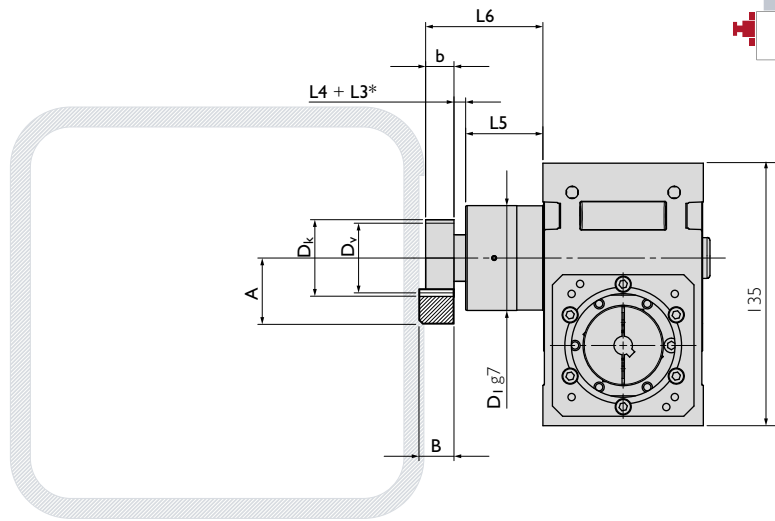
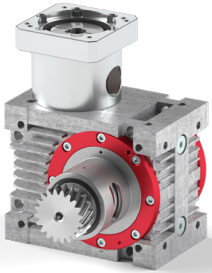

Example HPG 045 C2 Package

Package

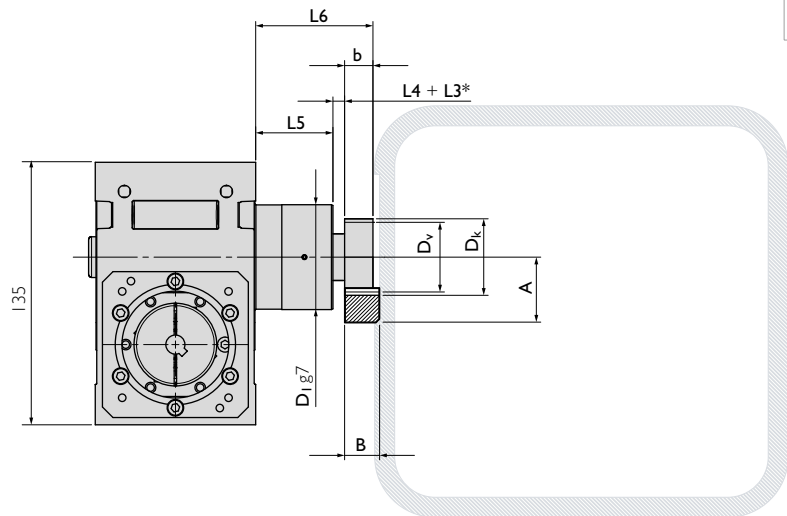

a) The output flange must be supported by the customer supplied equipment at the bearing end (D1), in a hole with an H8 tolerance.

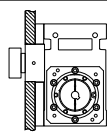

* L3 for additional distance ring.

Geometric information

Helical modular pitch	Part. No.	m_n	P_t	z	A	b	B	D_k	D_0	D_v	D_1	L4	L5	L6
Pinion 1	211120	1.5	5.00	20	33.415	20	19	34.83	31.831	31.830	60	4.5	43	67.5
													53	77.5
Pinion 2	211216	2	6.66	16	39.575	20	24	39.15	33.953	35.153	60	8.0	43	71.0
													53	81.0

m_n : Normal module, P_t : Transverse pitch [mm], z : Number of teeth, D_v : Pitch circle diameter for design, D_0 : Pitch circle diameter for calculation

Straight modular pitch	Part. No.	m_n	P_n	z	A	b	B	D_k	D_0	D_v	D_1	L4	L5	L6
Pinion 3	201120	1.5	4.72	20	32.500	20	19	33.00	30.000	30.000	60	4.5	43	67.5
													53	77.5
Pinion 4	201216	2	6.28	16	38.600	20	24	37.20	32.000	33.200	60	8.0	43	71.0
													53	81.0

m_n : Normal module, P_n : Normal pitch [mm], z : Number of teeth, D_v : Pitch circle diameter for design, D_0 : Pitch circle diameter for calculation

Spacer elements

With pinion special solutions on request

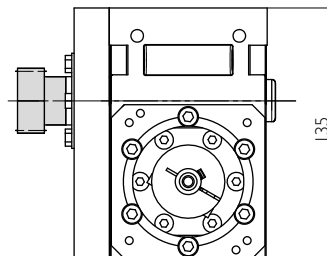
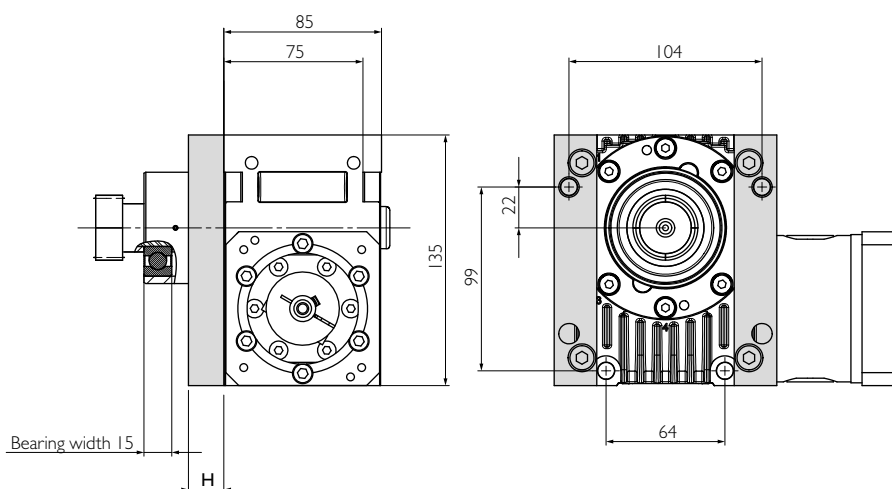

Casing can only be fastened with long screws as per the bore hole pattern.
Screws M6 of length 56mm + H + thread depth, tightening torque 9Nm.

Shrink disc

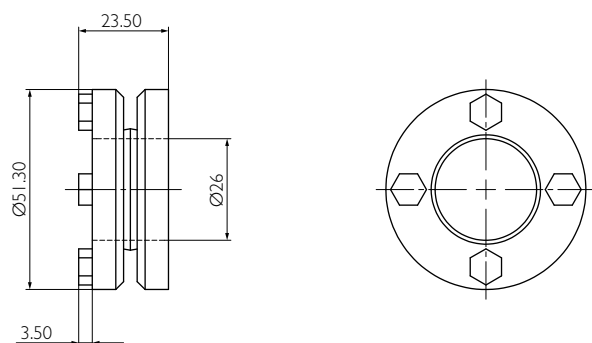

Elastomer coupling

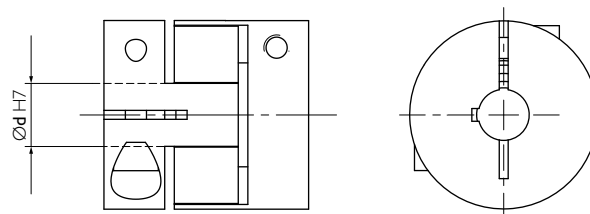

For more details see **Motor Interface** on page 84 et. seq.

Your ideal drive train

Our function package with high-performance angle gearbox, output flange, pinion and rack by Güdel.

			Pinion 1			Pinion 2			Pinion 3	Pinion 4	
			Q6	Q7	Q9	Q6	Q7	Q9	Q6	Q6	
Max acceleration force	F _{2B}	[N]	5004	1654	2510	7075	1760	4752	3638	4810	
Max acceleration torque	T _{2B}	[Nm]	80	26	40	120	30	81	55	77	
Precision			PR			PS			PR		PS
Feed force			High	Medium	Elevated	High	Medium	Elevated			

Above values for rack and pinion take into consideration a number of load cycles: 1x10⁶ for the rack; 1x10⁷ for the pinion. Both in pulsating operation.

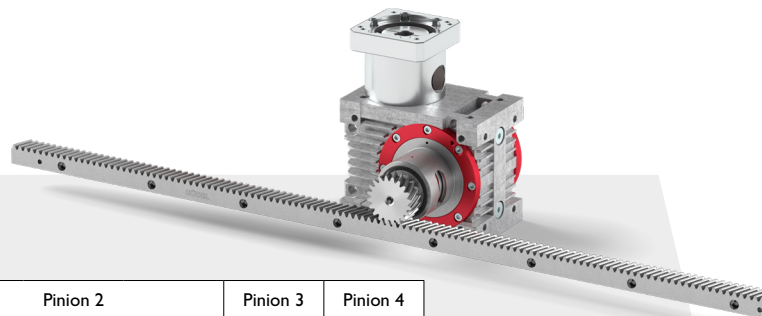

See **rack & pinion program** of your ideal drive train on pages 68 et seq.

See **flowcharts** to find your ideal drive train on pages 86 et seq.

Ratio	i			2	3	4	5	6	8	10	13.33	16	24	30	47	60	
Nominal torque at the output Efficiency	$n_{1N} = 500$ rpm	T_{2N}	[Nm]	52.7	73.9	83.9	80.5	70.8	81.7	75.5	73.9	75.0	77.9	54.5	79.4	54.5	
		η	[%]	88	88	87	86	85	82	79	75	71	63	59	50	43	
	$n_{1N} = 1000$ rpm	T_{2N}	[Nm]	43.8	63.3	73.1	71.0	62.9	72.9	67.7	66.4	74.0	72.2	54.5	71.5	55.5	
		η	[%]	89	89	88	87	86	84	81	77	73	65	60	53	45	
	$n_{1N} = 1500$ rpm	T_{2N}	[Nm]	37.4	55.4	64.8	63.4	56.5	65.8	61.3	60.3	67.2	65.6	55.5	65.1	55.5	
		η	[%]	89	89	89	88	86	84	81	77	74	66	60	53	45	
	$n_{1N} = 3000$ rpm	T_{2N}	[Nm]	26.0	40.3	48.3	48.1	43.4	51.0	47.8	47.2	52.7	51.6	51.8	51.3	51.8	
		η	[%]	88	89	88	87	85	83	80	75	72	64	58	52	45	
	$n_{1N} = 4500$ rpm	T_{2N}	[Nm]	20.0	31.6	38.5	38.7	35.2	41.6	39.2	38.8	43.3	42.5	42.7	42.3	42.7	
		η	[%]	87	87	87	85	83	81	77	73	70	62	54	50	43	
	$n_{1N} = 6000$ rpm	T_{2N}	[Nm]	16.2	26.0	32.0	32.4	29.6	35.2	33.2	33.0	36.8	36.1	36.4	36.0	36.4	
		η	[%]	85	86	85	84	81	79	75	70	66	58	51	46	40	
Max. acceleration torque		T_{2B}	[Nm]	60	90										60	90	60
Emergency stop torque		T_{2Not}	[Nm]	120										80	120	80	
Idling torque ^{a)}		T_{012}	[Nm]	1.05			0.95			0.8							
Max. input speed		n_{1Max}	[rpm]	6000													
Max. backlash ^{b)} at the output	PS	j_c	[arcmin]	<15	<12	<11	<11	<9	<8						<7		
	PR	j_c	[arcmin]	<10	<8	<7	<7	<6	<5.5						<5		
Torsional rigidity from output to input		C_{t21}	[Nm/arcmin]	1.6	2.8	3.6	4	4.3	4.5	4.9	5.3	5.5	5.8	5.5	6	5.5	
Stability at the output		C_{2K}	[Nm/arcmin]	30													
Max. axial force ^{c) d)} at the output		F_{a2max}	[N]	720	1000	1600	2200	2800	2900	3300	3700	3900	4700	4700	4800	4800	
Max. radial force ^{c) e)} at the output		F_{r2max}	[N]	700	820	1200	1400	1600	1600	1600	1700	1800	2000	2100	2200	2200	
Max. overturning torque ^{c)} at the output		M_{2max}	[Nm]	45	53	76	91	110	100	110	110	110	130	140	140	140	
Max. axial force ^{c) d)} at the input		F_{a1max}	[N]	1400	980	860	1000	1300	1100	1300	1300	1200	1200	1200	1200	1200	
Max. radial force ^{c) f)} at the input		F_{r1max}	[N]	510	470	430	510	590	550	610	630	580	610	600	620	600	
Mass moment of inertia ^{g)}		J_I	[10 ⁻⁶ kg m ²]	120	57	34	24	19	13	10	9	8	7	6	6	6	
Mass moment of inertia ^{g) h)}		J_I	[10 ⁻⁶ kg m ²]	148	85	62	52	47	41	38	37	36	35	34	34	34	
Mass moment of inertia ^{g) i)}		J_I	[10 ⁻⁶ kg m ²]	235	172	149	139	134	128	125	124	123	122	121	121	121	
Service life		L_h	[h]	25000													
Weight without motor components		m	[kg]	4													
Weight with motor components		m	[kg]	≈ 5													
Max. permissible housing temperature			[°C]	+90													
Ambient temperature			[°C]	-15 up to +50													
Lubrication	synthetic gear oil (as per DIN 51502: CLP PG 460)																
Painting	None																
Protection class	IP65																

- a) approximate, at $n_1 = 3000$ rpm and operating temperature.
- b) Precision grade PS (standard backlash) for classic mechanical engineering applications.
Precision grade PR (reduced backlash) for precise process applications.
- c) Bearing forces: Values valid at $n_1 = 3000$ rpm; $\frac{2}{3} T_{2N}$ and duty cycle of 40%.
Consult with Güdel for composite bearing forces, axial and radial forces.
- c) d) in relation to shaft center.
- c) e) at a distance of 65 mm from the middle of the casing.
- c) f) at a distance of 75 mm from the middle of the casing.
- g) in relation to the input.
- g) h) including elastomer coupling 5103-19 (calculated with drilled hole for motor shaft-Ø15)
- g) i) including elastomer coupling 5103-24 (calculated with drilled hole for motor shaft-Ø20)

Bearing forces

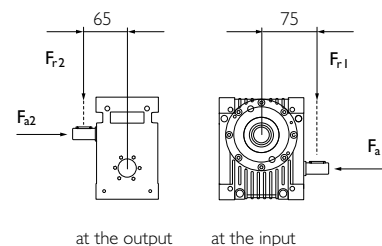

Input

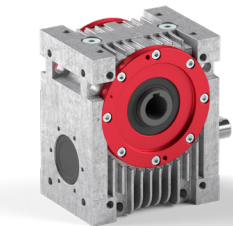
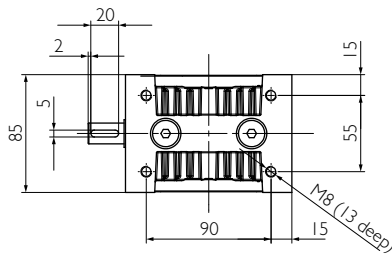
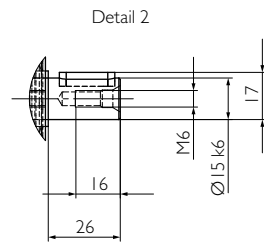
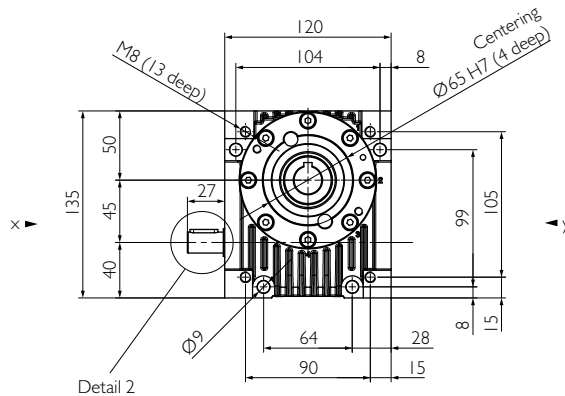
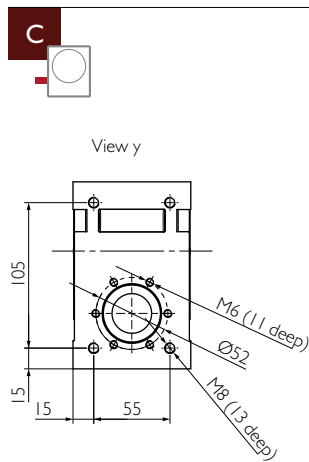

Example HPG 045 C7

Output

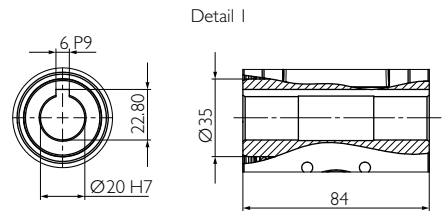
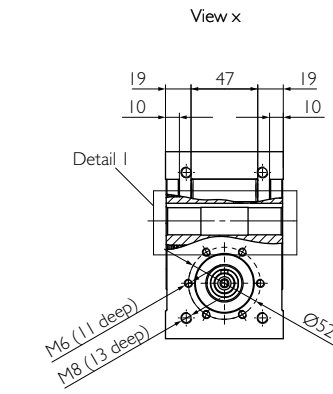

C with option motor flange

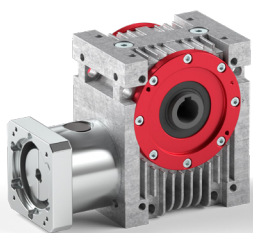
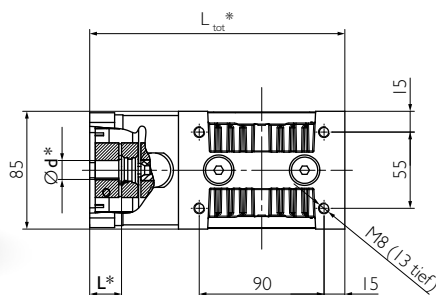
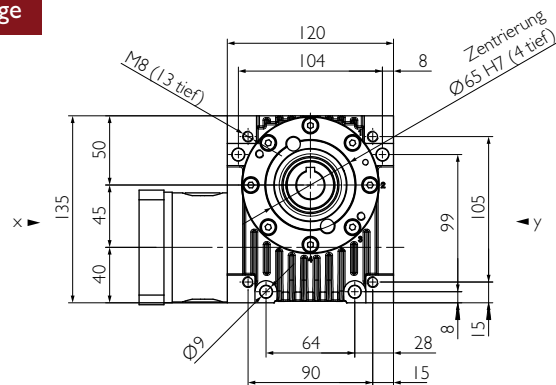

Example HPG 045 C7

* Motor-specific gearbox dimensions

Ratio	i			2	3	4	5	6	8	10	13.33	16	24	30	47	60	
Nominal torque at the output Efficiency	$n_{1N} = 500$ rpm	T_{2N}	[Nm]	52.7	73.9	83.9	80.5	70.8	81.7	75.5	73.9	75.0	77.9	54.5	79.4	54.5	
		η	[%]	88	88	87	86	85	82	79	75	71	63	59	50	43	
	$n_{1N} = 1000$ rpm	T_{2N}	[Nm]	43.8	63.3	73.1	71.0	62.9	72.9	67.7	66.4	74.0	72.2	54.5	71.5	55.5	
		η	[%]	89	89	88	87	86	84	81	77	73	65	60	53	45	
	$n_{1N} = 1500$ rpm	T_{2N}	[Nm]	37.4	55.4	64.8	63.4	56.5	65.8	61.3	60.3	67.2	65.6	55.5	65.1	55.5	
		η	[%]	89	89	89	88	86	84	81	77	74	66	60	53	45	
	$n_{1N} = 3000$ rpm	T_{2N}	[Nm]	26.0	40.3	48.3	48.1	43.4	51.0	47.8	47.2	52.7	51.6	51.8	51.3	51.8	
		η	[%]	88	89	88	87	85	83	80	75	72	64	58	52	45	
	$n_{1N} = 4500$ rpm	T_{2N}	[Nm]	20.0	31.6	38.5	38.7	35.2	41.6	39.2	38.8	43.3	42.5	42.7	42.3	42.7	
		η	[%]	87	87	87	85	83	81	77	73	70	62	54	50	43	
	$n_{1N} = 6000$ rpm	T_{2N}	[Nm]	16.2	26.0	32.0	32.4	29.6	35.2	33.2	33.0	36.8	36.1	36.4	36.0	36.4	
		η	[%]	85	86	85	84	81	79	75	70	66	58	51	46	40	
Max. acceleration torque		T_{2B}	[Nm]	60	90										60	90	60
Emergency stop torque		T_{2Not}	[Nm]	120										80	120	80	
Idling torque ^{a)}		T_{012}	[Nm]	1.05			0.95			0.8							
Max. input speed		n_{1Max}	[rpm]	6000													
Max. backlash ^{b)} at the output	PS	j_c	[arcmin]	<15	<12	<11	<11	<9	<8						<7		
	PR	j_c	[arcmin]	<10	<8	<7	<7	<6	<5.5						<5		
Torsional rigidity from output to input		C_{t21}	[Nm/arcmin]	1.6	2.8	3.6	4	4.3	4.5	4.9	5.3	5.5	5.8	5.5	6	5.5	
Stability at the output		C_{2K}	[Nm/arcmin]	30													
Max. axial force ^{c) d)} at the output		F_{a2max}	[N]	360	600	1100	1600	2200	2400	2700	3100	3200	4000	4300	4400	4400	
Max. radial force ^{c) e)} at the output		F_{r2max}	[N]	370	580	780	1200	1400	1400	1400	1500	1500	1700	1900	1900	1900	
Max. overturning torque ^{c)} at the output		M_{2max}	[Nm]	24	38	51	75	89	88	91	96	98	110	120	120	120	
Max. axial force ^{c) d)} at the input		F_{a1max}	[N]	1400	980	860	1000	1300	1100	1300	1300	1200	1200	1200	1200	1200	
Max. radial force ^{c) f)} at the input		F_{r1max}	[N]	510	470	430	510	590	550	610	630	580	610	600	620	600	
Mass moment of inertia ^{g)}		J_1	[10 ⁻⁶ kg m ²]	97	47	29	21	16	12	10	8	7	7	6	6	6	
Mass moment of inertia ^{g) h)}		J_1	[10 ⁻⁶ kg m ²]	125	75	57	49	44	40	38	36	35	35	34	34	34	
Mass moment of inertia ^{g) i)}		J_1	[10 ⁻⁶ kg m ²]	212	162	144	136	131	127	125	123	122	122	121	121	121	
Service life		L_h	[h]	25000													
Weight without motor components		m	[kg]	4													
Weight with motor components		m	[kg]	≈ 5													
Max. permissible housing temperature			[°C]	+90													
Ambient temperature			[°C]	-15 up to +50													
Lubrication	synthetic gear oil (as per DIN 51502: CLP PG 460)																
Painting	None																
Protection class	IP65																

- a) approximate, at $n_1 = 3000$ rpm and operating temperature.
- b) Precision grade PS (standard backlash) for classic mechanical engineering applications.
Precision grade PR (reduced backlash) for precise process applications.
- c) Bearing forces: Values valid at $n_1 = 3000$ rpm; $\frac{2}{3} T_{2N}$ and duty cycle of 40%.
Consult with Güdel for composite bearing forces, axial and radial forces.
- c) d) in relation to shaft center.
- c) e) at a distance of 65 mm from the middle of the casing.
- c) f) at a distance of 75 mm from the middle of the casing.
- g) in relation to the input.
- g) h) including elastomer coupling 5103-19 (calculated with drilled hole for motor shaft-Ø15)
- g) i) including elastomer coupling 5103-24 (calculated with drilled hole for motor shaft-Ø20)

Bearing forces

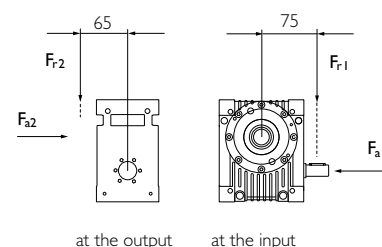

Input

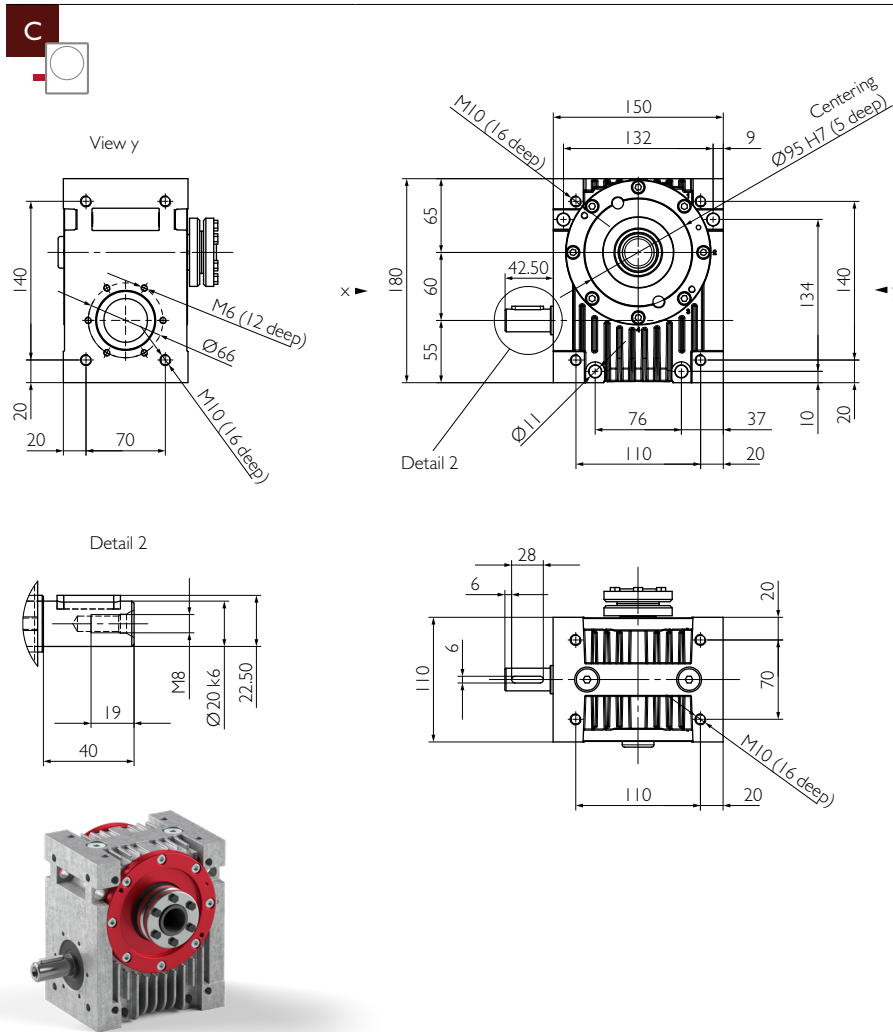

Example HPG 060 C2

C with option motor flange

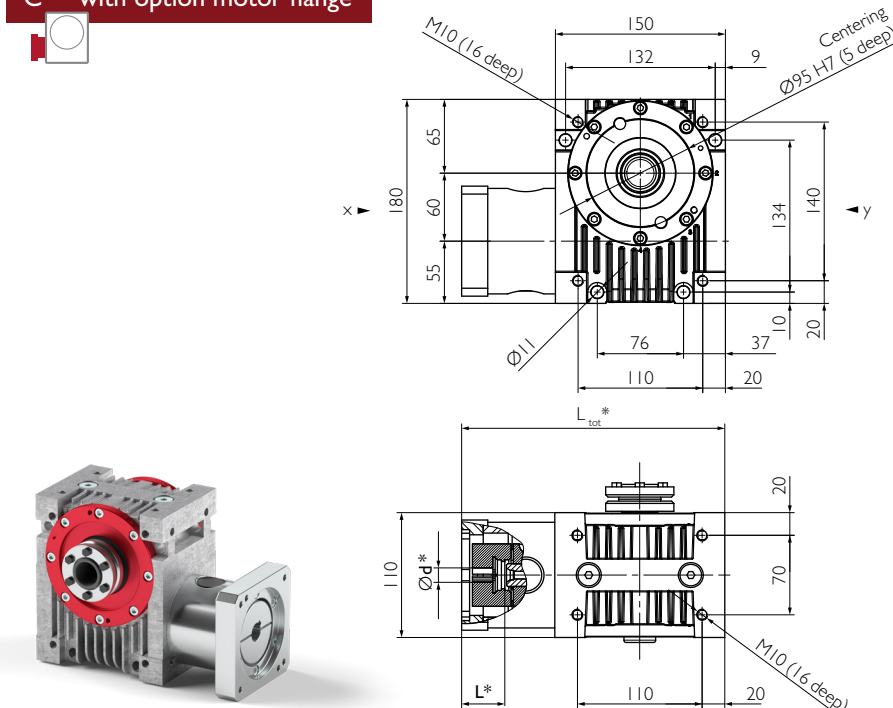

Example HPG 060 C3

* Motor-specific gearbox dimensions

Output

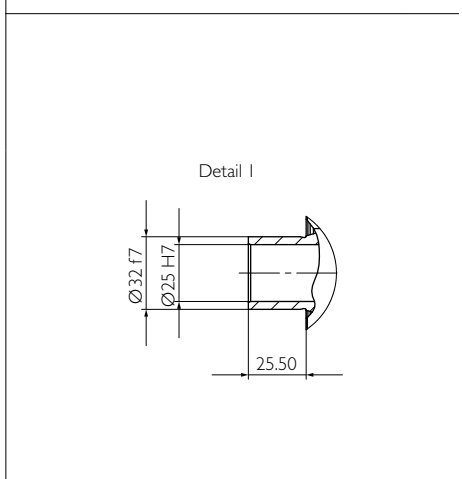
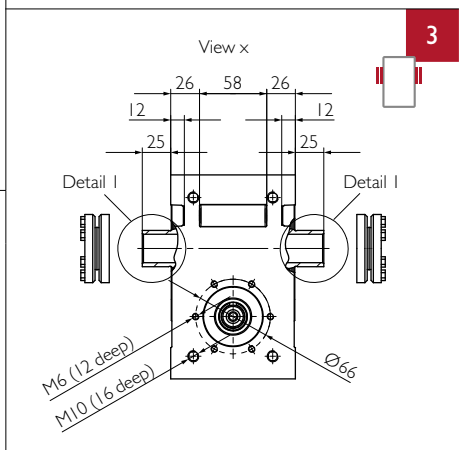
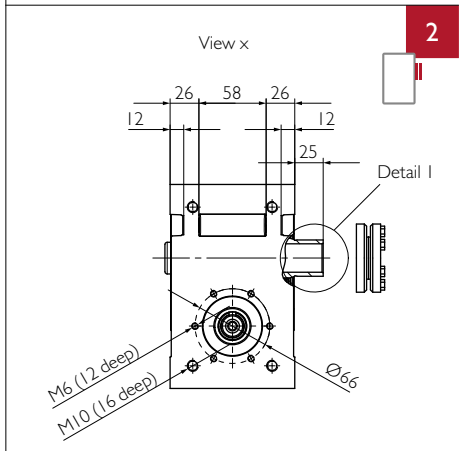
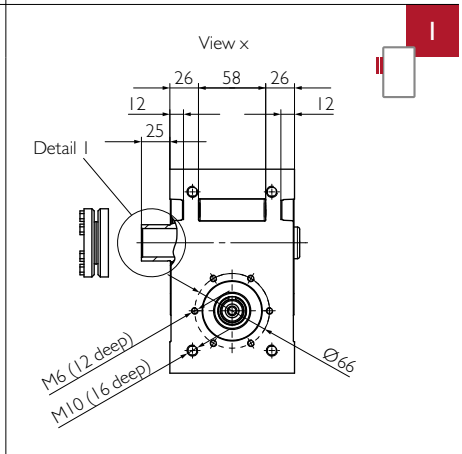

Ratio	i			2	3	4	5	6	8	10	13.33	16	24	30	47	60	
Nominal torque at the output Efficiency	n _{1N} = 500 rpm	T _{2N}	[Nm]	135	192	219	211	186	215	199	195	195	202	144	209	144	
		η	[%]	89	89	88	88	87	84	82	78	74	67	64	54	50	
	n _{1N} = 1000 rpm	T _{2N}	[Nm]	107	158	184	180	160	186	173	170	190	185	144	184	144	
		η	[%]	90	90	90	89	88	86	84	81	77	70	65	56	53	
	n _{1N} = 1500 rpm	T _{2N}	[Nm]	89	135	159	157	140	164	153	151	168	165	144	163	144	
		η	[%]	90	91	90	89	89	86	84	81	78	70	65	56	52	
	n _{1N} = 3000 rpm	T _{2N}	[Nm]	59	93	113	113	103	121	114	113	126	124	126	123	126	
		η	[%]	90	90	90	89	88	86	83	80	77	69	64	55	50	
	n _{1N} = 4500 rpm	T _{2N}	[Nm]	44	71	88	89	81	96	91	90	101	99	101	98	101	
		η	[%]	89	89	89	88	87	84	82	78	75	67	61	52	47	
	n _{1N} = 6000 rpm	T _{2N}	[Nm]	35	58	71	73	67	80	75	75	84	82	84	82	84	
		η	[%]	88	88	88	87	85	83	80	75	72	64	58	48	44	
Max. acceleration torque		T _{2B}	[Nm]	140	220										150	220	150
Emergency stop torque		T _{2Not}	[Nm]	300										200	300	200	
Idling torque ^{a)}		T ₀₁₂	[Nm]	1.45			1.3			1.1							
Max. input speed		n _{1Max}	[rpm]	6000													
Max. backlash ^{b)} at the output	PS	j _c	[arcmin]	<13	<10	<9	<9	<8	<7						<6		
	PR	j _c	[arcmin]	<9	<7	<6	<6	<5	<4.5						<4		
Torsional rigidity from output to input		C _{t21}	[Nm/arcmin]	2.5	4.8	7.6	8.6	10	11	12.1	13.3	14.5	15.4	15	16	15	
Stability at the output		C _{2K}	[Nm/arcmin]	42													
Max. axial force ^{c)d)} at the output		F _{a2max}	[N]	1300	1700	2600	3600	4400	4100	4500	5100	5300	6500	7300	7500	7500	
Max. radial force ^{c)e)} at the output		F _{r2max}	[N]	1300	1500	2100	2500	2800	2400	2500	2600	2700	3100	3300	3300	3300	
Max. overturning torque ^{c)} at the output		M _{2max}	[Nm]	110	120	170	200	220	190	200	210	220	250	270	270	270	
Max. axial force ^{c)d)} at the input		F _{a1max}	[N]	1700	990	750	1000	1400	1100	1400	1600	1200	1400	1300	1500	1300	
Max. radial force ^{c)f)} at the input		F _{r1max}	[N]	690	510	390	520	720	560	710	760	610	650	620	690	630	
Mass moment of inertia ^{g)}		J _I	[10 ⁻⁶ kg m ²]	467	221	135	95	74	52	42	34	31	27	26	25	25	
Mass moment of inertia ^{g)h)}		J _I	[10 ⁻⁶ kg m ²]	582	336	250	210	189	167	157	149	146	142	141	140	140	
Mass moment of inertia ^{g)i)}		J _I	[10 ⁻⁶ kg m ²]	721	475	389	349	328	306	296	288	285	281	280	279	279	
Service life		L _h	[h]	25000													
Weight without motor components		m	[kg]	9													
Weight with motor components		m	[kg]	≈ 11													
Max. permissible housing temperature			[°C]	+90													
Ambient temperature			[°C]	-15 up to +50													
Lubrication				synthetic gear oil (as per DIN 51502: CLP PG 460)													
Painting				None													
Protection class				IP65													

- a) approximate, at n₁ = 3000 rpm and operating temperature.
- b) Precision grade PS (standard backlash) for classic mechanical engineering applications.
Precision grade PR (reduced backlash) for precise process applications.
- c) Bearing forces: Values valid at n₁ = 3000 rpm; 2/3 T_{2N} and duty cycle of 40%. Consult with Güdel for composite bearing forces, axial and radial forces.
- c) d) in relation to shaft center.
- c) e) at a distance of 80 mm from the middle of the casing.
- c) f) at a distance of 95 mm from the middle of the casing.
- g) in relation to the input, including shrink disc at the output (output 1 & 2), with two shrink discs (output 3) increase values by 200/i².
- g) h) including elastomer coupling 5103-24 (calculated with drilled hole for motor shaft-Ø20)
- g) i) including elastomer coupling 5103-28 (calculated with drilled hole for motor shaft-Ø25)

Bearing forces

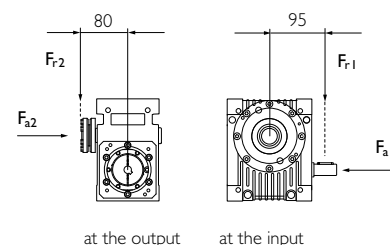

Package

		Output flange including bearing & pinion					
Radial rigidity	C ₃	[N/mm]	24000				
Speed	n _{2N}	[rpm]	1500	750	400	150	100
Max. radial force ^{j)}	F _{rmax}	[N]	2500	3200	4000	4500	5000

j) Bearing forces: Values valid at duty cycle of 40% at a distance of 15mm from the end of the bearing.

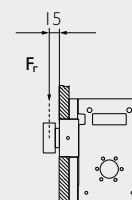

Detailed information about the package, options & accessories on pages 44 and 45.

Output flange including bearing & pinion a)

Package

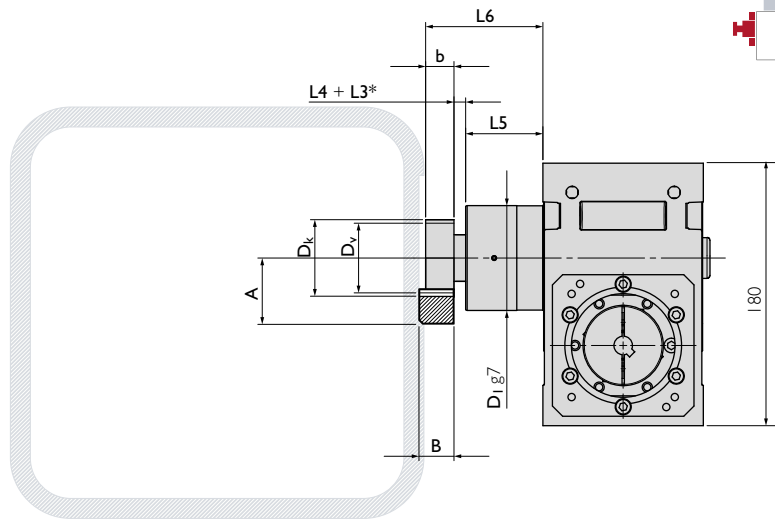
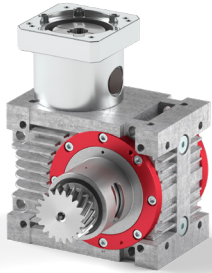

Example HPG 060 C2 Package

Package

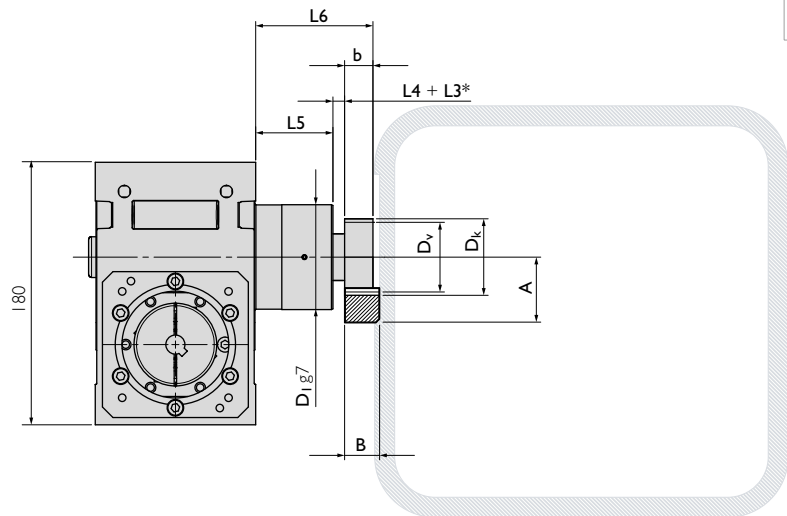

a) The output flange must be supported by the customer supplied equipment at the bearing end (D1), in a hole with an H8 tolerance.

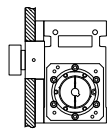

* L3 for additional distance ring.

Helical modular pitch	Part. No.	m_n	P_t	z	A	b	B	D_k	D_0	D_v	D_1	L4	L5	L6
Pinion 1	211220	2	6.66	20	43.220	20	24	46.44	42.441	42.441	72	8	53	81
													58	86
													83	111
Pinion 2	211320	2.5	8.33	20	48.025	25	24	58.05	53.052	53.052	72	8	53	86
													58	91
													83	116
Pinion 3	211416	3	10.00	16	52.365	30	29	58.73	52.930	52.730	72	8	53	91
													58	96
													83	121

m_n : Normal module, P_t : Transverse pitch [mm], z : Number of teeth, D_v : Pitch circle diameter for design, D_0 : Pitch circle diameter for calculation

Straight modular pitch	Part. No.	m_n	P_n	z	A	b	B	D_k	D_0	D_v	D_1	L4	L5	L6
Pinion 4	201220	2	6.28	20	42.000	20	24	44.00	40.000	40.000	72	8	53	81
													58	86
													83	111
Pinion 5	201320	2.5	7.85	20	46.500	25	24	55.00	50.000	50.000	72	8	53	86
													58	91
													83	116
Pinion 6	201416	3	9.42	16	50.900	30	29	55.80	48.000	49.800	72	8	53	91
													58	96
													83	121

m_n : Normal module, P_n : Normal pitch [mm], z : Number of teeth, D_v : Pitch circle diameter for design, D_0 : Pitch circle diameter for calculation

Spacer elements With pinion special solutions on request

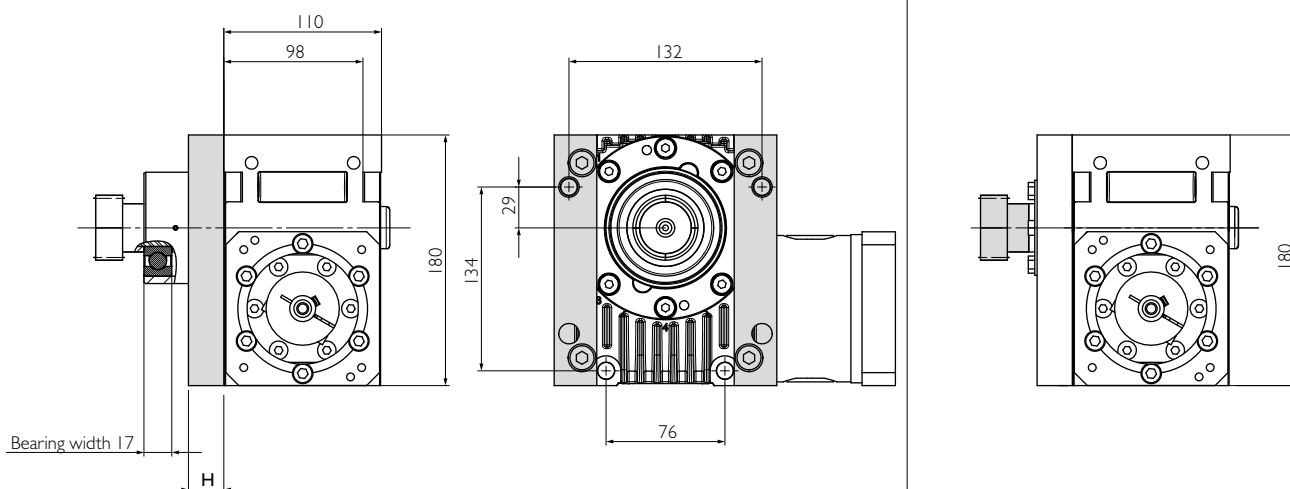

Casing can only be fastened with long screws as per the bore hole pattern.
Screws M6 of length 56mm + H + thread depth, tightening torque 9Nm.

Shrink disc Elastomer coupling

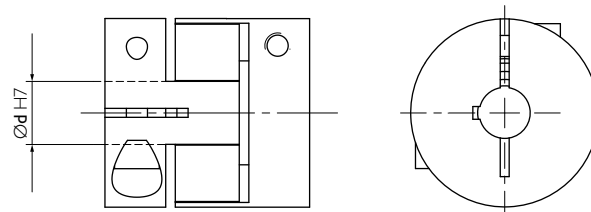
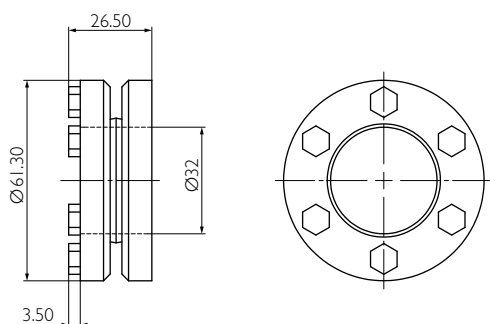

For more details see **Motor Interface** on page 84 et. seq.

Your ideal drive train

Our function package with high-performance angle gearbox, output flange, pinion and rack by Güdel.

			Pinion 1			Pinion 2			Pinion 3			Pinion 4	Pinion 5	Pinion 6
			Q6	Q7	Q9	Q6	Q7	Q9	Q6	Q7	Q9	Q6	Q6	Q6
Max acceleration force	F _{2B}	[N]	7490	2963	5036	11199	4703	8095	15272	4714	12273	5958	9004	12597
Max acceleration torque	T _{2B}	[Nm]	159	63	107	297	125	215	389	120	313	119	225	302
Precision			PR	PS		PR	PS		PR	PS		PR	PS	
Feed force			High	Medium	Elevated	High	Medium	Elevated	High	Medium	Elevated	High	Medium	Elevated

Above values for rack and pinion take into consideration a number of load cycles: 1x10⁶ for the rack; 1x10⁷ for the pinion. Both in pulsating operation.

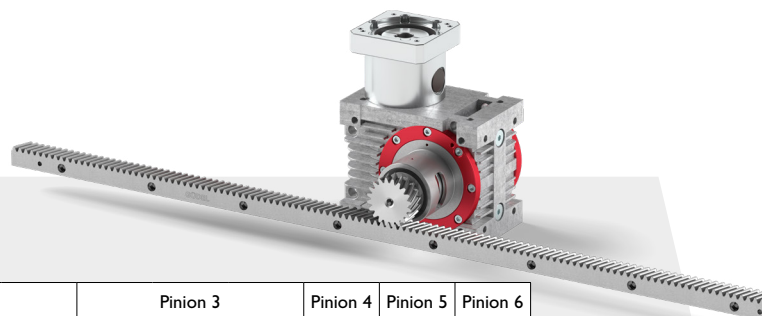

See **rack & pinion program** of your ideal drive train on pages 68 et seq.

See **flowcharts** to find your ideal drive train on pages 86 et seq.

Input

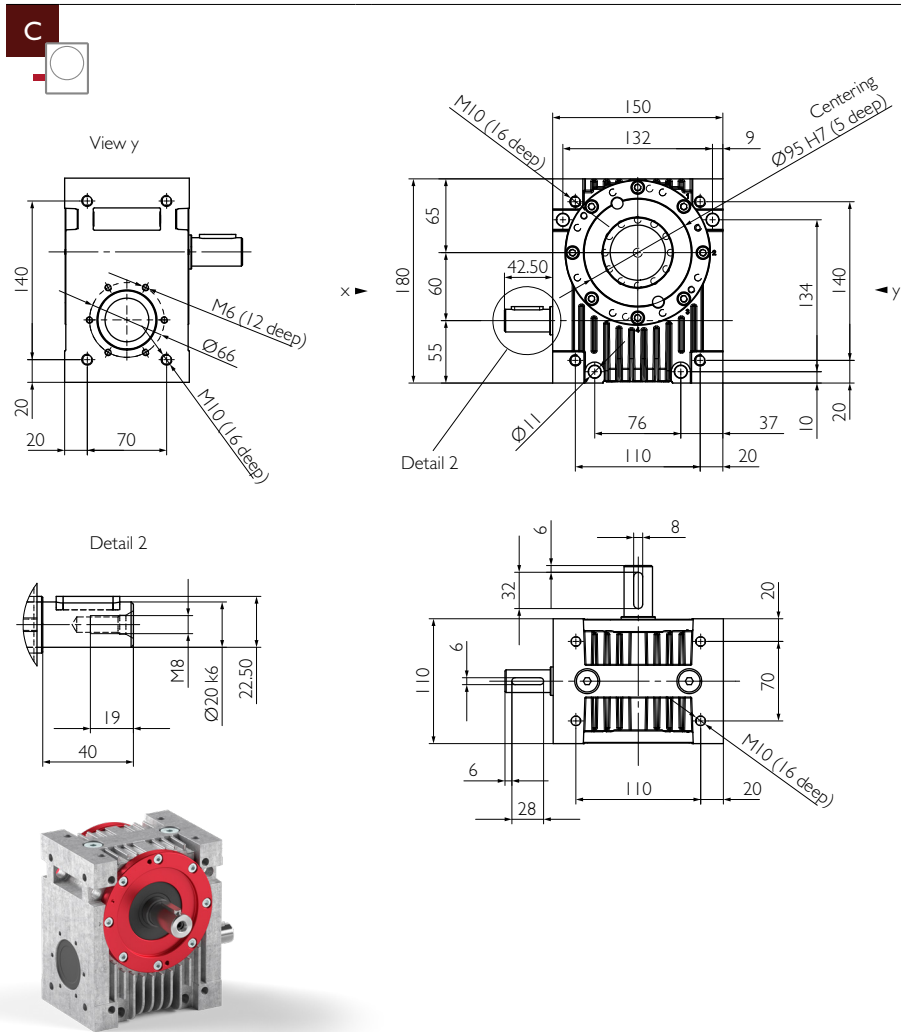

Example HPG 060 C4

C with option motor flange

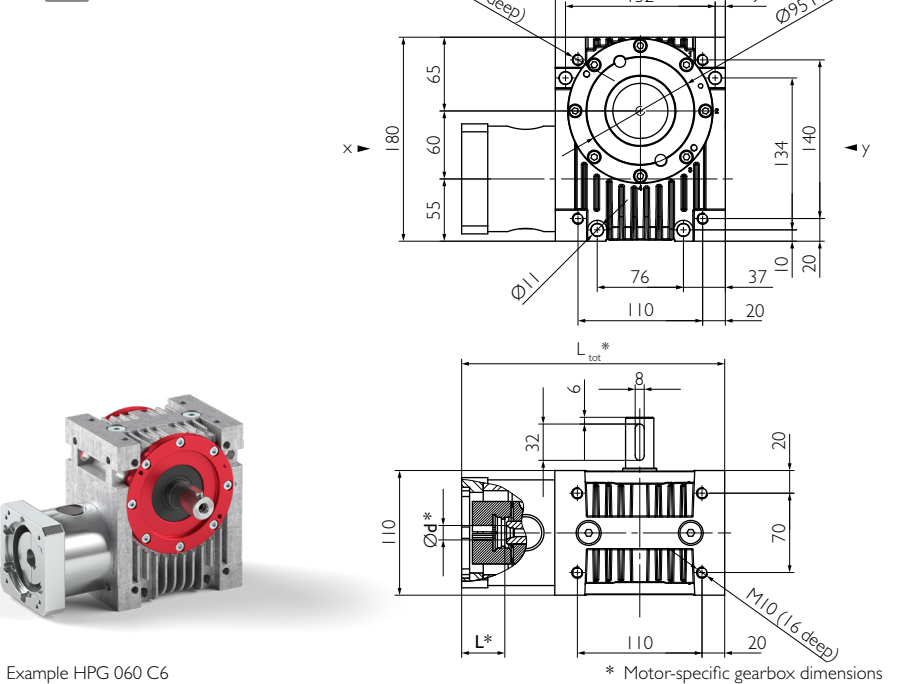

Example HPG 060 C6

* Motor-specific gearbox dimensions

Output

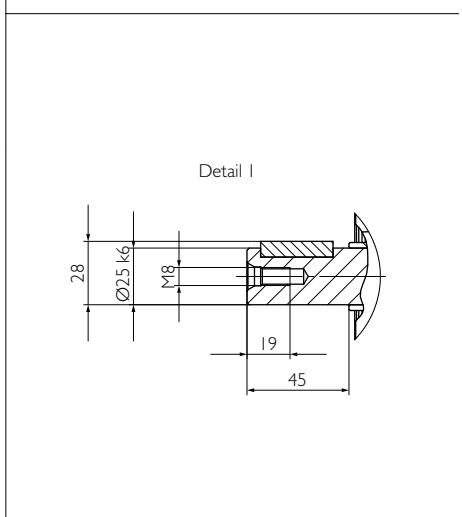
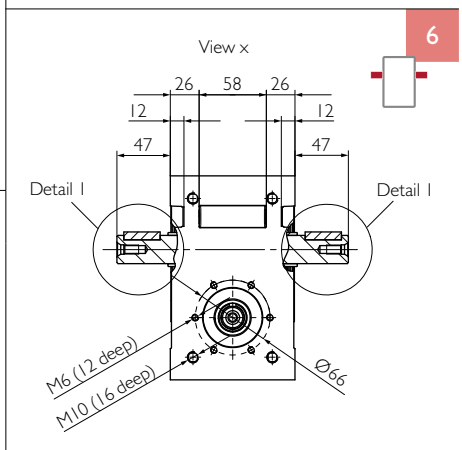
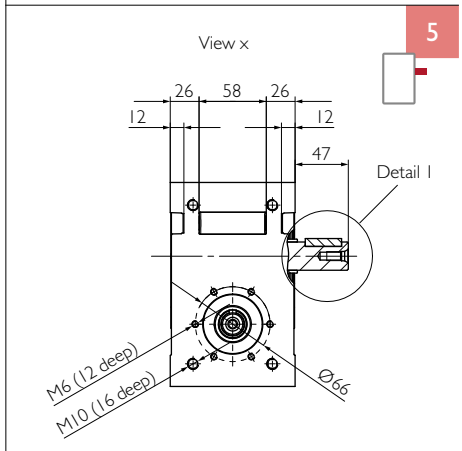
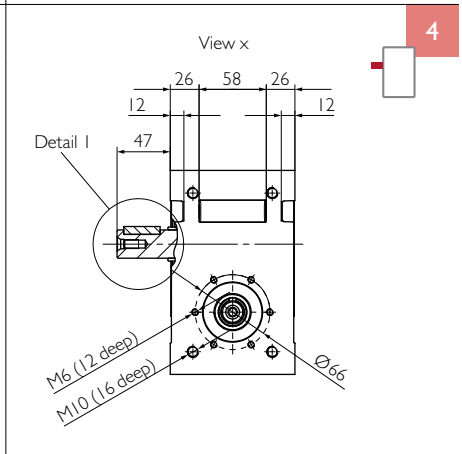

Ratio	i			2	3	4	5	6	8	10	13.33	16	24	30	47	60	
Nominal torque at the output Efficiency	$n_{1N} = 500$ rpm	T_{2N}	[Nm]	135	192	219	211	186	215	199	195	195	202	144	209	144	
		η	[%]	89	89	88	88	87	84	82	78	74	67	64	54	50	50
	$n_{1N} = 1000$ rpm	T_{2N}	[Nm]	107	158	184	180	160	186	173	170	190	185	144	184	144	
		η	[%]	90	90	90	89	88	86	84	81	77	70	65	56	53	
	$n_{1N} = 1500$ rpm	T_{2N}	[Nm]	89	135	159	157	140	164	153	151	168	165	144	163	144	
		η	[%]	90	91	90	89	89	86	84	81	78	70	65	56	52	
	$n_{1N} = 3000$ rpm	T_{2N}	[Nm]	59	93	113	113	103	121	114	113	126	124	126	123	126	
		η	[%]	90	90	90	89	88	86	83	80	77	69	64	55	50	
	$n_{1N} = 4500$ rpm	T_{2N}	[Nm]	44	71	88	89	81	96	91	90	101	99	101	98	101	
		η	[%]	89	89	89	88	87	84	82	78	75	67	61	52	47	
	$n_{1N} = 6000$ rpm	T_{2N}	[Nm]	35	58	71	73	67	80	75	75	84	82	84	82	84	
		η	[%]	88	88	88	87	85	83	80	75	72	64	58	48	44	
Max. acceleration torque		T_{2B}	[Nm]	140	220										150	220	150
Emergency stop torque		T_{2Not}	[Nm]	300										200	300	200	
Idling torque ^{a)}		T_{012}	[Nm]	1.45			1.3			1.1							
Max. input speed		n_{1Max}	[rpm]	6000													
Max. backlash ^{b)} at the output	PS	j_c	[arcmin]	<13	<10	<9	<9	<8	<7						<6		
	PR	j_c	[arcmin]	<9	<7	<6	<6	<5	<4.5						<4		
Torsional rigidity from output to input		C_{t21}	[Nm/arcmin]	2.5	4.8	7.6	8.6	10	11	12.1	13.3	14.5	15.4	15	16	15	
Stability at the output		C_{2K}	[Nm/arcmin]	42													
Max. axial force ^{c)d)} at the output		F_{a2max}	[N]	1300	1700	2600	3600	4400	4100	4500	5100	5300	6500	7300	7500	7500	
Max. radial force ^{c)e)} at the output		F_{r2max}	[N]	1300	1500	2100	2500	2800	2400	2500	2600	2700	3100	3300	3300	3300	
Max. overturning torque ^{c)} at the output		M_{2max}	[Nm]	110	120	170	200	220	190	200	210	220	250	270	270	270	
Max. axial force ^{c)d)} at the input		F_{a1max}	[N]	1700	990	750	1000	1400	1100	1400	1600	1200	1400	1300	1500	1300	
Max. radial force ^{c)f)} at the input		F_{r1max}	[N]	690	510	390	520	720	560	710	760	610	650	620	690	630	
Mass moment of inertia ^{g)}		J_1	[10 ⁻⁶ kg m ²]	467	221	135	95	74	52	42	34	31	27	26	25	25	
Mass moment of inertia ^{g)h)}		J_1	[10 ⁻⁶ kg m ²]	582	336	250	210	189	167	157	149	146	142	141	140	140	
Mass moment of inertia ^{g)i)}		J_1	[10 ⁻⁶ kg m ²]	721	475	389	349	328	306	296	288	285	281	280	279	279	
Service life		L_h	[h]	25000													
Weight without motor components		m	[kg]	9													
Weight with motor components		m	[kg]	≈ 11													
Max. permissible housing temperature			[°C]	+90													
Ambient temperature			[°C]	-15 up to +50													
Lubrication				synthetic gear oil (as per DIN 51502: CLP PG 460)													
Painting				None													
Protection class				IP65													

- a) approximate, at $n_1 = 3000$ rpm and operating temperature.
- b) Precision grade PS (standard backlash) for classic mechanical engineering applications.
Precision grade PR (reduced backlash) for precise process applications.
- c) Bearing forces: Values valid at $n_1 = 3000$ rpm; $\frac{2}{3} T_{2N}$ and duty cycle of 40%.
Consult with Güdel for composite bearing forces, axial and radial forces.
- c) d) in relation to shaft center.
- c) e) at a distance of 80 mm from the middle of the casing.
- c) f) at a distance of 95 mm from the middle of the casing.
- g) in relation to the input.
- g) h) including elastomer coupling 5103-24 (calculated with drilled hole for motor shaft-Ø25)
- g) i) including elastomer coupling 5103-28 (calculated with drilled hole for motor shaft-Ø25)

Bearing forces

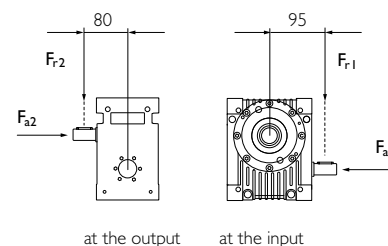

Input

Output

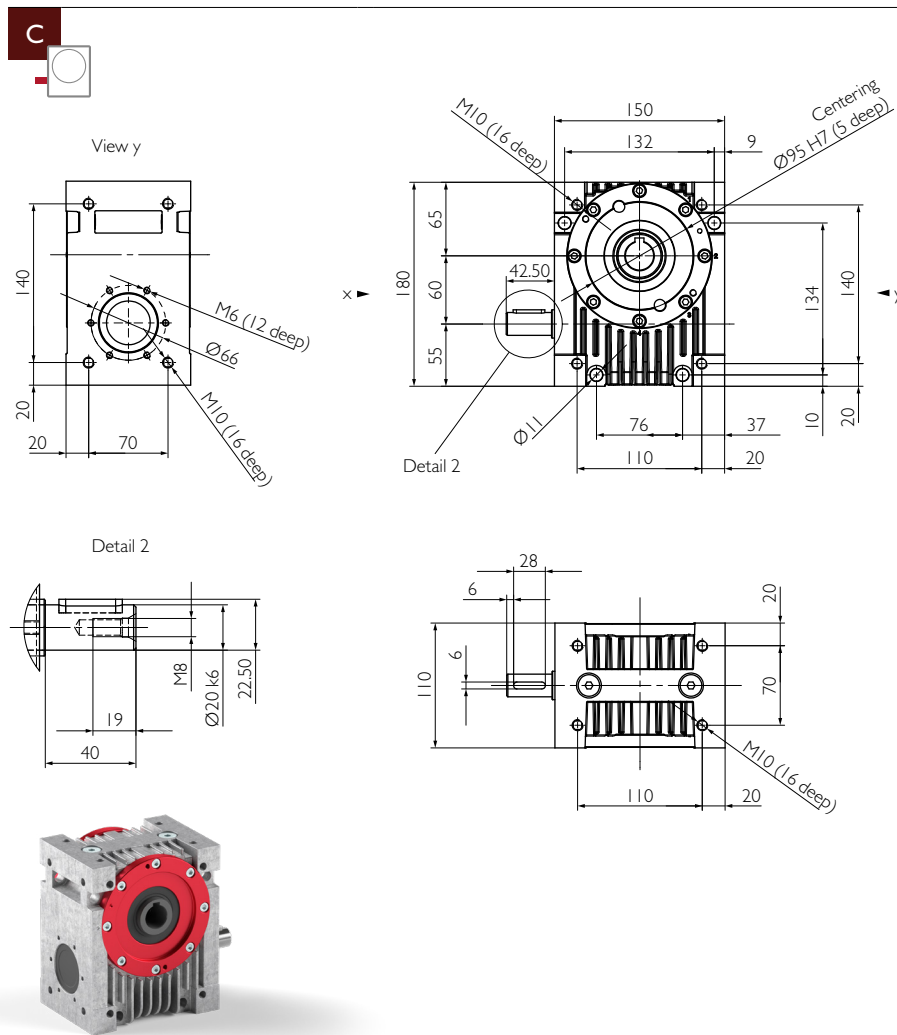

Example HPG 060 C7

C with option motor flange

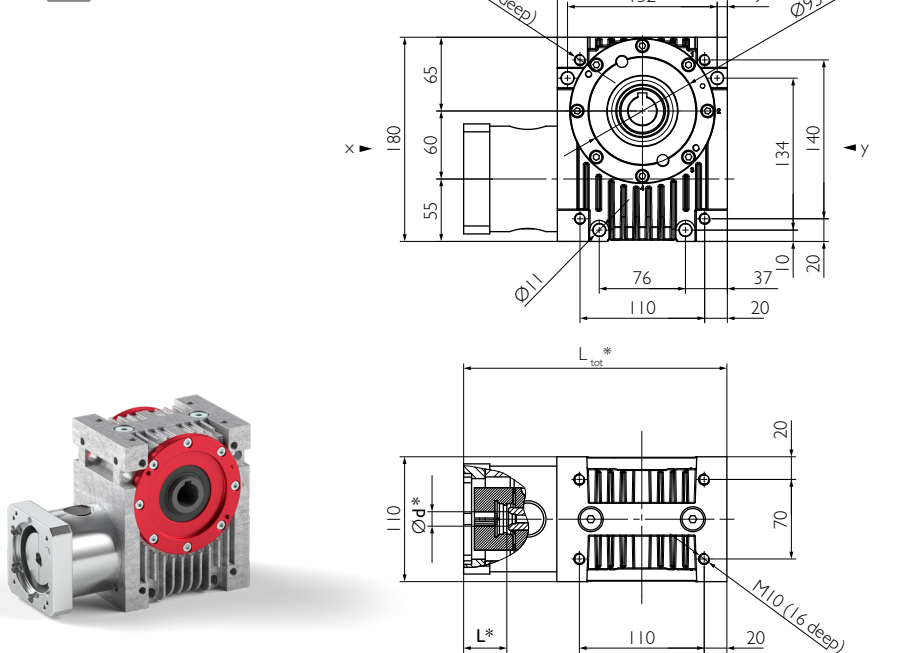

Example HPG 060 C7

* Motor-specific gearbox dimensions

7

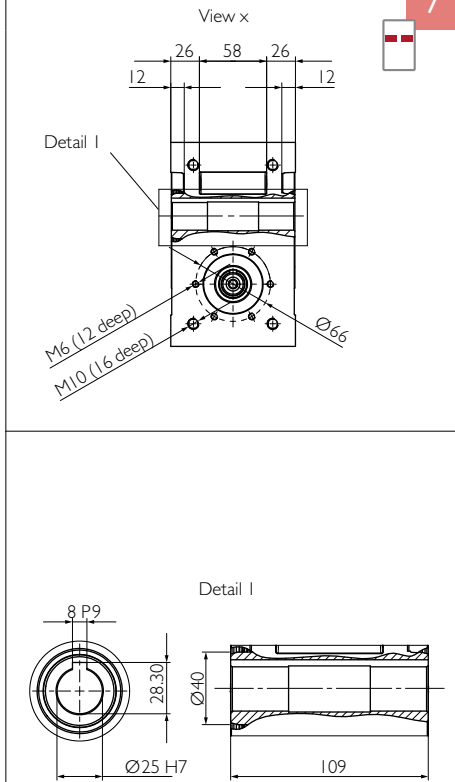

Ratio	i			2	3	4	5	6	8	10	13.33	16	24	30	47	60	
Nominal torque at the output Efficiency	$n_{1N} = 500$ rpm	T_{2N}	[Nm]	135	192	219	211	186	215	199	195	195	202	144	209	144	
		η	[%]	89	89	88	88	87	84	82	78	74	67	64	54	50	50
	$n_{1N} = 1000$ rpm	T_{2N}	[Nm]	107	158	184	180	160	186	173	170	190	185	144	184	144	
		η	[%]	90	90	90	89	88	86	84	81	77	70	65	56	53	
	$n_{1N} = 1500$ rpm	T_{2N}	[Nm]	89	135	159	157	140	164	153	151	168	165	144	163	144	
		η	[%]	90	91	90	89	89	86	84	81	78	70	65	56	52	
	$n_{1N} = 3000$ rpm	T_{2N}	[Nm]	59	93	113	113	103	121	114	113	126	124	126	123	126	
		η	[%]	90	90	90	89	88	86	83	80	77	69	64	55	50	
	$n_{1N} = 4500$ rpm	T_{2N}	[Nm]	44	71	88	89	81	96	91	90	101	99	101	98	101	
		η	[%]	89	89	89	88	87	84	82	78	75	67	61	52	47	
	$n_{1N} = 6000$ rpm	T_{2N}	[Nm]	35	58	71	73	67	80	75	75	84	82	84	82	84	
		η	[%]	88	88	88	87	85	83	80	75	72	64	58	48	44	
Max. acceleration torque		T_{2B}	[Nm]	140	220										150	220	150
Emergency stop torque		T_{2Not}	[Nm]	300										200	300	200	
Idling torque ^{a)}		T_{012}	[Nm]	1.45			1.3			1.1							
Max. input speed		n_{1Max}	[rpm]	6000													
Max. backlash ^{b)} at the output	PS	j_c	[arcmin]	<13	<10	<9	<9	<8	<7						<6		
	PR	j_c	[arcmin]	<9	<7	<6	<6	<5	<4.5						<4		
Torsional rigidity from output to input		C_{t21}	[Nm/arcmin]	2.5	4.8	7.6	8.6	10	11	12.1	13.3	14.5	15.4	15	16	15	
Stability at the output		C_{2K}	[Nm/arcmin]	42													
Max. axial force ^{c)d)} at the output		F_{a2max}	[N]	780	1100	1900	2800	3600	3300	3800	4300	4500	5600	6300	6400	6400	
Max. radial force ^{c)e)} at the output		F_{r2max}	[N]	840	1200	1500	2200	2400	2000	2100	2300	2300	2700	2900	2900	2900	
Max. overturning torque ^{c)} at the output		M_{2max}	[Nm]	67	95	120	170	190	160	170	180	190	220	230	240	230	
Max. axial force ^{c)d)} at the input		F_{a1max}	[N]	1700	990	750	1000	1400	1100	1400	1600	1200	1400	1300	1500	1300	
Max. radial force ^{c)f)} at the input		F_{r1max}	[N]	690	510	390	520	720	560	710	760	610	650	620	690	630	
Mass moment of inertia ^{g)}		J_I	[10 ⁻⁶ kg m ²]	416	199	122	87	68	49	40	33	30	27	26	25	25	
Mass moment of inertia ^{g)h)}		J_I	[10 ⁻⁶ kg m ²]	531	314	237	202	183	164	155	148	145	142	141	140	140	
Mass moment of inertia ^{g)i)}		J_I	[10 ⁻⁶ kg m ²]	670	453	376	341	322	303	294	287	284	281	280	279	279	
Service life		L_h	[h]	25000													
Weight without motor components		m	[kg]	8													
Weight with motor components		m	[kg]	≈ 10													
Max. permissible housing temperature			[°C]	+90													
Ambient temperature			[°C]	-15 up to +50													
Lubrication				synthetic gear oil (as per DIN 51502: CLP PG 460)													
Painting				None													
Protection class				IP65													

- a) approximate, at $n_1 = 3000$ rpm and operating temperature.
- b) Precision grade PS (standard backlash) for classic mechanical engineering applications.
Precision grade PR (reduced backlash) for precise process applications.
- c) Bearing forces: Values valid at $n_1 = 3000$ rpm; $\frac{2}{3} T_{2N}$ and duty cycle of 40%.
Consult with Güdel for composite bearing forces, axial and radial forces.
- c) d) in relation to shaft center.
- c) e) at a distance of 80 mm from the middle of the casing.
- c) f) at a distance of 95 mm from the middle of the casing.
- g) in relation to the input.
- g) h) including elastomer coupling 5103-24 (calculated with drilled hole for motor shaft-Ø20)
- g) i) including elastomer coupling 5103-28 (calculated with drilled hole for motor shaft-Ø25)

Bearing forces

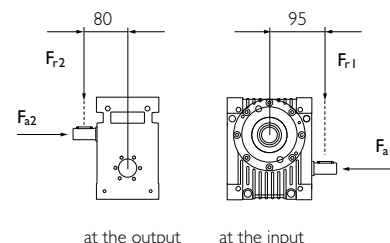

Input

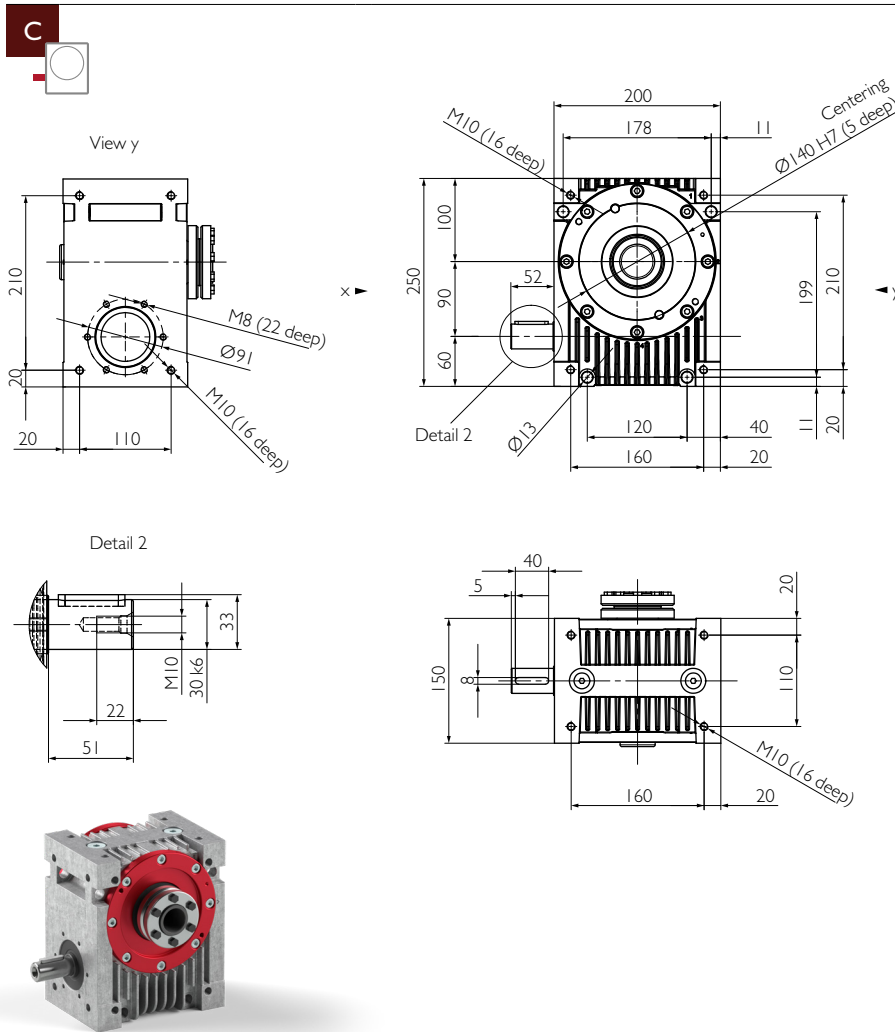

Example HPG 090 C2

C with option motor flange

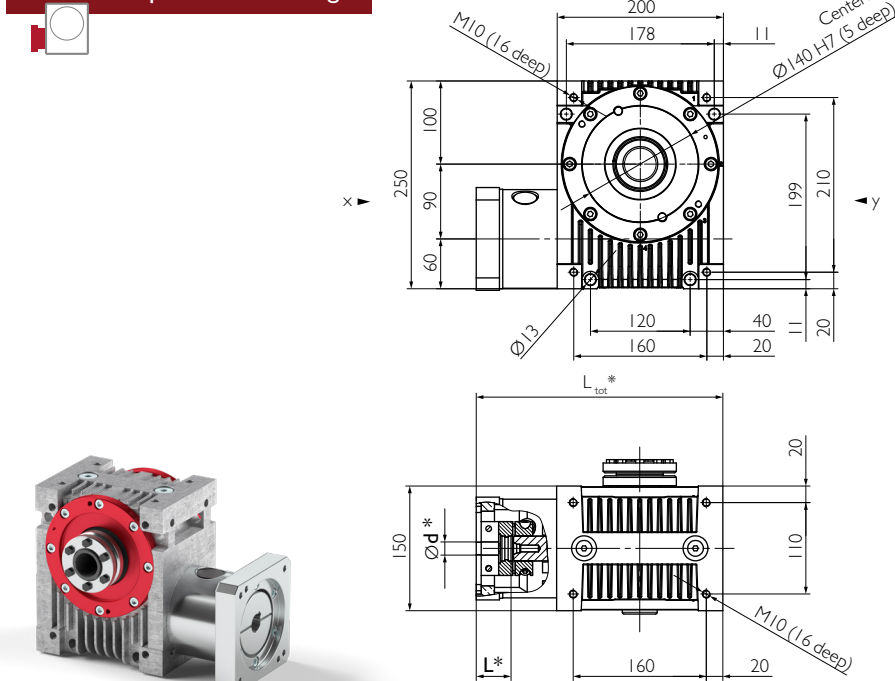

Example HPG 090 C1

* Motor-specific gearbox dimensions

Output

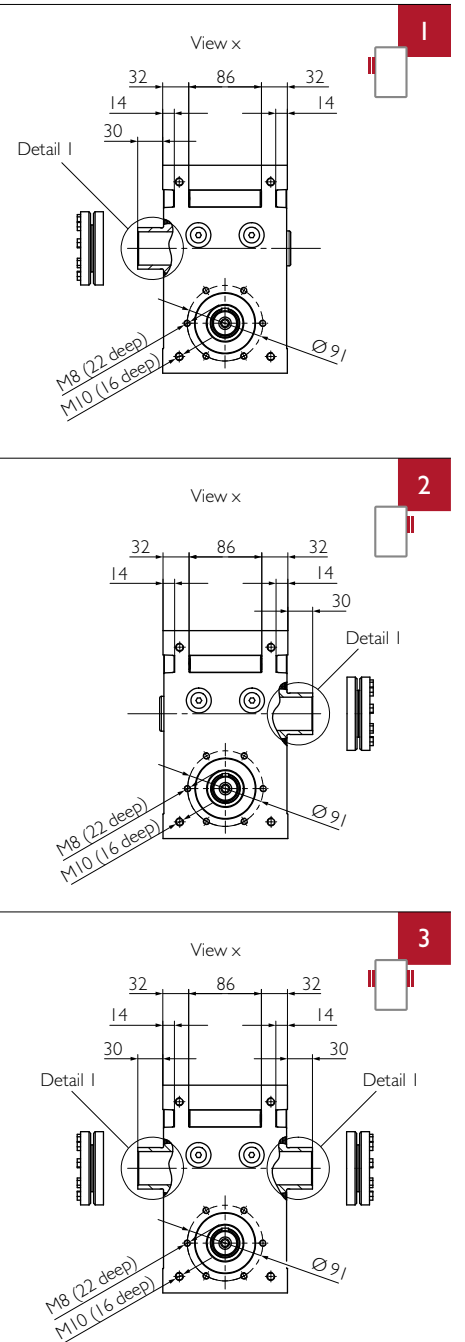

Ratio	i			2	3	4	5	6	8	10	13.33	16	24	30	47	60
Nominal torque at the output Efficiency	n _{1N} = 500 rpm	T _{2N}	[Nm]	469	679	784	761	674	782	726	712	700	727	527	752	527
		η	[%]	92	92	91	91	90	88	87	84	80	74	71	61	50
	n _{1N} = 1000 rpm	T _{2N}	[Nm]	350	528	624	615	551	644	601	592	660	645	527	640	527
		η	[%]	92	92	92	92	91	89	88	85	82	76	72	63	57
	n _{1N} = 1500 rpm	T _{2N}	[Nm]	279	432	518	516	466	547	513	507	565	553	527	550	527
		η	[%]	92	93	92	92	91	90	88	85	83	77	72	64	57
	n _{1N} = 3000 rpm	T _{2N}	[Nm]	174	279	343	348	318	377	356	354	395	388	396	386	396
		η	[%]	92	92	92	92	91	89	88	85	82	76	70	62	55
	n _{1N} = 4500 rpm	T _{2N}	[Nm]	126	206	257	262	241	288	273	272	303	298	305	297	305
		η	[%]	91	92	92	91	90	88	86	83	81	74	68	60	53
Max. acceleration torque		T _{2B}	[Nm]	470	790								530	790	530	
Emergency stop torque		T _{2not}	[Nm]	900								700	900	700		
Idling torque ^{a)}		T ₀₁₂	[Nm]	2.8			2.5			2						
Max. input speed		n _{1Max}	[rpm]	4500												
Max. backlash ^{b)} at the output	PS	j _t	[arcmin]	<10	<8	<7	<7	<6	<6						<5	
	PR	j _t	[arcmin]	<6.5	<5	<4.5	<4	<4	<3.5						<3	
Torsional rigidity from output to input		C _{t21}	[Nm/arcmin]	5.5	10.8	15.9	18.3	20.8	23.3	25.8	28.3	31.3	33.2	32	35	32
Stability at the output		C _{2K}	[Nm/arcmin]	95												
Max. axial force ^{c)d)} at the output		F _{a2max}	[N]	6200	8200	7800	9200	11000	12000	14000	17000	18000	18000	18000	19000	19000
Max. radial force ^{c)e)} at the output		F _{r2max}	[N]	5300	6400	5500	5800	6500	6800	7500	8400	8600	8700	8800	8800	8800
Max. overturning torque ^{c)} at the output		M _{2max}	[Nm]	590	700	600	640	710	750	830	920	940	960	970	970	970
Max. axial force ^{c)d)} at the input		F _{a1max}	[N]	3100	1600	1100	1700	2800	2000	2700	2900	2300	2500	2700	2600	2800
Max. radial force ^{c)f)} at the input		F _{r1max}	[N]	1500	910	640	990	1600	1200	1500	1700	1300	1400	1600	1500	1600
Mass moment of inertia ^{g)}		J _I	[10 ⁻⁵ kg m ²]	336	160	98	70	54	39	32	26	24	21	20	19	19
Mass moment of inertia ^{g)h)}		J _I	[10 ⁻⁵ kg m ²]	362	185	124	95	80	64	57	51	49	46	46	45	45
Mass moment of inertia ^{g)i)}		J _I	[10 ⁻⁵ kg m ²]	403	227	165	136	121	105	98	93	90	88	87	86	86
Service life		L _n	[h]	25000												
Weight without motor components		m	[kg]	23												
Weight with motor components		m	[kg]	≈ 27												
Max. permissible housing temperature			[°C]	+90												
Ambient temperature			[°C]	-15 up to +50												
Lubrication				synthetic gear oil (as per DIN 51502: CLP PG 460)												
Painting				None												
Protection class				IP65												

- a) approximate, at n₁ = 3000 rpm and operating temperature.
- b) Precision grade PS (standard backlash) for classic mechanical engineering applications.
Precision grade PR (reduced backlash) for precise process applications.
- c) Bearing forces: Values valid at n₁ = 1500 rpm; 1/2 T_{2N} and duty cycle of 40%.
Consult with Güdel for composite bearing forces, axial and radial forces.
- c) d) in relation to shaft center.
- c) e) at a distance of 110 mm from the middle of the casing.
- c) f) at a distance of 125 mm from the middle of the casing.
- g) in relation to the input, including shrink disc at the output (output 1 & 2),
with two shrink discs (output 3) increase values by 115/i².
- g) h) including elastomer coupling 5103-28 (calculated with drilled hole for motor shaft-Ø25)
- g) i) including elastomer coupling 5103-38 (calculated with drilled hole for motor shaft-Ø45)

Bearing forces

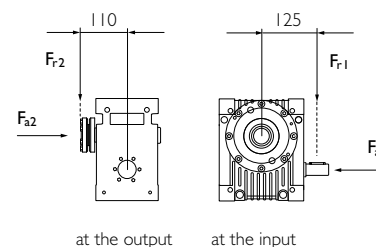

Package

		Output flange including bearing & pinion					
Radial rigidity	C ₃	[N/mm]	45000				
Speed	n _{2N}	[rpm]	1500	750	400	150	100
Max. radial force ^{j)}	F _{rmax}	[N]	4800	5900	7200	8800	9700

j) Bearing forces: Values valid at duty cycle of 40% at a distance of 25mm from the end of the bearing.

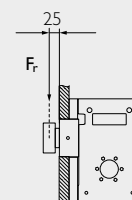

Detailed information about the package, options & accessories on pages 52 and 53.

Output flange including bearing & pinion a)

Package

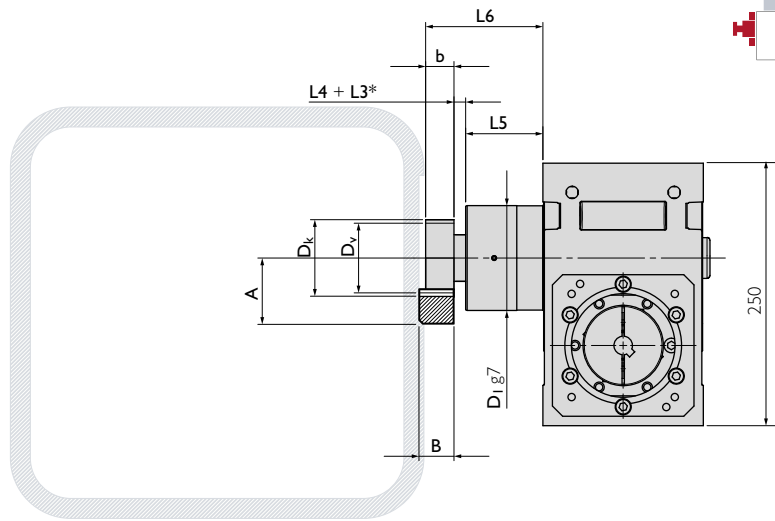
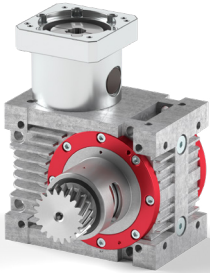

Example HPG 090 C2 Package

Package

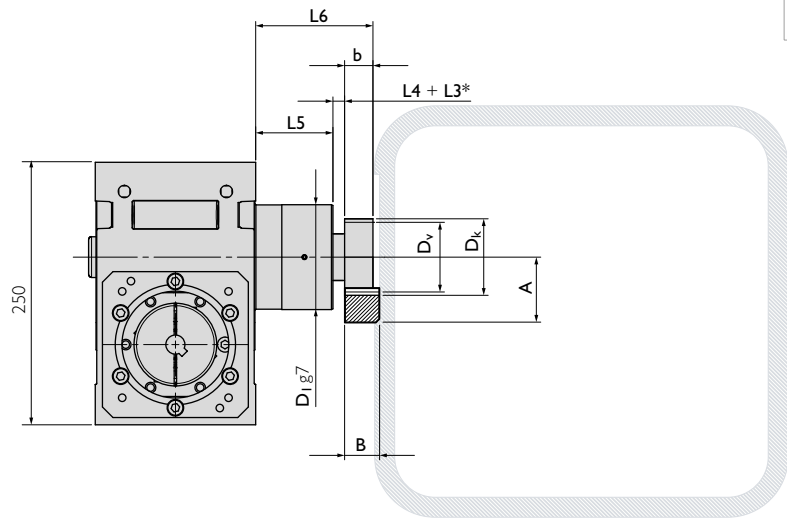

a) The output flange must be supported by the customer supplied equipment at the bearing end (D1), in a hole with an H8 tolerance.

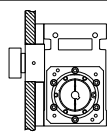

* L3 for additional distance ring.

Geometric information

Helical modular pitch	Part. No.	m_n	P_t	z	A	b	B	D_k	D_0	D_v	D_1	L4	L5	L6
Pinion 1	211420	3	10.00	20	57.83	30	29	69.66	63.662	63.662	98	12.5	63.0	105.5
													104.5	147.0
Pinion 2	211520	4	13.33	20	77.44	40	39	92.88	84.883	84.883	98	18.0	63.0	121.0
													104.5	162.5

m_n : Normal module, P_t : Transverse pitch [mm], z : Number of teeth, D_v : Pitch circle diameter for design, D_0 : Pitch circle diameter for calculation

Straight modular pitch	Part. No.	m_n	P_n	z	A	b	B	D_k	D_0	D_v	D_1	L4	L5	L6
Pinion 3	201420	3	9.42	20	56.00	30	29	66.00	60.000	60.000	98	12.5	63.0	105.5
													104.5	147.0
Pinion 4	201520	4	12.57	20	75.00	40	39	88.00	80.000	80.000	98	18.0	63.0	121.0
													104.5	162.5

m_n : Normal module, P_n : Normal pitch [mm], z : Number of teeth, D_v : Pitch circle diameter for design, D_0 : Pitch circle diameter for calculation

Spacer elements

With pinion special solutions on request

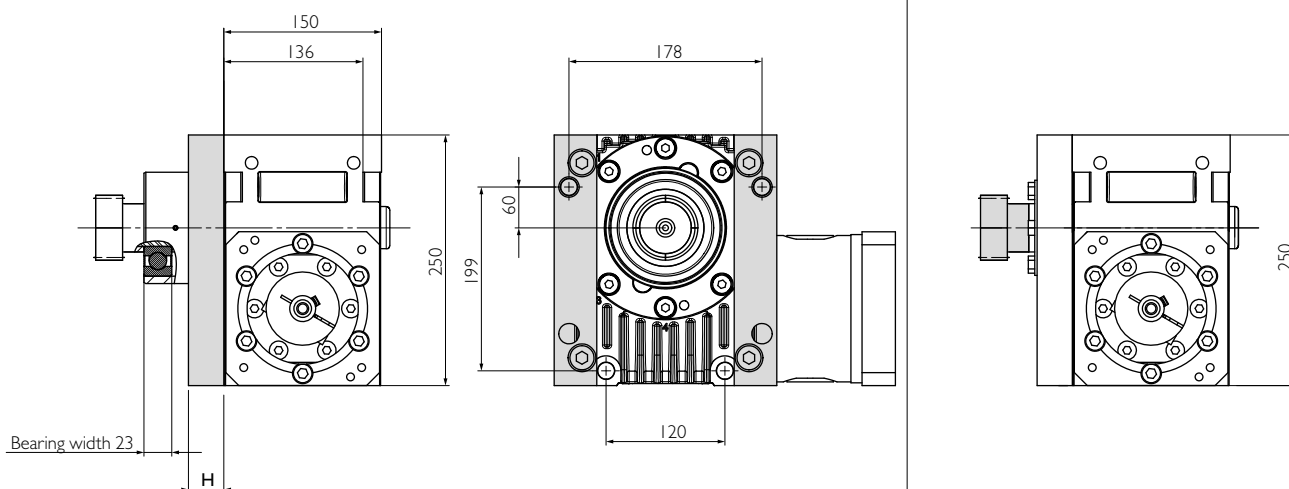

Casing can only be fastened with long screws as per the bore hole pattern.
Screws M6 of length 56mm + H + thread depth, tightening torque 9Nm.

Shrink disc

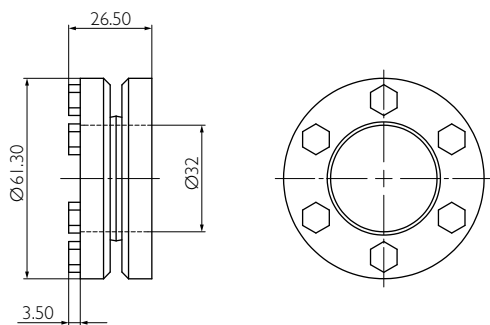

Elastomer coupling

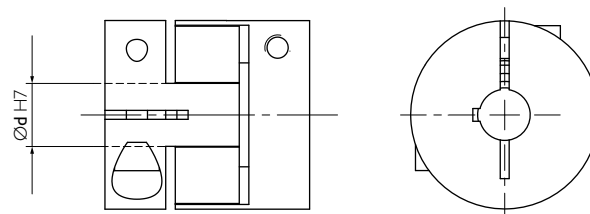

For more details see **Motor Interface** on page 84 et. seq.

Your ideal drive train

Our function package with high-performance angle gearbox, output flange, pinion and rack by Güdel.

			Pinion 1			Pinion 2			Pinion 3	Pinion 4
			Q6	Q7	Q9	Q6	Q7	Q9	Q6	Q6
Max acceleration force	F _{2B}	[N]	16163	7565	12980	28585	14084	24045	13697	24068
Max acceleration torque	T _{2B}	[Nm]	515	241	413	1213	598	1021	411	963
Precision			PR	PS		PR	PS			
Feed force			High	Medium	Elevated	High	Medium	Elevated		

Above values for rack and pinion take into consideration a number of load cycles: 1x10⁶ for the rack; 1x10⁷ for the pinion. Both in pulsating operation.

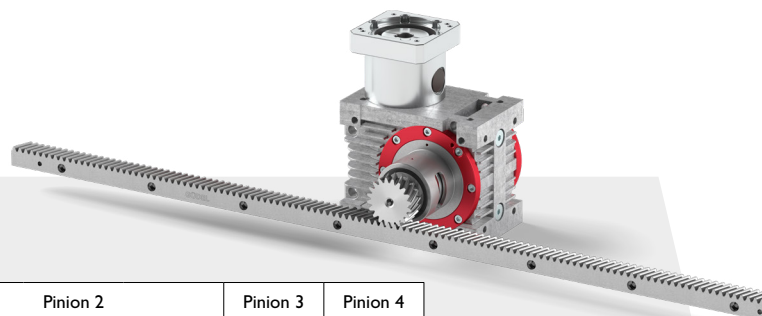

See **rack & pinion program** of your ideal drive train on pages 68 et seq.

See **flowcharts** to find your ideal drive train on pages 86 et seq.

Input

Output

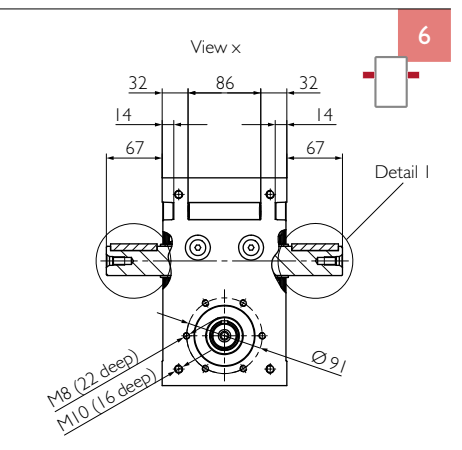
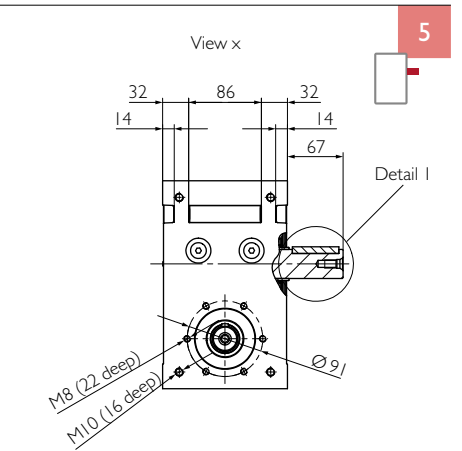
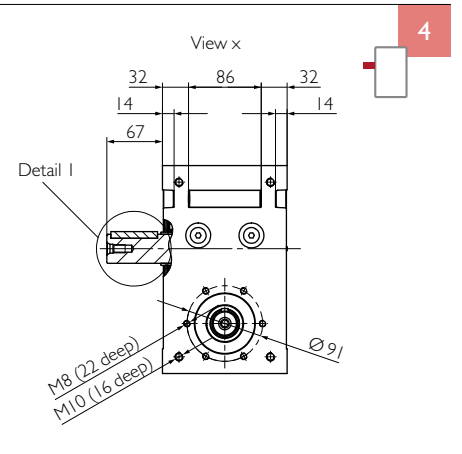
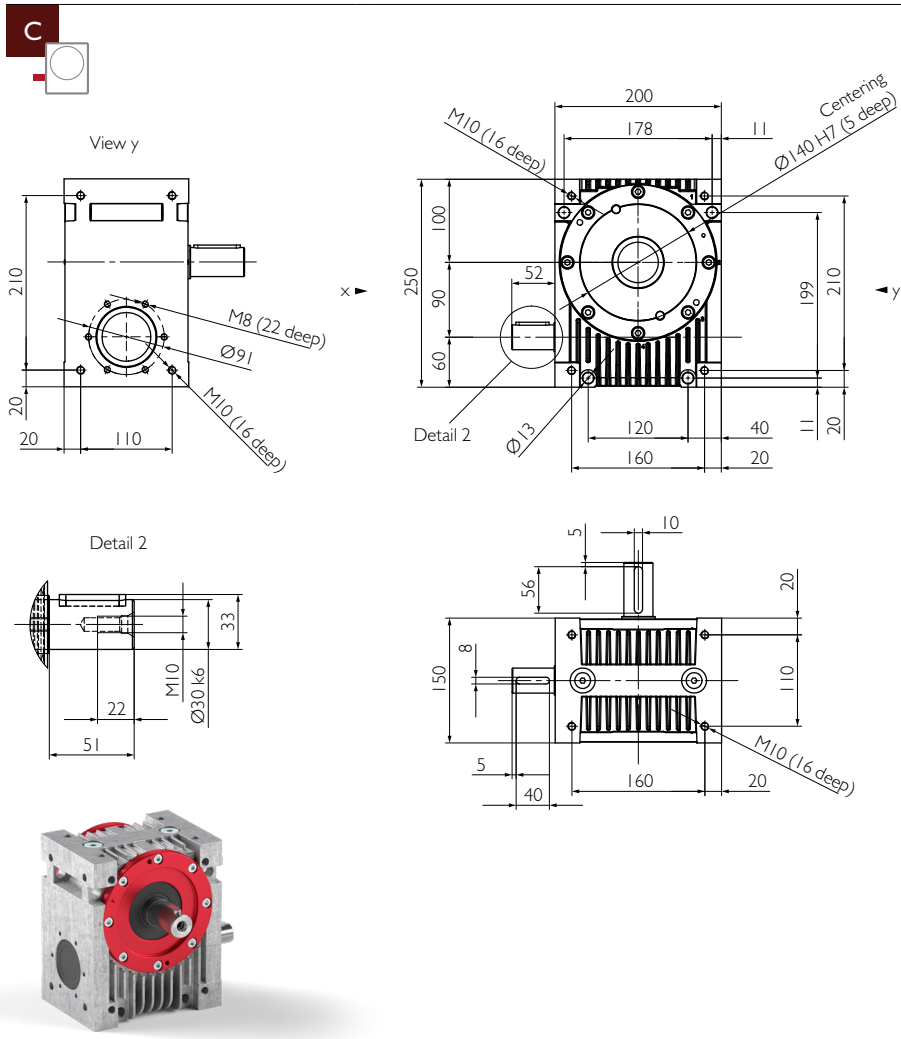

Example HPG 090 C4

C with option motor flange

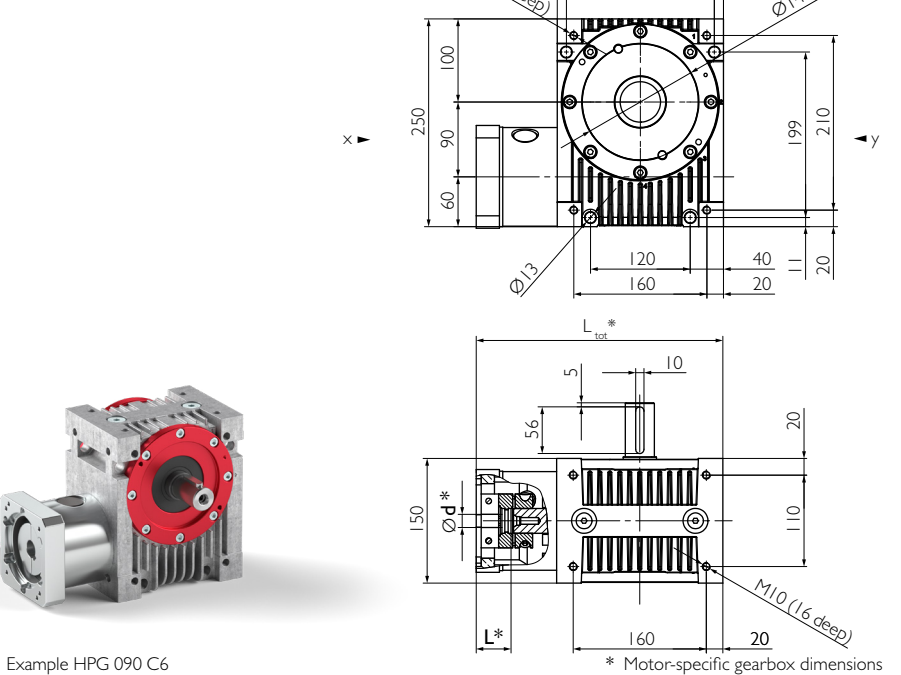

Example HPG 090 C6

Ratio	i			2	3	4	5	6	8	10	13.33	16	24	30	47	60
Nominal torque at the output Efficiency	n _{1N} = 500 rpm	T _{2N}	[Nm]	469	679	784	761	674	782	726	712	700	727	527	752	527
		η	[%]	92	92	91	91	90	88	87	84	80	74	71	61	50
	n _{1N} = 1000 rpm	T _{2N}	[Nm]	350	528	624	615	551	644	601	592	660	645	527	640	527
		η	[%]	92	92	92	92	91	89	88	85	82	76	72	63	57
	n _{1N} = 1500 rpm	T _{2N}	[Nm]	279	432	518	516	466	547	513	507	565	553	527	550	527
		η	[%]	92	93	92	92	91	90	88	85	83	77	72	64	57
	n _{1N} = 3000 rpm	T _{2N}	[Nm]	174	279	343	348	318	377	356	354	395	388	396	386	396
		η	[%]	92	92	92	92	91	89	88	85	82	76	70	62	55
	n _{1N} = 4500 rpm	T _{2N}	[Nm]	126	206	257	262	241	288	273	272	303	298	305	297	305
		η	[%]	91	92	92	91	90	88	86	83	81	74	68	60	53
Max. acceleration torque		T _{2B}	[Nm]	470	790								530	790	530	
Emergency stop torque		T _{2Not}	[Nm]	900								700	900	700		
Idling torque ^{a)}		T ₀₁₂	[Nm]	2.8			2.5			2						
Max. input speed		n _{1Max}	[rpm]	4500												
Max. backlash ^{b)} at the output	PS	j _t	[arcmin]	<10	<8	<7	<7	<6	<6						<5	
	PR	j _t	[arcmin]	<6.5	<5	<4.5	<4	<4	<3.5						<3	
Torsional rigidity from output to input		C _{t21}	[Nm/arcmin]	5.5	10.8	15.9	18.3	20.8	23.3	25.8	28.3	31.3	33.2	32	35	32
Stability at the output		C _{2K}	[Nm/arcmin]	73												
Max. axial force ^{c)d)} at the output		F _{a2max}	[N]	820	1400	1400	2800	4400	5000	6600	8300	8100	8700	9100	9200	9400
Max. radial force ^{c)e)} at the output		F _{r2max}	[N]	800	930	1000	1400	3000	3100	3700	4200	4300	4400	4500	4500	4600
Max. overturning torque ^{c)} at the output		M _{2max}	[Nm]	88	100	110	160	330	350	400	460	470	490	500	500	500
Max. axial force ^{c)d)} at the input		F _{a1max}	[N]	3100	1600	1100	1700	2800	2000	2700	2900	2300	2500	2700	2600	2800
Max. radial force ^{c)f)} at the input		F _{r1max}	[N]	1500	910	640	990	1600	1200	1500	1700	1300	1400	1600	1500	1600
Mass moment of inertia ^{g)}		J _I	[10 ⁻⁵ kg m ²]	336	160	98	70	54	39	32	26	24	21	20	19	19
Mass moment of inertia ^{g)h)}		J _I	[10 ⁻⁵ kg m ²]	362	185	124	95	80	64	57	51	49	46	46	45	45
Mass moment of inertia ^{g)i)}		J _I	[10 ⁻⁵ kg m ²]	403	227	165	136	121	105	98	93	90	88	87	86	86
Service life		L _n	[h]	25000												
Weight without motor components		m	[kg]	22												
Weight with motor components		m	[kg]	≈ 26												
Max. permissible housing temperature			[°C]	+90												
Ambient temperature			[°C]	-15 up to +50												
Lubrication				synthetic gear oil (as per DIN 51502: CLP PG 460)												
Painting				None												
Protection class				IP65												

- a) approximate, at n₁ = 3000 rpm and operating temperature.
- b) Precision grade PS (standard backlash) for classic mechanical engineering applications.
Precision grade PR (reduced backlash) for precise process applications.
- c) Bearing forces: Values valid at n₁ = 1500 rpm; ½ T_{2N} and duty cycle of 40%.
Consult with Güdel for composite bearing forces, axial and radial forces.
- c d) in relation to shaft center.
- c e) at a distance of 110 mm from the middle of the casing.
- c f) at a distance of 125 mm from the middle of the casing.
- g) in relation to the input.
- g h) including elastomer coupling 5103-28 (calculated with drilled hole for motor shaft-Ø25)
- g i) including elastomer coupling 5103-38 (calculated with drilled hole for motor shaft-Ø45)

Bearing forces

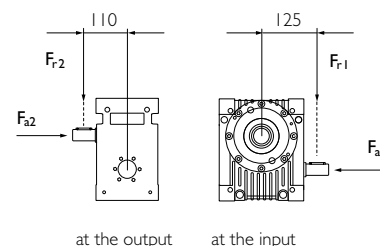

Input

Output

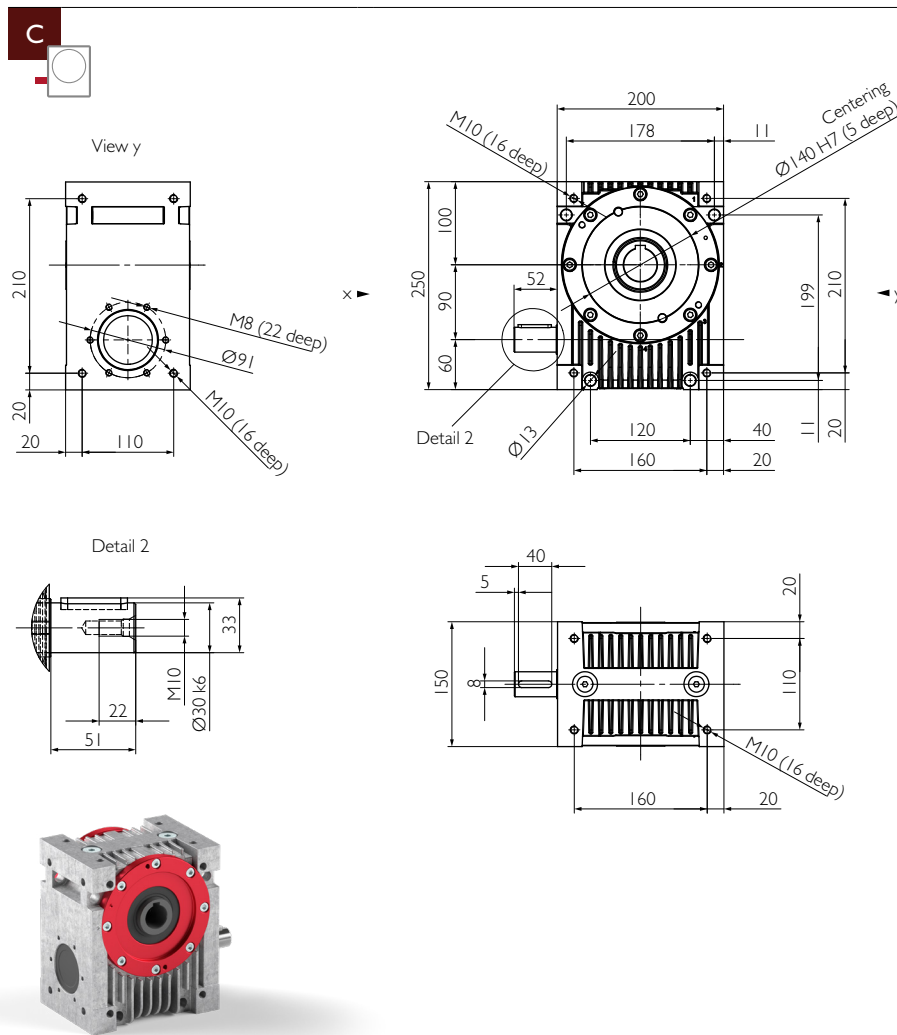

Example HPG 090 C7

C with option motor flange

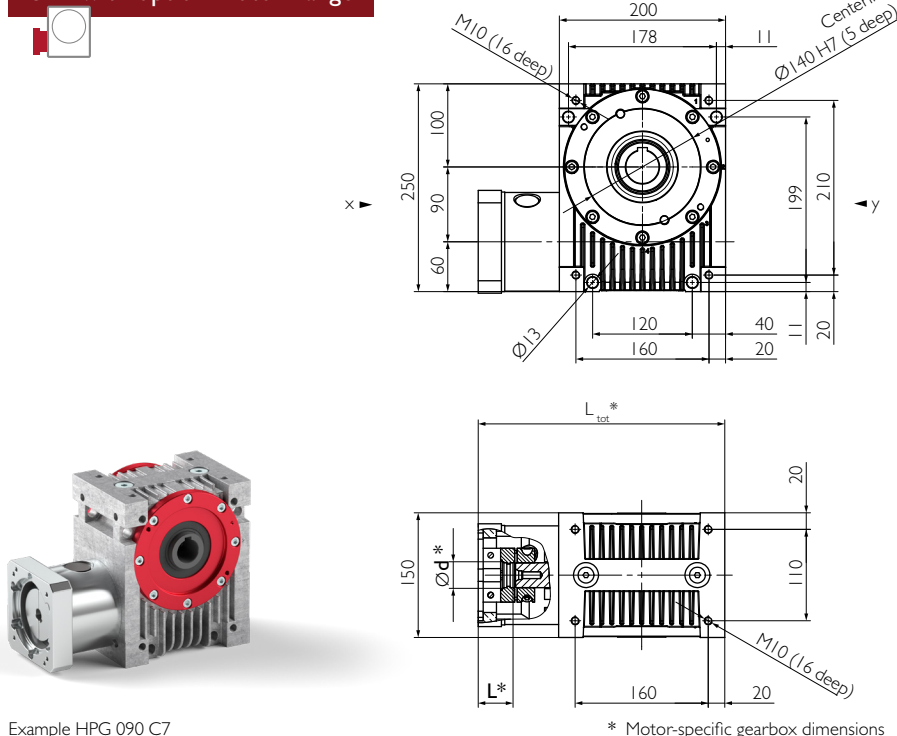

Example HPG 090 C7

* Motor-specific gearbox dimensions

Ratio	i			2	3	4	5	6	8	10	13.33	16	24	30	47	60
Nominal torque at the output Efficiency	n _{1N} = 500rpm	T _{2N}	[Nm]	469	679	784	761	674	782	726	712	700	727	527	752	527
		η	[%]	92	92	91	91	90	88	87	84	80	74	71	61	50
	n _{1N} = 1000rpm	T _{2N}	[Nm]	350	528	624	615	551	644	601	592	660	645	527	640	527
		η	[%]	92	92	92	92	91	89	88	85	82	76	72	63	57
	n _{1N} = 1500rpm	T _{2N}	[Nm]	279	432	518	516	466	547	513	507	565	553	527	550	527
		η	[%]	92	93	92	92	91	90	88	85	83	77	72	64	57
	n _{1N} = 3000rpm	T _{2N}	[Nm]	174	279	343	348	318	377	356	354	395	388	396	386	396
		η	[%]	92	92	92	92	91	89	88	85	82	76	70	62	55
	n _{1N} = 4500rpm	T _{2N}	[Nm]	126	206	257	262	241	288	273	272	303	298	305	297	305
		η	[%]	91	92	92	91	90	88	86	83	81	74	68	60	53
Max. acceleration torque		T _{2B}	[Nm]	470	790								530	790	530	
Emergency stop torque		T _{2not}	[Nm]	900								700	900	700		
Idling torque ^{a)}		T ₀₁₂	[Nm]	2.8			2.5			2						
Max. input speed		n _{1Max}	[rpm]	4500												
Max. backlash ^{b)} at the output	PS	j _t	[arcmin]	<10	<8	<7	<7	<6	<6						<5	
	PR	j _t	[arcmin]	<6.5	<5	<4.5	<4	<4	<3.5						<3	
Torsional rigidity from output to input		C _{t21}	[Nm/arcmin]	5.5	10.8	15.9	18.3	20.8	23.3	25.8	28.3	31.3	33.2	32	35	32
Stability at the output		C _{2K}	[Nm/arcmin]	95												
Max. axial force ^{c)d)} at the output		F _{a2max}	[N]	6200	8200	7800	9200	11000	12000	14000	17000	18000	18000	18000	19000	19000
Max. radial force ^{c)e)} at the output		F _{r2max}	[N]	5300	6400	5500	5800	6500	6800	7500	8400	8600	8700	8800	8800	8800
Max. overturning torque ^{c)} at the output		M _{2max}	[Nm]	590	700	600	640	710	750	830	920	940	960	970	970	970
Max. axial force ^{c)d)} at the input		F _{a1max}	[N]	3100	1600	1100	1700	2800	2000	2700	2900	2300	2500	2700	2600	2800
Max. radial force ^{c)f)} at the input		F _{r1max}	[N]	1500	910	640	990	1600	1200	1500	1700	1300	1400	1600	1500	1600
Mass moment of inertia ^{g)}		J _I	[10 ⁻⁵ kg m ²]	308	147	91	65	51	37	30	25	23	21	20	19	19
Mass moment of inertia ^{g)h)}		J _I	[10 ⁻⁵ kg m ²]	333	173	116	90	76	62	56	51	49	46	46	45	45
Mass moment of inertia ^{g)i)}		J _I	[10 ⁻⁵ kg m ²]	374	214	158	132	118	103	97	92	90	87	87	86	86
Service life		L _n	[h]	25000												
Weight without motor components		m	[kg]	22												
Weight with motor components		m	[kg]	≈ 26												
Max. permissible housing temperature			[°C]	+90												
Ambient temperature			[°C]	-15 up to +50												
Lubrication				synthetic gear oil (as per DIN 51502: CLP PG 460)												
Painting				None												
Protection class				IP65												

- a) approximate, at n₁ = 3000 rpm and operating temperature.
- b) Precision grade PS (standard backlash) for classic mechanical engineering applications.
Precision grade PR (reduced backlash) for precise process applications.
- c) Bearing forces: Values valid at n₁ = 1500 rpm; ½ T_{2N} and duty cycle of 40%.
Consult with Güdel for composite bearing forces, axial and radial forces.
- c d) in relation to shaft center.
- c e) at a distance of 110 mm from the middle of the casing.
- c f) at a distance of 125 mm from the middle of the casing.
- g) in relation to the input.
- g h) including elastomer coupling 5103-28 (calculated with drilled hole for motor shaft-Ø25)
- g i) including elastomer coupling 5103-38 (calculated with drilled hole for motor shaft-Ø45)

Bearing forces

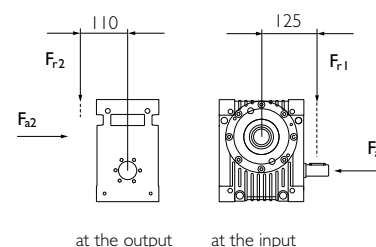

Ratio	i			2	3	4	5	6	8	10	13.33	16	24	30	47	60
Nominal torque at the output Efficiency	n _{1N} = 500 rpm	T _{2N}	[Nm]	1177	1732	2018	1969	1752	2038	1895	1863	1824	1900	1364	1970	1364
		η	[%]	93	93	93	93	92	90	89	87	84	78	75	66	61
	n _{1N} = 1000 rpm	T _{2N}	[Nm]	836	1284	1534	1523	1371	1609	1505	1487	1658	1622	1364	1612	1364
		η	[%]	94	94	94	93	93	91	90	88	85	80	76	68	62
	n _{1N} = 1500 rpm	T _{2N}	[Nm]	648	1020	1237	1241	1126	1329	1248	1237	1380	1353	1364	1345	1364
		η	[%]	94	94	94	93	93	91	90	88	86	80	76	69	62
	n _{1N} = 3000 rpm	T _{2N}	[Nm]	387	631	783	798	733	873	826	822	918	903	921	899	921
		η	[%]	93	94	93	93	93	91	90	88	85	80	74	68	60
	n _{1N} = 4500 rpm	T _{2N}	[Nm]	276	457	573	588	543	650	617	616	688	677	689	675	689
		η	[%]	93	93	93	93	92	89	87	84	79	73	66	58	
Max. acceleration torque		T _{2B}	[Nm]	1200	2040									1400	2040	1400
Emergency stop torque		T _{2not}	[Nm]	2300									1600	2300	1600	
Idling torque ^{a)}		T ₀₁₂	[Nm]	4.5			4			3						
Max. input speed		n _{1Max}	[rpm]	4500												
Max. backlash ^{b)} at the output	PS	j _t	[arcmin]	<8	<7	<6	<6	<5	<5						<4	
	PR	j _t	[arcmin]	<5.5	<4.5	<4	<3.5	<3	<3						<2.5	
Torsional rigidity from output to input		C _{t21}	[Nm/arcmin]	11.5	19	24.5	26.5	29	31.5	34	36.5	38.5	40.5	39	42.5	39
Stability at the output		C _{2K}	[Nm/arcmin]	165												
Max. axial force ^{c)d)} at the output		F _{a2max}	[N]	7000	9600	9500	12000	16000	17000	21000	25000	26000	27000	27000	27000	28000
Max. radial force ^{c)e)} at the output		F _{r2max}	[N]	7700	8100	7300	8800	9900	10000	12000	13000	13000	14000	14000	14000	14000
Max. overturning torque ^{c)} at the output		M _{2max}	[Nm]	1000	1100	980	1200	1300	1400	1600	1800	1800	1800	1800	1900	1900
Max. axial force ^{c)d)} at the input		F _{a1max}	[N]	3600	1800	730	1700	3600	2100	3300	3700	2500	2900	2700	3100	2700
Max. radial force ^{c)f)} at the input		F _{r1max}	[N]	1900	950	390	930	1900	1200	1800	2000	1300	1600	1400	1700	1500
Mass moment of inertia ^{g)}		J _I	[10 ⁻⁵ kg m ²]	1392	660	403	285	220	156	127	103	94	83	80	76	75
Mass moment of inertia ^{g)h)}		J _I	[10 ⁻⁵ kg m ²]	1459	726	470	351	287	223	193	170	161	150	146	143	142
Mass moment of inertia ^{g)i)}		J _I	[10 ⁻⁵ kg m ²]	1574	842	585	467	402	338	309	285	276	265	262	258	257
Service life		L _n	[h]	25000												
Weight without motor components		m	[kg]	48												
Weight with motor components		m	[kg]	≈ 53												
Max. permissible housing temperature			[°C]	+90												
Ambient temperature			[°C]	-15 up to +50												
Lubrication	synthetic gear oil (as per DIN 51502: CLP PG 460)															
Painting	None															
Protection class	IP65															

- a) approximate, at n₁ = 3000 rpm and operating temperature.
- b) Precision grade PS (standard backlash) for classic mechanical engineering applications.
Precision grade PR (reduced backlash) for precise process applications.
- c) Bearing forces: Values valid at n₁ = 1500 rpm; ½ T_{2N} and duty cycle of 40%. Consult with Güdel for composite bearing forces, axial and radial forces.
- c) d) in relation to shaft center.
- c) e) at a distance of 135 mm from the middle of the casing.
- c) f) at a distance of 160 mm from the middle of the casing.
- g) in relation to the input, including shrink disc at the output (output 1 & 2), with two shrink discs (output 3) increase values by 340/i².
- g) h) including elastomer coupling 5103-38 (calculated with drilled hole for motor shaft-Ø45)
- g) i) including elastomer coupling 5103-42 (calculated with drilled hole for motor shaft-Ø44)

Bearing forces

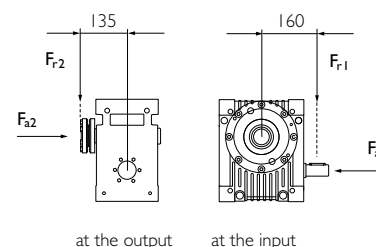

Package

		Output flange including bearing & pinion					
Radial rigidity	C ₃	[N/mm]	47000				
Speed	n _{2N}	[rpm]	1500	750	400	150	100
Max. radial force ^{j)}	F _{rmax}	[N]	11500	13000	17000	21000	24000

j) Bearing forces: Values valid at duty cycle of 40% at a distance of 50 mm from the end of the bearing.

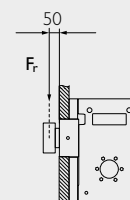

Output flange including bearing & pinion a)

Package

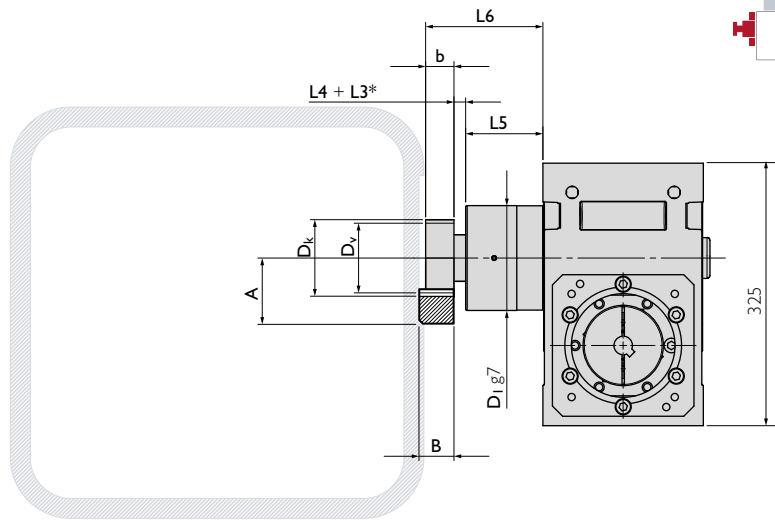
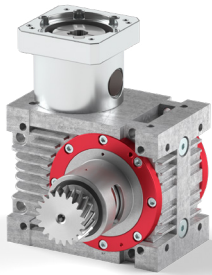

Example HPG 120 C2 Package

Package

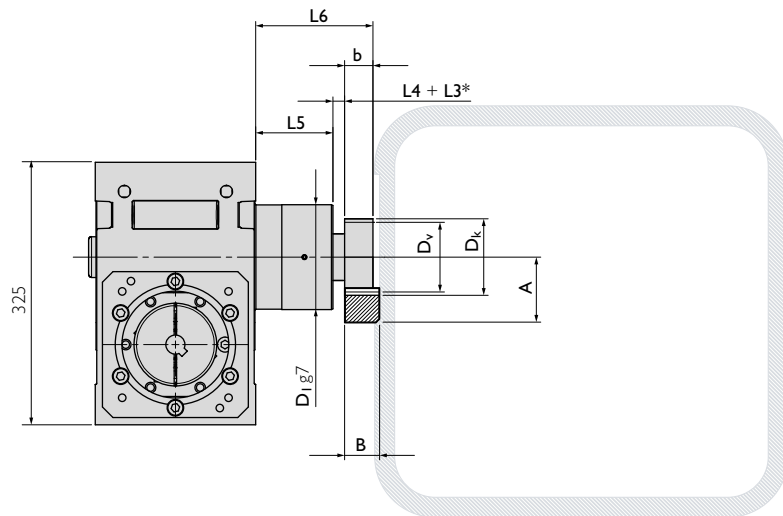

a) The output flange must be supported by the customer supplied equipment at the bearing end (D1), in a hole with an H8 tolerance.

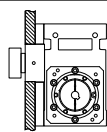

* L3 for additional distance ring.

Geometric information

Helical modular pitch	Part. No.	m_n	P_t	z	A	b	B	D_k	D_0	D_v	D_1	L4	L5	L6
Pinion 1	211521	4	13.33	20	77.44	40	39	92.88	84.883	84.883	180	14.5	123	177.5
Pinion 2	211620	5	16.66	20	87.05	50	49	116.10	106.103	106.103	180	35	123	208.0

m_n : Normal module, P_t : Transverse pitch [mm], z : Number of teeth, D_v : Pitch circle diameter for design, D_0 : Pitch circle diameter for calculation

Straight modular pitch	Part. No.	m_n	P_n	z	A	b	B	D_k	D_0	D_v	D_1	L4	L5	L6
Pinion 3	201620	5	15.71	20	84.0	50	49	110.0	100.000	100.000	180	35	123	208.0
Pinion 4	201720	6	18.85	20	103.0	60	60	132.0	120.000	120.000	180	35	123	218.0
Pinion 5	201820	8	25.13	20	151.0	80	79	176.0	160.000	160.000	180	35	123	238.0

m_n : Normal module, P_n : Normal pitch [mm], z : Number of teeth, D_v : Pitch circle diameter for design, D_0 : Pitch circle diameter for calculation

Spacer elements

With pinion special solutions on request

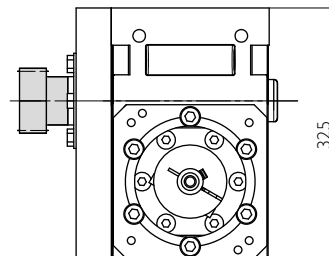
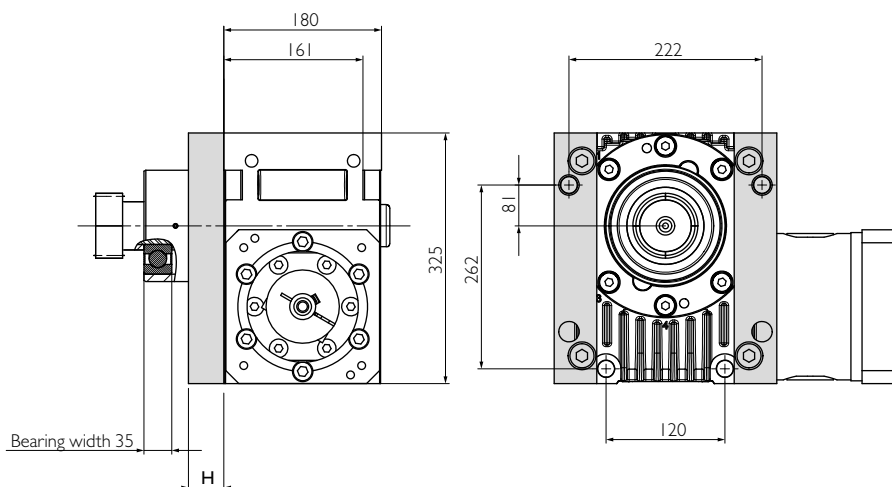

Casing can only be fastened with long screws as per the bore hole pattern.
Screws M6 of length 56mm + H + thread depth, tightening torque 9Nm.

Shrink disc

Elastomer coupling

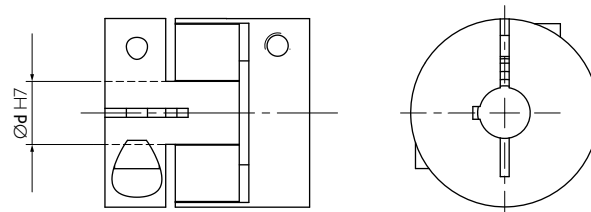
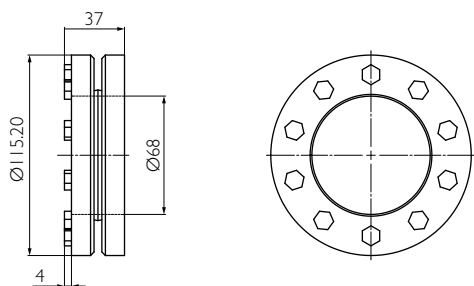

For more details see **Motor Interface** on page 84 et. seq.

Your ideal drive train

Our function package with high-performance angle gearbox, output flange, pinion and rack by Güdel.

			Pinion 1			Pinion 2			Pinion 3	Pinion 4	Pinion 5
			Q6	Q7	Q9	Q6	Q7	Q9	Q6	Q6	Q6
Max acceleration force	F _{2B}	[N]	28585	14084	24045	44505	23785	40048	37317	52880	91220
Max acceleration torque	T _{2B}	[Nm]	1213	598	1021	2361	1262	2125	1866	3173	7298
Precision			PR	PS		PR	PS				
Feed force			High	Medium	Elevated	High	Medium	Elevated			

Above values for rack and pinion take into consideration a number of load cycles: 1x10⁶ for the rack; 1x10⁷ for the pinion. Both in pulsating operation.

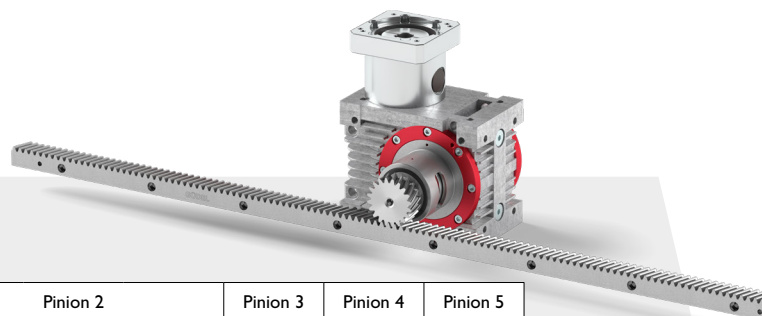

See **rack & pinion program** of your ideal drive train on pages 68 et seq.

See **flowcharts** to find your ideal drive train on pages 86 et seq.

Input

Output

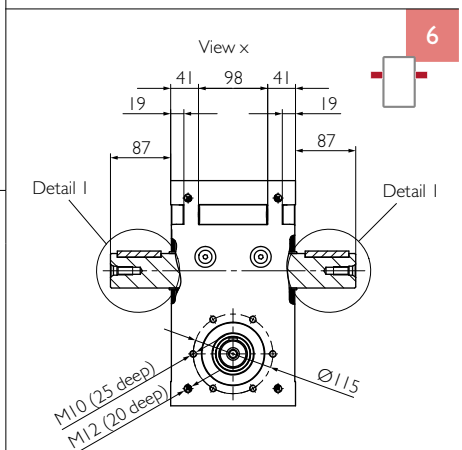
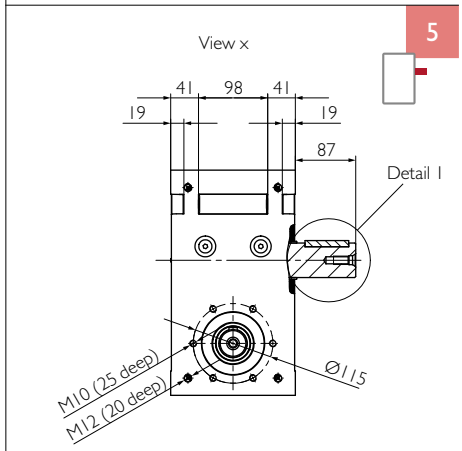
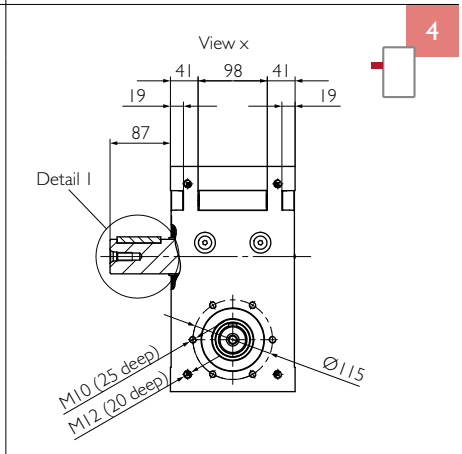
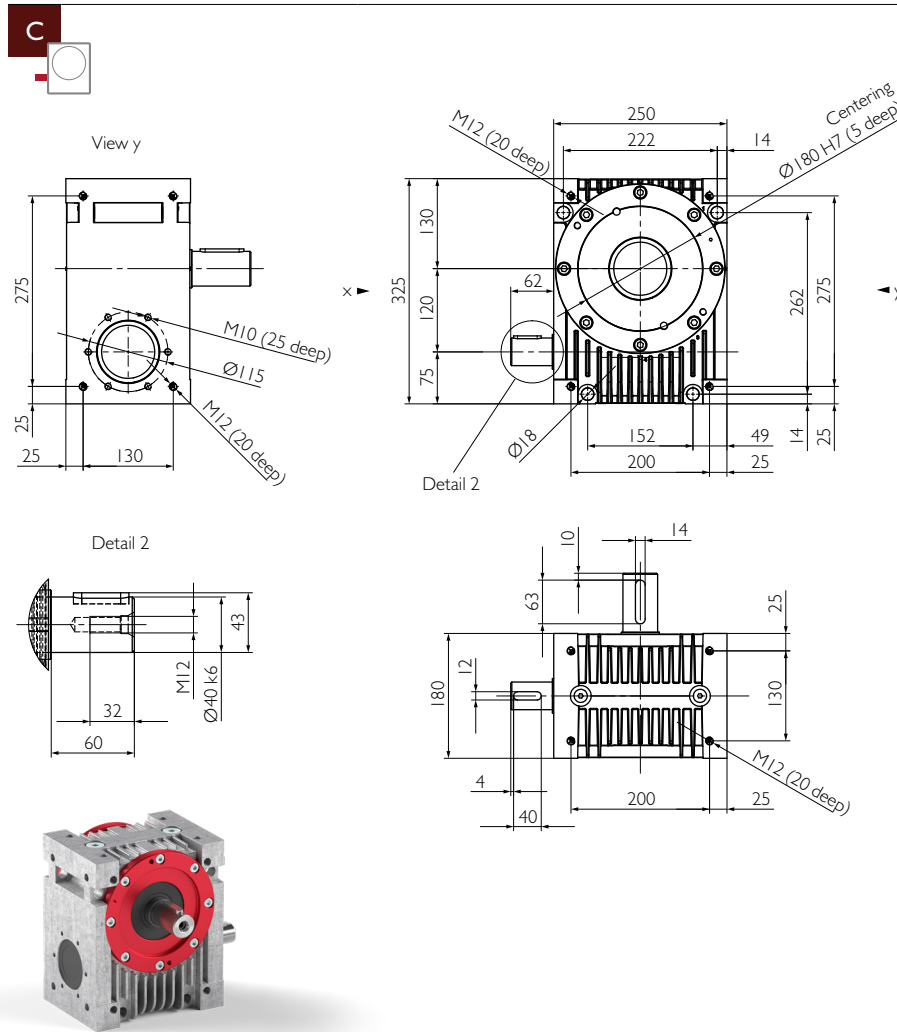

Example HPG 120 C4

C with option motor flange

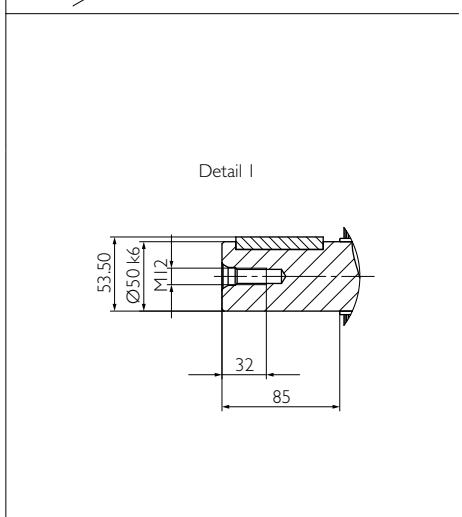
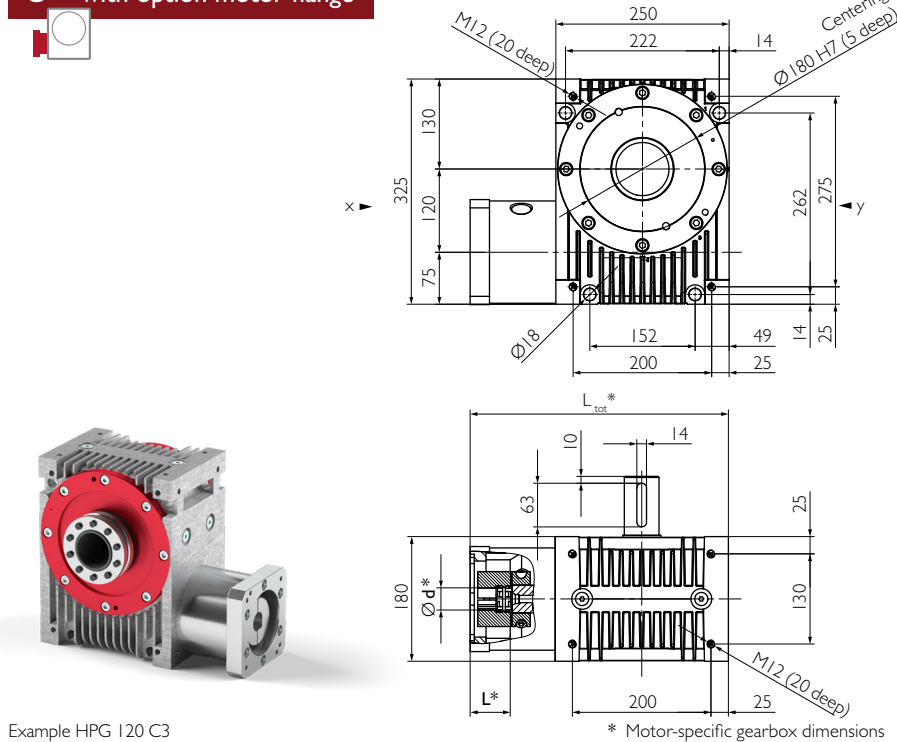

Example HPG 120 C3

* Motor-specific gearbox dimensions

Ratio	i			2	3	4	5	6	8	10	13.33	16	24	30	47	60
Nominal torque at the output Efficiency	n _{1N} = 500rpm	T _{2N}	[Nm]	1177	1732	2018	1969	1752	2038	1895	1863	1824	1900	1364	1970	1364
		η	[%]	93	93	93	93	92	90	89	87	84	78	75	66	61
	n _{1N} = 1000rpm	T _{2N}	[Nm]	836	1284	1534	1523	1371	1609	1505	1487	1658	1622	1364	1612	1364
		η	[%]	94	94	94	93	93	91	90	88	85	80	76	68	62
	n _{1N} = 1500rpm	T _{2N}	[Nm]	648	1020	1237	1241	1126	1329	1248	1237	1380	1353	1364	1345	1364
		η	[%]	94	94	94	93	93	91	90	88	86	80	76	69	62
	n _{1N} = 3000rpm	T _{2N}	[Nm]	387	631	783	798	733	873	826	822	918	903	921	899	921
		η	[%]	93	94	93	93	93	91	90	88	85	80	74	68	60
	n _{1N} = 4500rpm	T _{2N}	[Nm]	276	457	573	588	543	650	617	616	688	677	689	675	689
		η	[%]	93	93	93	93	92	89	87	84	79	73	66	58	
Max. acceleration torque		T _{2B}	[Nm]	1200	2040								1400	2040	1400	
Emergency stop torque		T _{2not}	[Nm]	2300										1600	2300	1600
Idling torque ^{a)}		T ₀₁₂	[Nm]	4.5			4			3						
Max. input speed		n _{1Max}	[rpm]	4500												
Max. backlash ^{b)} at the output	PS	j _t	[arcmin]	<8	<7	<6	<6	<5	<5						<4	
	PR	j _t	[arcmin]	<5.5	<4.5	<4	<3.5	<3	<3						<2.5	
Torsional rigidity from output to input		C _{t21}	[Nm/arcmin]	11.5	19	24.5	26.5	29	31.5	34	36.5	38.5	40.5	39	42.5	39
Stability at the output		C _{2K}	[Nm/arcmin]	138												
Max. axial force ^{c)d)} at the output		F _{a2max}	[N]	2400	3900	3600	6200	9100	10000	13000	16000	17000	18000	18000	19000	19000
Max. radial force ^{c)e)} at the output		F _{r2max}	[N]	2500	2500	2700	3600	6200	6500	7500	8600	8700	9000	9100	9200	9200
Max. overturning torque ^{c)} at the output		M _{2max}	[Nm]	340	340	360	480	830	880	1000	1200	1200	1200	1200	1200	1200
Max. axial force ^{c)d)} at the input		F _{a1max}	[N]	3600	1800	730	1700	3600	2100	3300	3700	2500	2900	2700	3100	2700
Max. radial force ^{c)f)} at the input		F _{r1max}	[N]	1900	950	390	930	1900	1200	1800	2000	1300	1600	1400	1700	1500
Mass moment of inertia ^{g)}		J _I	[10 ⁻⁵ kg m ²]	1392	660	403	285	220	156	127	103	94	83	80	76	75
Mass moment of inertia ^{g)h)}		J _I	[10 ⁻⁵ kg m ²]	1459	726	470	351	287	223	193	170	161	150	146	143	142
Mass moment of inertia ^{g)i)}		J _I	[10 ⁻⁵ kg m ²]	1574	842	585	467	402	338	309	285	276	265	262	258	257
Service life		L _n	[h]	25000												
Weight without motor components		m	[kg]	46												
Weight with motor components		m	[kg]	≈ 51												
Max. permissible housing temperature			[°C]	+90												
Ambient temperature			[°C]	-15 up to +50												
Lubrication				synthetic gear oil (as per DIN 51502: CLP PG 460)												
Painting				None												
Protection class				IP65												

- a) approximate, at n₁ = 3000rpm and operating temperature.
- b) Precision grade PS (standard backlash) for classic mechanical engineering applications.
Precision grade PR (reduced backlash) for precise process applications.
- c) Bearing forces: Values valid at n₁ = 1500rpm; ½ T_{2N} and duty cycle of 40%.
Consult with Güdel for composite bearing forces, axial and radial forces.
- c d) in relation to shaft center.
- c e) at a distance of 135 mm from the middle of the casing.
- c f) at a distance of 160 mm from the middle of the casing.
- g) in relation to the input.
- g) h) including elastomer coupling 5103-38 (calculated with drilled hole for motor shaft-Ø45)
- g) i) including elastomer coupling 5103-42 (calculated with drilled hole for motor shaft-Ø44)

Bearing forces

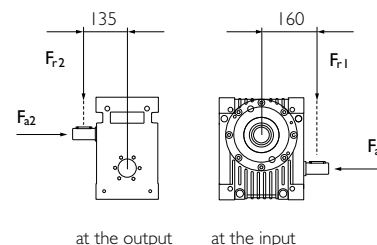

Input

Output

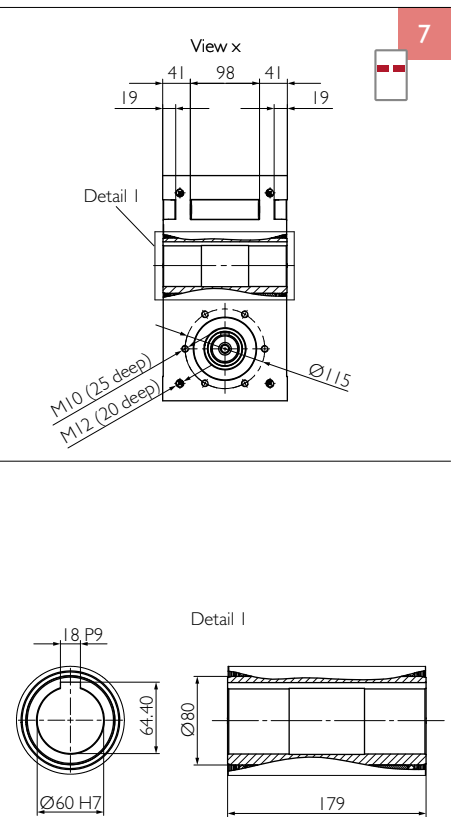
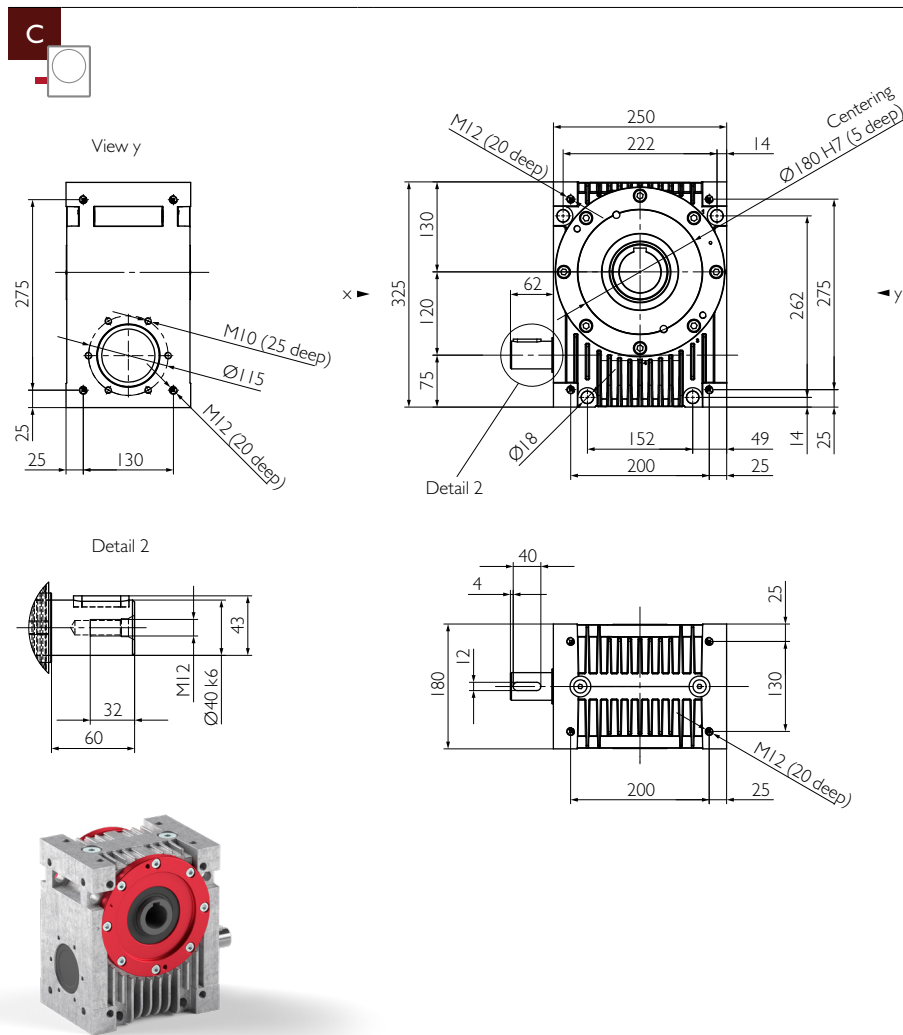

Example HPG 120 C7

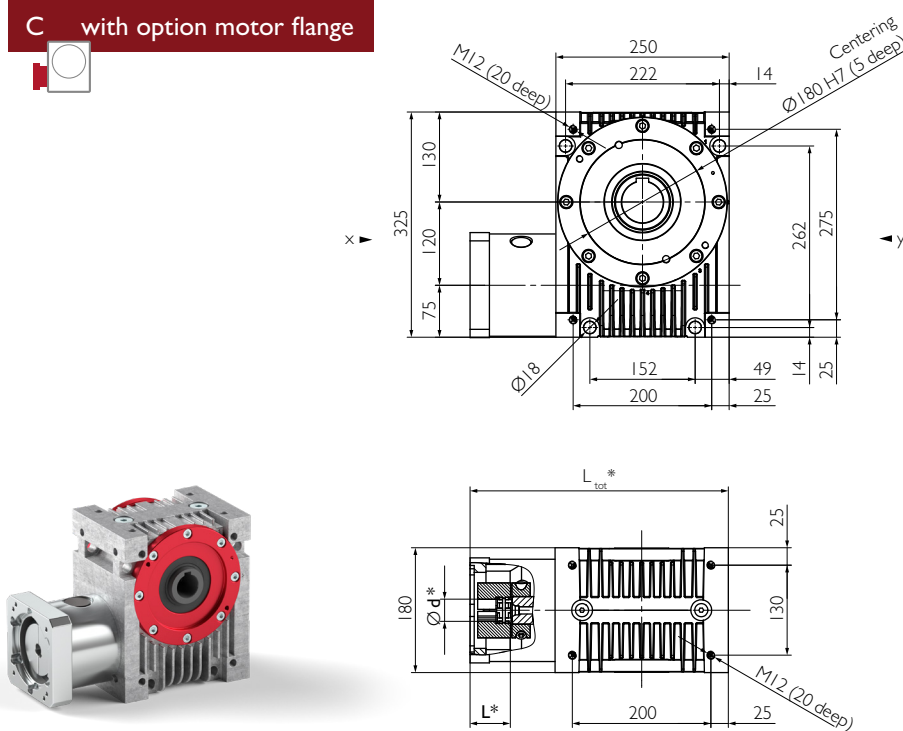

Example HPG 120 C7

* Motor-specific gearbox dimensions

Ratio	i			2	3	4	5	6	8	10	13.33	16	24	30	47	60
Nominal torque at the output Efficiency	n _{1N} = 500rpm	T _{2N}	[Nm]	1177	1732	2018	1969	1752	2038	1895	1863	1824	1900	1364	1970	1364
		η	[%]	93	93	93	93	92	90	89	87	84	78	75	66	61
	n _{1N} = 1000rpm	T _{2N}	[Nm]	836	1284	1534	1523	1371	1609	1505	1487	1658	1622	1364	1612	1364
		η	[%]	94	94	94	93	93	91	90	88	85	80	76	68	62
	n _{1N} = 1500rpm	T _{2N}	[Nm]	648	1020	1237	1241	1126	1329	1248	1237	1380	1353	1364	1345	1364
		η	[%]	94	94	94	93	93	91	90	88	86	80	76	69	62
	n _{1N} = 3000rpm	T _{2N}	[Nm]	387	631	783	798	733	873	826	822	918	903	921	899	921
		η	[%]	93	94	93	93	93	91	90	88	85	80	74	68	60
	n _{1N} = 4500rpm	T _{2N}	[Nm]	276	457	573	588	543	650	617	616	688	677	689	675	689
		η	[%]	93	93	93	93	92	89	87	84	79	73	66	58	
Max. acceleration torque		T _{2B}	[Nm]	1200	2040								1400	2040	1400	
Emergency stop torque		T _{2not}	[Nm]	2300								1600	2300	1600		
Idling torque ^{a)}		T ₀₁₂	[Nm]	4.5			4			3						
Max. input speed		n _{1Max}	[rpm]	4500												
Max. backlash ^{b)} at the output	PS	j _t	[arcmin]	<8	<7	<6	<6	<5	<5						<4	
	PR	j _t	[arcmin]	<5.5	<4.5	<4	<3.5	<3	<3						<2.5	
Torsional rigidity from output to input		C _{t21}	[Nm/arcmin]	11.5	19	24.5	26.5	29	31.5	34	36.5	38.5	40.5	39	42.5	39
Stability at the output		C _{2K}	[Nm/arcmin]	165												
Max. axial force ^{c)d)} at the output		F _{a2max}	[N]	7000	9600	9500	12000	16000	17000	21000	25000	26000	27000	27000	27000	28000
Max. radial force ^{c)e)} at the output		F _{r2max}	[N]	7700	8100	7300	8800	9900	10000	12000	13000	13000	14000	14000	14000	14000
Max. overturning torque ^{c)} at the output		M _{2max}	[Nm]	1000	1100	980	1200	1300	1400	1600	1800	1800	1800	1800	1900	1900
Max. axial force ^{c)d)} at the input		F _{a1max}	[N]	3600	1800	730	1700	3600	2100	3300	3700	2500	2900	2700	3100	2700
Max. radial force ^{c)f)} at the input		F _{r1max}	[N]	1900	950	390	930	1900	1200	1800	2000	1300	1600	1400	1700	1500
Mass moment of inertia ^{g)}		J ₁	[10 ⁻⁵ kg m ²]	1307	622	382	271	211	151	123	102	93	82	79	76	75
Mass moment of inertia ^{g)h)}		J ₁	[10 ⁻⁵ kg m ²]	1373	688	449	338	277	217	190	168	160	149	146	143	142
Mass moment of inertia ^{g)i)}		J ₁	[10 ⁻⁵ kg m ²]	1489	804	564	453	393	333	305	284	275	264	261	258	257
Service life		L _n	[h]	25000												
Weight without motor components		m	[kg]	46												
Weight with motor components		m	[kg]	≈ 51												
Max. permissible housing temperature			[°C]	+90												
Ambient temperature			[°C]	-15 up to +50												
Lubrication				synthetic gear oil (as per DIN 51502: CLP PG 460)												
Painting				None												
Protection class				IP65												

- a) approximate, at n₁ = 3000rpm and operating temperature.
- b) Precision grade PS (standard backlash) for classic mechanical engineering applications.
Precision grade PR (reduced backlash) for precise process applications.
- c) Bearing forces: Values valid at n₁ = 1500rpm; ½ T_{2N} and duty cycle of 40%.
Consult with Güdel for composite bearing forces, axial and radial forces.
- c) d) in relation to shaft center.
- c) e) at a distance of 135 mm from the middle of the casing.
- c) f) at a distance of 160 mm from the middle of the casing.
- g) in relation to the input.
- g) h) including elastomer coupling 5103-38 (calculated with drilled hole for motor shaft-Ø45)
- g) i) including elastomer coupling 5103-42 (calculated with drilled hole for motor shaft-Ø44)

Bearing forces

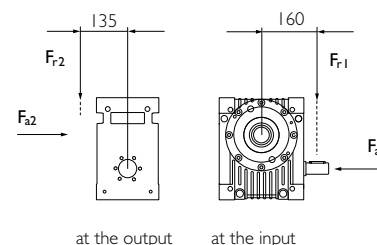

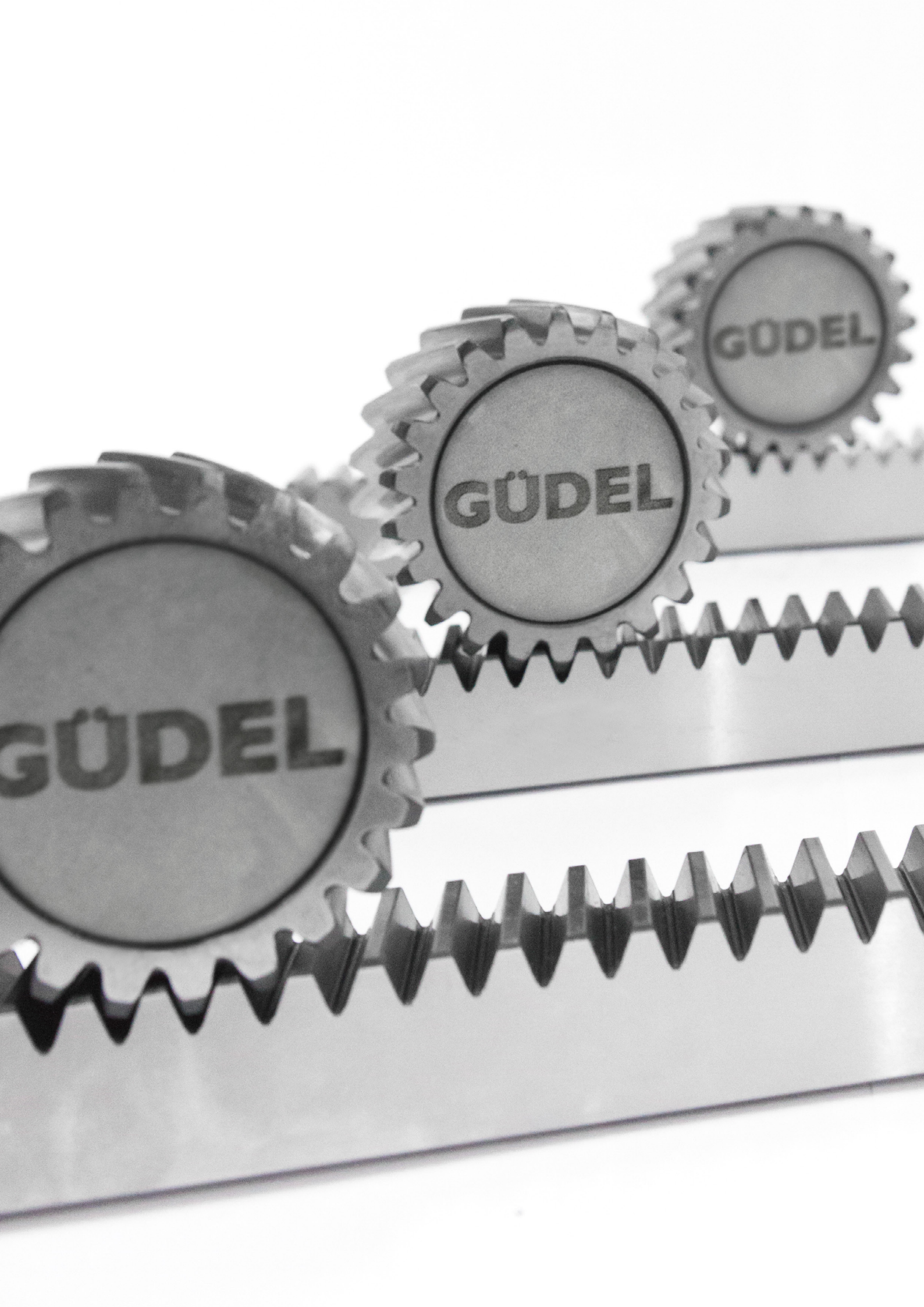
A black and white photograph of three interlocking gears. The gears are arranged in a diagonal line from the bottom left towards the top right. Each gear has the word "GÜDEL" printed in a bold, sans-serif font in the center of its face. The gears are interlocked, with the teeth of one gear meshing with the teeth of the adjacent gear. The background is a plain, light color, and the lighting creates soft shadows and highlights on the metallic surfaces of the gears.

GÜDEL

GÜDEL

GÜDEL

Your ideal drive train

GÜDEL

Rack & pinion program

Our function package for your ideal drive train with gearbox, rack and pinion from Güdel.

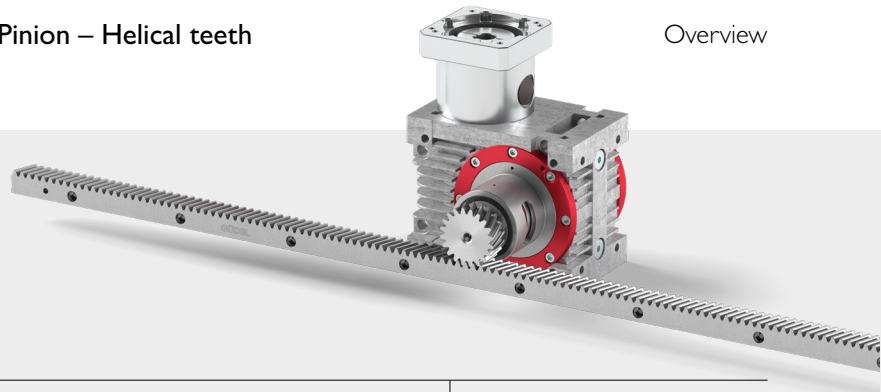

Pinion

Helical teeth, modular pitch



Hardened and ground

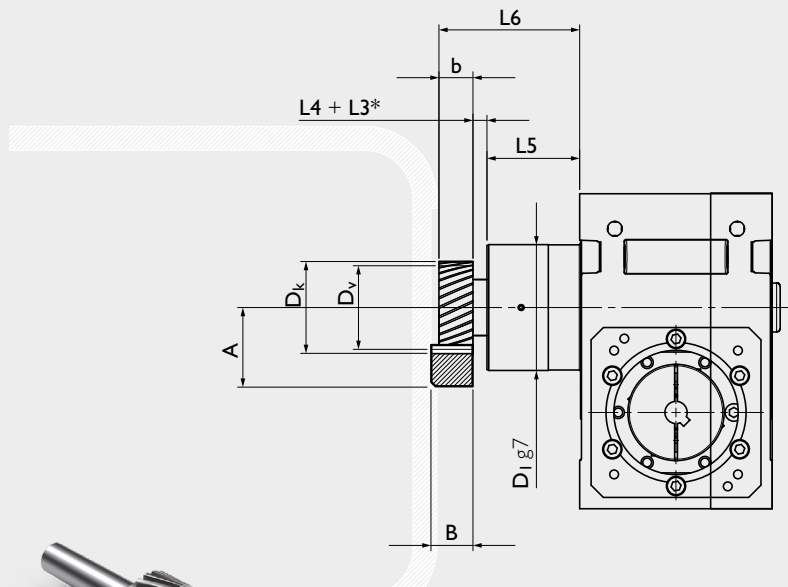

Material
16MnCr5 DIN 1.7131
shaft / bore soft

Teeth
pressure angle $\alpha = 20^\circ$
helical tooth system left
helix angle $\beta = 19^\circ 31'42''$
hardened (58^{+4}_0 HRC)
ground, crowned

Quality
6f24 DIN 3962/63/67

Geometrical data

Size	m_n	P_t	z	A	b	D_k	D_0	D_v	L4	L5	L6	M	Part. Nr.
030	1.5	5.00	16	30.680	20	29.36	25.465	26.365	4.5	38	62.5	0.14	211116
										43	67.5		
045	1.5	5.00	20	33.415	20	34.83	31.831	31.831	4.5	43	67.5	0.34	211120
										53	77.5		
	2	6.66	16	39.575		39.15	33.953	35.153	8.0	43	71.0	0.39	211216
										53	81.0		
060	2	6.66	20	43.220	20	46.44	42.441	42.441	8.0	53	81.0	0.70	211220
										58	86.0		
										83	111.0		
	2.5	8.33	20	48.025	25	58.05	53.052	53.052	8.0	53	86.0	0.91	211320
										58	91.0		
										83	116.0		
3	10.00	16	52.365	30	58.73	50.930	52.730	8.0	53	91.0	0.99	211416	
									58	96.0			
									83	121.0			
090	3	10.00	20	57.830	30	69.66	63.662	63.662	12.5	63	105.5	2.38	211420
										104.5	147.0		
	4	13.33	77.440	40	92.88	84.883	84.883	18.0	63	121.0	3.43	211520	
120	4	13.33	20	77.440	40	92.88	84.883	84.883	14.5	123	177.5	7.89	211521
	5	16.66		87.050	50	116.10	106.103	106.103	35.0	123	208.0	9.96	211620

m_n : Normal module, P_t : Transverse pitch [mm], z : Number of teeth, D_0 : Pitch circle diameter for calculation, D_v : Pitch circle diameter for design, M: Weight [kg]

*L3 for additional distance ring

Rack

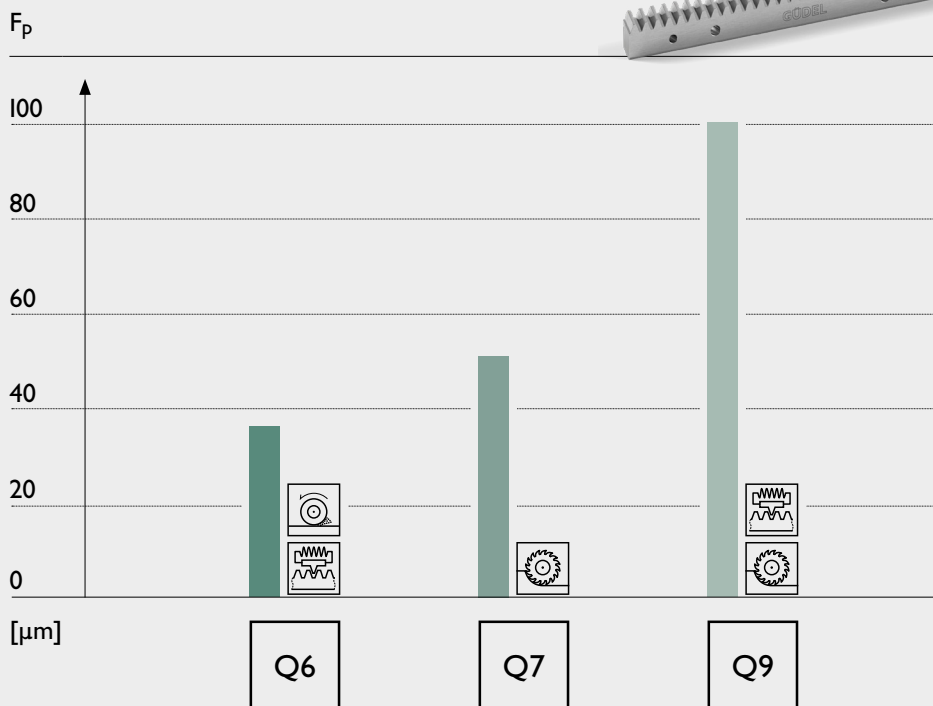
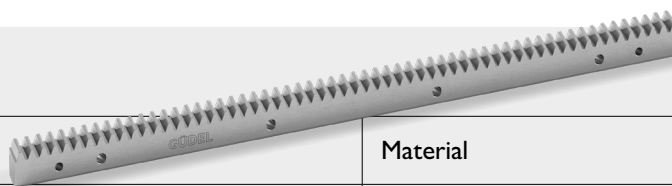

Material



Steel

Processes



Hardened



Milled



Ground



Helical teeth

Example of the cumulative pitch deviation F_p for module 4 based on length 1000mm. Quality DIN 3962.

Geometrical data

Size	m_n	P_t	L	z	b	h
030 045	1.5	5.00	500.00	100	19	19
			1000.00	200		
045 060	2	6.66	500.00	75	24	24
			1000.00	150		
			2000.00	300		
060	2.5	8.33	500.00	60	24	24
			1000.00	120		
			2000.00	240		
060 090	3	10.00	500.00	50	29	29
			1000.00	100		
			2000.00	200		
090 120	4	13.33	506.67	38	39	39
			1000.00	75		
			2000.00	150		
120	5	16.66	500.00	30	49	39
			1000.00	60		
			2000.00	120		

m_n : Normal module, P_t : Transverse pitch [mm], z: Number of teeth

Q6		Q7		Q9	
Part No.	Part No.	Part No.	Part No.	Part No.	Part No.
246012	155012	158012			
246013	155013	158013			
246022	155022	158022			
246023	155023	158023			
246024	155024	158024			
246032	155032	158032			
246033	155033	158033			
246034	155034	158034			
246042	155042	158042			
246043	155043	158043			
246044	155044	158044			
246055	155052	158052			
246056	155053	158053			
246057	155054	158054			
246062	155062	158062			
246063	155063	158063			
246064	155064	158064			

Page 70

Page 71

Page 72



Helical teeth, modular pitch



Hardened and ground

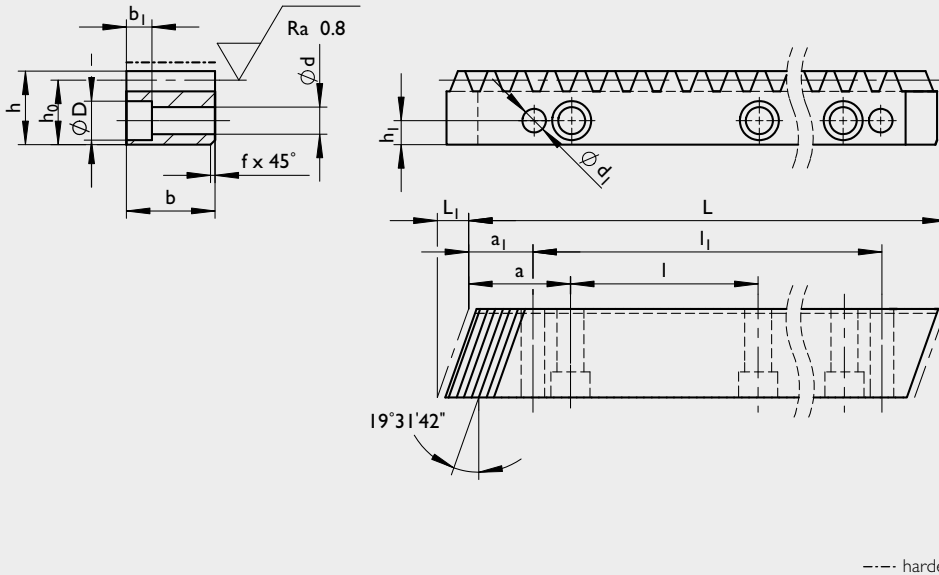

Material
C45E DIN 1.1191

Profile
all faces ground

Teeth
pressure angle $\alpha = 20^\circ$
helical tooth system right
helix angle $\beta = 19^\circ 31' 42''$
hardened (54^{+4} HRC)
and ground

Quality
6h23 DIN 3962/63/67

p_f [mm]
cut-to-length tolerance for
continuous mounting $-0.05/-0.50$

F_{pL} [mm]
cumulative pitch deviation
based on length L

--- hardened



Geometrical data

Size	m_n	p_t	L	L_1	z	b	h	h_0	f+0.5	a	l	h_1	d	D	b_1	a_1	l_1	d_1	F_{pL}	M	Part. No.
030 045	1.5	5	500	6.7	100	19	19	17.50	2	62.5	125.00	8	7	11	7	31.7	436.6	5.7	0.029	1.3	246012
			1000		200														0.043	2.6	246013
045 060	2	6.66	500	8.5	75	24	24	22.00	2	62.5	125.00	8	7	11	7	31.7	436.6	5.7	0.025	2.1	246022
			1000		150														0.036	4.1	246023
			2000		300														0.058	8.2	246024
060	2.5	8.33	500	8.5	60	24	24	21.50	2	62.5	125.00	9	7	11	7	31.7	436.6	5.7	0.027	2.0	246032
			1000		120														0.036	4.1	246033
			2000		240														0.053	8.2	246034
060 090	3	10.00	500	10.3	50	29	29	26.00	2	62.5	125.00	9	10	15	9	35.0	430.0	7.7	0.028	3.0	246042
			1000		100														0.037	5.9	246043
			2000		200														0.054	11.2	246044
090 120	4	13.33	506.67	13.8	38	39	39	35.00	2	62.5	125.00	12	12	18	11	33.3	433.0	9.7	0.030	5.4	246055
			1000		75														0.036	10.7	246056
			2000		150														0.050	20.5	246057
120	5	16.66	500	17.4	30	49	39	34.00	3	62.5	125.00	12	14	20	13	37.5	425.0	11.7	0.028	6.5	246062
			1000		60														0.034	13.1	246063
			2000		120														0.045	24.5	246064

m_n : Normal module, P_t : Transverse pitch [mm], z: number of teeth, d_1 : predrilled, M: Weight [kg]

Rack – Helical teeth

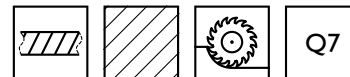

Helical teeth, modular pitch



Milled

Material
42CrMo4 DIN 1.7225 I

Profile
all faces milled

Teeth
pressure angle $\alpha = 20^\circ$
helical tooth system right
helix angle $\beta = 19^\circ 31'42''$
milled

Quality
7h25 DIN 3962/63/67

p_f [mm]
cut-to-length tolerance for
continuous mounting -0.05/-0.50

F_{pL} [mm]
cumulative pitch deviation
based on length L

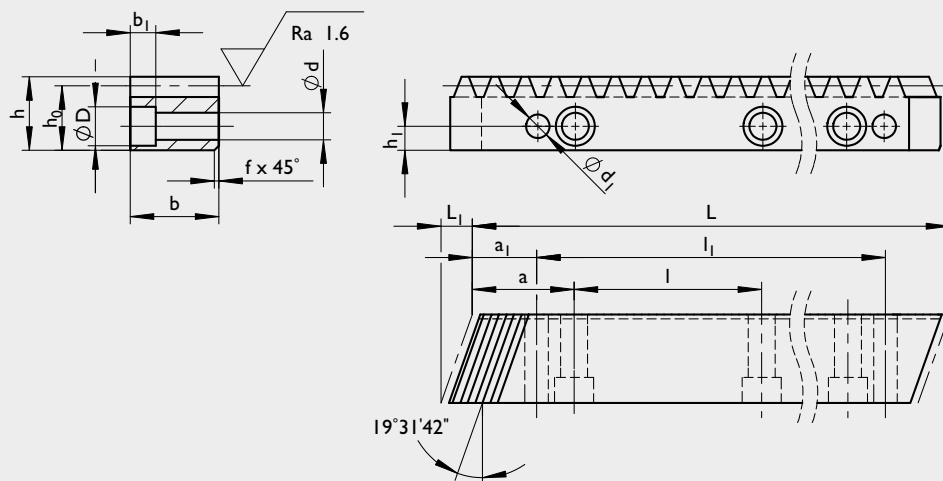

Geometrical data

Size	m _n	P _t	L	L ₁	z	b	h	h ₀	f+0.5	a	l	h ₁	d	D	b ₁	a ₁	l ₁	d ₁	F _{pL}	M	Part. No.
030 045	1.5	5.00	500.00	6.7	100	19	19	17.5	1	62.5	125	8	7	11	7	31.7	436.6	5.7	0.041	1.2	155012
			1000.00		200														0.059	2.5	155013
045 060	2	6.66	500.00	8.5	75	24	24	22.0	1	62.5	125	8	7	11	7	31.7	436.6	5.7	0.036	2.0	155022
			1000.00		150														0.050	4.0	155023
			2000.00		300														0.077	8.0	155024
060	2.5	8.33	500.00	8.5	60	24	24	21.5	1	62.5	125	9	7	11	7	31.7	436.6	5.7	0.038	1.9	155032
			1000.00		120														0.050	3.9	155033
			2000.00		240														0.075	7.7	155034
060 090	3	10.00	500.00	10.3	50	29	29	26.0	1	62.5	125	9	10	15	9	35.0	430.0	7.7	0.040	2.8	155042
			1000.00		100														0.051	5.6	155043
			2000.00		200														0.073	11.2	155044
090 120	4	13.33	506.67	13.8	38	39	39	35.0	1	62.5	125	12	12	18	11	33.3	433.0	9.7	0.042	5.1	155052
			1000.00		75														0.051	10.1	155053
			2000.00		150														0.070	20.2	155054
120	5	16.66	500.00	17.4	30	49	39	34.0	1	62.5	125	12	14	20	13	37.5	425.0	11.7	0.040	6.0	155062
			1000.00		60														0.048	12.0	155063
			2000.00		120														0.062	24.1	155064

m_n: Normal module, P_t: Transverse pitch [mm], z: number of teeth, d₁: predrilled, M: Weight [kg]



Module

Rack – Helical teeth

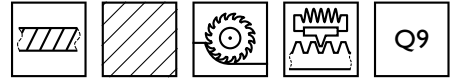

Helical teeth, modular pitch



Milled and hardened

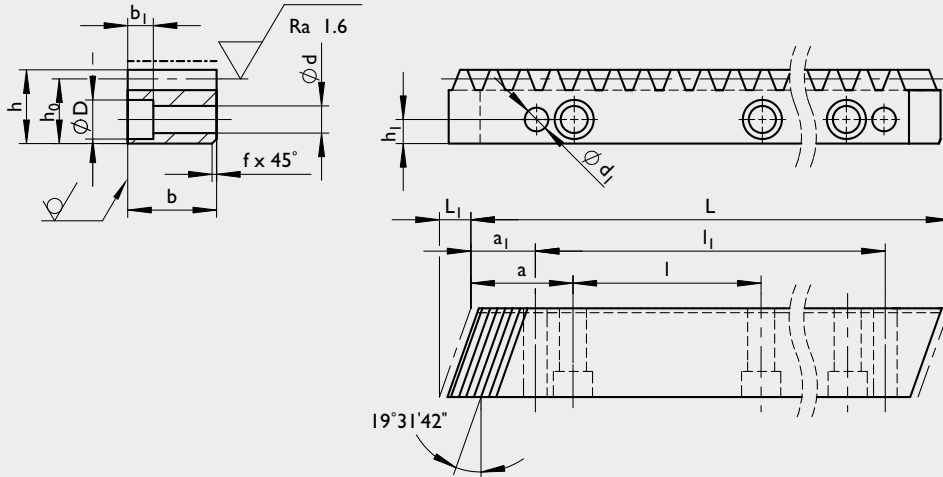

--- hardened

Material
C45E DIN 1.1191

Profile
all faces milled

Teeth
pressure angle $\alpha = 20^\circ$
helical tooth system right
helix angle $\beta = 19^\circ 31' 42''$
hardened (54⁺⁴HRC)
milled

Quality
9h27 DIN 3962/63/67

p_f [mm]
cut-to-length tolerance for
continuous mounting -0.05/-0.50

F_{pL} [mm]
cumulative pitch deviation
based on length L



Geometrical data

Size	m _n	p _t	L	L _i	z	b	h	h ₀	f+0.5	a	l	h ₁	d	D	b ₁	a ₁	l ₁	d ₁	F _{pL}	M	Part. No.
030 045	1.5	5.00	500.00	6.7	100	19	19	17.50	2	62.5	125.00	8	7	11	7	31.7	436.6	5.7	0.082	1.2	158012
			1000.00		200														0.118	2.5	158013
045 060	2	6.66	500.00	8.5	75	24	24	22.00	2	62.5	125.00	8	7	11	7	31.7	436.6	5.7	0.073	2.0	158022
			1000.00		150														0.100	4.0	158023
			2000.00		300														0.155	8.0	158024
060	2.5	8.33	500.00	8.5	60	24	24	21.50	2	62.5	125.00	9	7	11	7	31.7	436.6	5.7	0.076	1.9	158032
			1000.00		120														0.101	3.9	158033
			2000.00		240														0.150	7.7	158034
060 090	3	10.00	500.00	10.3	50	29	29	26.00	2	62.5	125.00	9	10	15	9	35.0	430.0	7.7	0.080	2.8	158042
			1000.00		100														0.103	5.6	158043
			2000.00		200														0.147	11.2	158044
090 120	4	13.33	506.67	13.8	38	39	39	35.00	3	62.5	125.00	12	12	18	11	33.3	433.0	9.7	0.083	5.1	158052
			1000.00		75														0.101	10.1	158053
			2000.00		150														0.136	20.2	158054
120	5	16.66	500.00	17.4	30	49	39	34.00	3	62.5	125.00	12	14	20	13	37.5	425.0	11.7	0.080	6.0	158062
			1000.00		60														0.094	12.0	158063
			2000.00		120														0.122	24.1	158064

m_n: Normal module, P_t: Transverse pitch [mm], z: number of teeth, d₁: predrilled, M: Weight [kg]



Rack & pinion program

Our function package for your ideal drive train with gearbox, rack and pinion from Güdel.

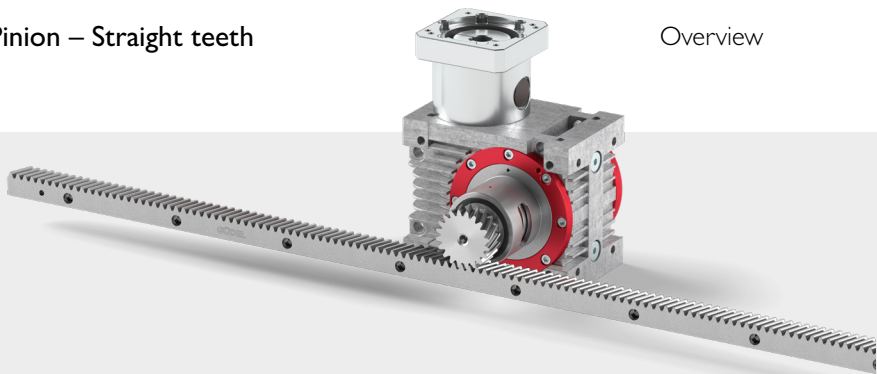

Pinion

Straight teeth, modular pitch



Hardened and ground

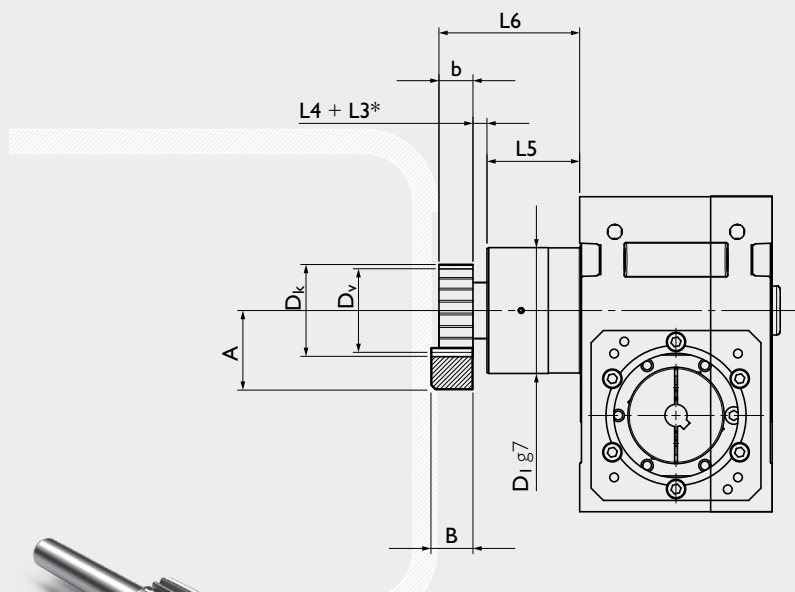

Material
16MnCr5 DIN 1.7131
shaft/bore soft

Teeth
pressure angle $\alpha = 20^\circ$
straight teeth
hardened (58⁺¹/₀ HRC)
ground, crowned

Quality
6f24 DIN 3962/63/67

Geometrical data

Size	m_n	P_n	z	A	b	D_k	D_0	D_v	L4	L5	L6	M	Part. No.
030	1.5	4.72	16	29.95	20	27.90	24.000	24.900	4.5	38.0	82.5	0.14	201116
										43.0	67.5		
045	1.5	4.72	20	32.50	20	33.00	30.000	30.000	4.5	43.0	67.5	0.34	201120
										53.0	77.5		
	2	6.28	16	38.60	20	37.20	32.000	33.200	8.0	43.0	71.0	0.37	201216
										53.0	81.0		
	2	6.28	20	42.00	20	44.00	40.000	40.000	8.0	53.0	81.0	0.68	201220
										58.0	86.0		
060	2.5	7.85	20	46.00	25	55.00	50.000	50.000	8.0	83.0	111.0	0.86	201320
										53.0	86.0		
	3	9.42	16	50.90	30	55.80	48.000	49.800	12.5	58.0	91.0	0.93	201416
										83.0	116.0		
090	3	9.42	20	56.00	30	66.00	60.000	60.000	12.5	53.0	91.0	2.30	201420
										58.0	96.0		
	4	12.57	20	75.00	40	88.00	80.000	80.000	18.0	63.0	105.5	3.24	201520
										104.5	147.0		
	5	15.71	20	84.00	50	110.00	100.000	100.000	35.0	63.0	121.0	9.57	201620
										104.5	162.5		
120	6	18.85	20	103.00	60	132.00	120.000	120.000	35.0	208.0	218.0	11.8	201720
										238.0	283.1		
	8	25.13	20	151.00	80	176.00	160.000	160.000				28.31	201820

m_n : Normal module, P_n : Normal pitch, z : Number of teeth, D_0 : Pitch circle diameter for calculation, D_v : Pitch circle diameter for design, M: Weight [kg]

*L3 for additional distance ring

Rack

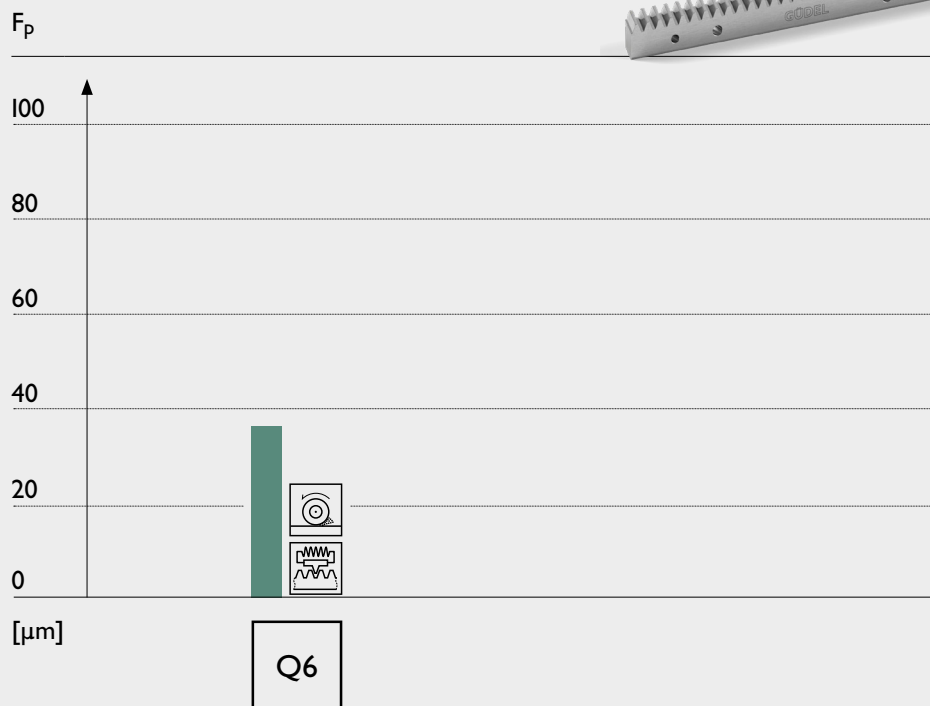
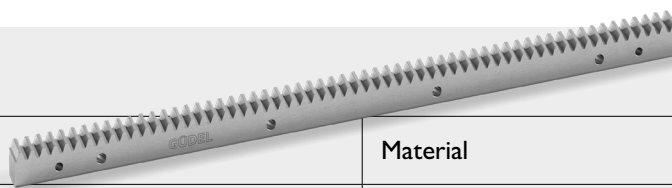

Material



Steel

Processes



Hardened



Ground



Straight teeth

Example of the cumulative pitch deviation F_p for module 4 based on length 1000mm. Quality DIN 3962.

Geometrical data

Size	m_n	P_n	L	z	b	h
030 045	1.5	4.72	499.51	106	19	19
			999.03	212		
045 060	2	6.28	502.65	80	24	24
			1005.31	160		
			2010.62	320		
060	2.5	7.85	502.65	64	24	24
			1005.31	128		
			2010.62	256		
060 090	3	9.42	508.94	54	29	29
			1017.88	108		
			2035.75	216		
90	4	12.57	502.65	40	39	39
			1005.31	80		
			2010.62	160		
120	5	15.71	502.65	32	49	39
			1005.31	64		
			2010.62	128		

m_n : Normal module, P_n : Normal pitch [mm], z: Number of teeth

Q6	
Part. Nr.	
240012	
240013	
240022	
240023	
240024	
240032	
240033	
240034	
240042	
240043	
240044	
240052	
240053	
240054	
240062	
240063	
240064	

Page 76



Module

Rack – Straight teeth

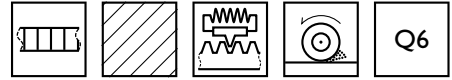

Straight teeth, modular pitch



Hardened and ground

Material
C45E DIN 1.1191
On request: 1.7131 (16MnCr5)

Profile
all faces ground

Teeth
pressure angle $\alpha = 20^\circ$
hardened (54^{+4} HRC)
and ground

Quality
6h23 DIN 3962/63/67

pf [mm]
cut-to-length tolerance for
continuous mounting $-0.05/-0.50$

F_{pl} [mm]
cumulative pitch deviation
based on length L

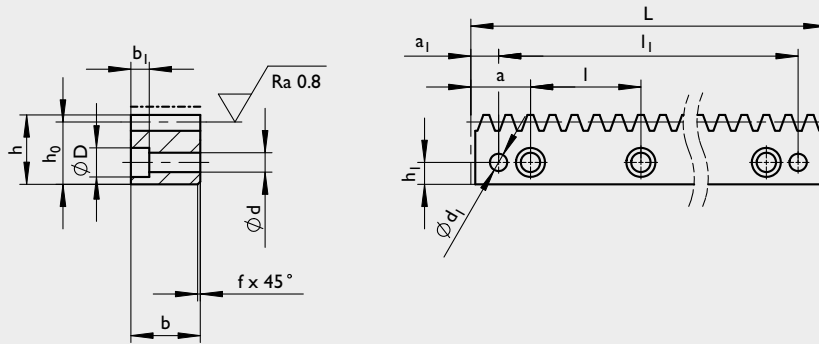

--- hardened



Geometrical data

Size	m _n	p _n	L	z	B	H	H ₀	f+0,5	a	l	h ₁	d	D	b ₁	a ₁	l ₁	d ₁	F _{pl}	M	Part No.
030 045	1.5	4.712	499.51	106	19	19	17.50	2	62.44	124.88	8	7	11	7	29	441.5	5.7	0.029	1.3	240012
			999.03	212												0.043		2.6	240013	
045 060	2	6.283	502.65	80	24	24	22.00	2	62.83	125.66	8	7	11	7	31.3	440.1	5.7	0.025	2.1	240022
			1005.31	160												0.036		4.2	240023	
			2010.62	320												0.058		8.0	240024	
060	2.5	7.854	502.65	64	24	24	21.50	2	62.83	125.66	9	7	11	7	31.3	440.1	5.7	0.027	2.0	240032
			1005.31	128												0.036		4.1	240033	
			2010.62	256												0.053		8.0	240034	
060 090	3	9.425	508.94	54	29	29	26.00	2	63.62	127.23	9	10	15	9	34.4	440.1	7.7	0.029	3.0	240042
			1017.88	108												0.037		6.0	240043	
			2035.75	216												0.055		11.5	240044	
090	4	12.566	502.65	40	39	39	35.00	2	62.83	125.66	12	10	15	9	37.5	427.7	7.7	0.030	5.40	240052
			1005.31	80												0.037		10.8	240053	
			2010.62	160												0.050		21.0	240054	
120	5	15.708	502.65	32	49	39	34.00	3	62.83	125.66	12	14	20	13	30.2	442.3	11.7	0.028	6.6	240062
			1005.31	64												0.034		13.1	240063	
			2010.62	128												0.045		24.7	240064	
120	6	18.850	508.94	27	59	49	43.00	3	63.62	127.23	16	18	26	17	31.4	446.1	15.7	0.031	10.1	240072
			1017.88	54												0.036		20.3	240073	
			2035.75	108												0.047		37.5	240074	
120	8	25.133	502.65	20	79	79	71.00	3	62.83	125.66	25	22	33	21	26.7	449.3	19.7	0.029	22.1	240082
			1005.31	40												0.033		44.3	240083	
			2010.62	80												0.041		82.5	240084	

m_n: Normal module, P_n: Normal pitch [mm], z: number of teeth, d₁: predrilled, M: Weight [kg]

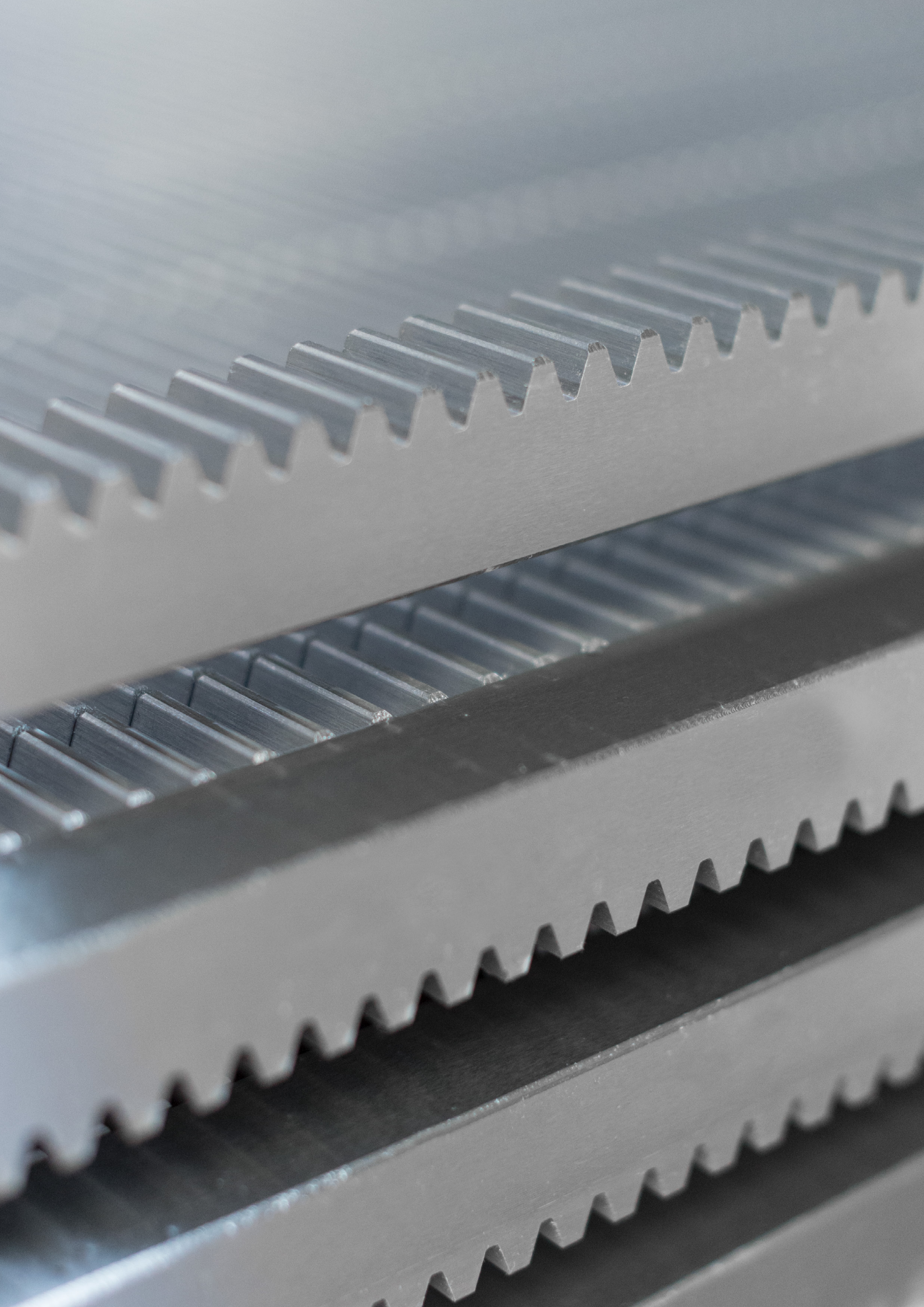

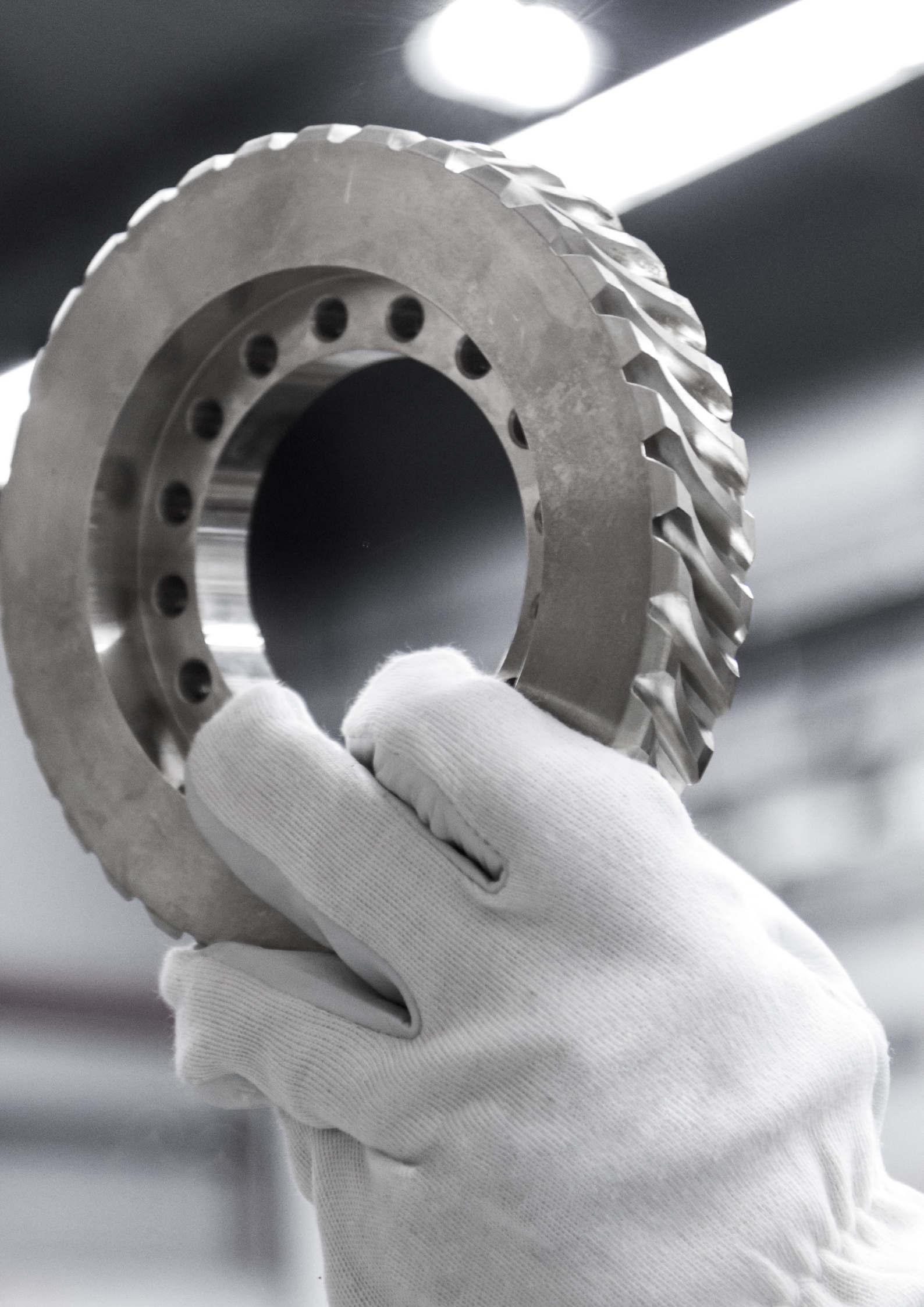

Technical information

GÜDEL

Generate the code of your gearbox

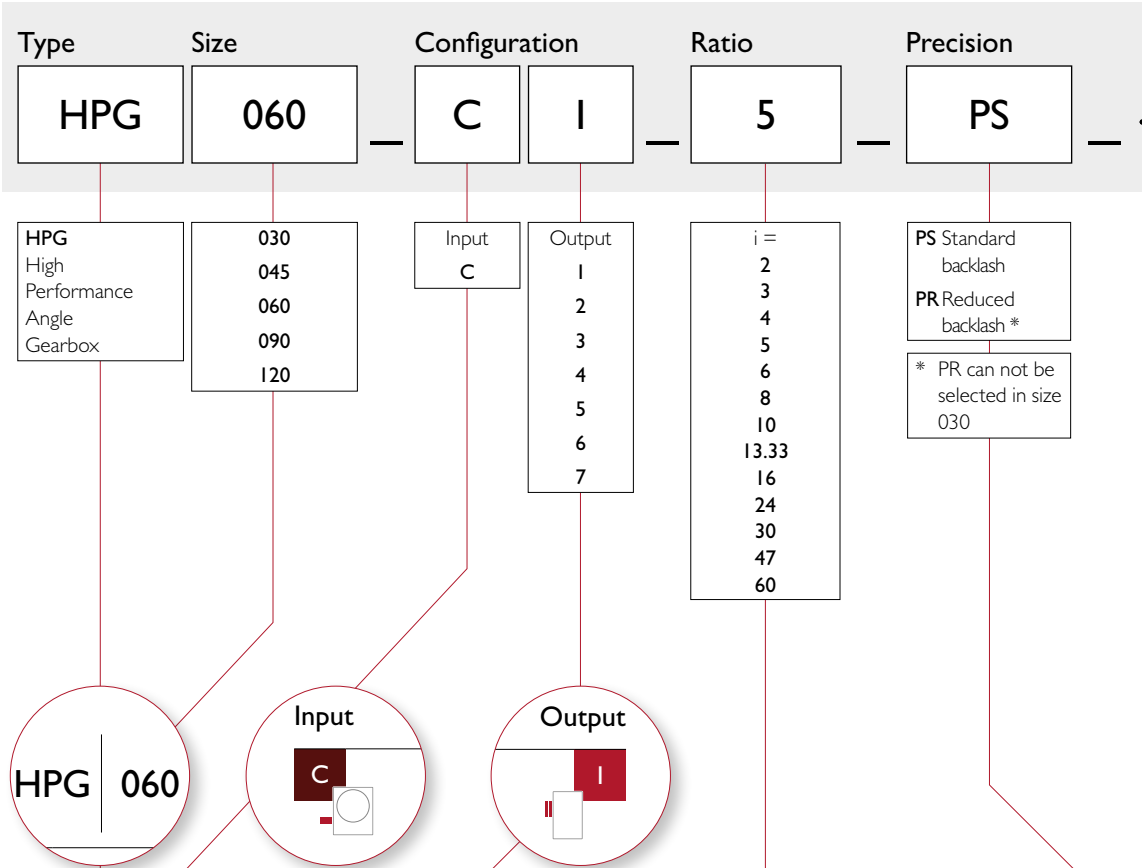

Güdel pinion
211320

Part. No. acc. to catalog

Example HPG 060 C I 5 PS

The output flange can be supplied with the standard bearing and pinion or with an oil seal.

* 12 for additional distance ring

Input/Output pair	Pinion No.	Shaft No.	A	B	h
Phase 1	211320	25	831	20	40.000
Phase 2	211320	25	831	20	40.000
Phase 3	211320	25	831	20	40.000
Phase 4	211320	25	831	20	40.000
Phase 5	211320	25	831	20	40.000
Phase 6	211320	25	831	20	40.000

Pinion No. 211320, Shaft No. 25, A=831, B=20, h=40.000

Unless a pinion is required

HPG 060 High performance angle gearboxes

Technical drawings showing various views of the gearbox (front, side, rear, and detail views).

Technical data sheets with tables for dimensions, weights, and performance parameters.

Package information table:

Configuration	Weight (kg)	Dimensions (mm)
C I 5 PS	12.5	140 x 140 x 140

See technical data sheets on pages 26 et seq.

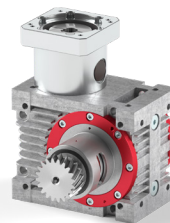
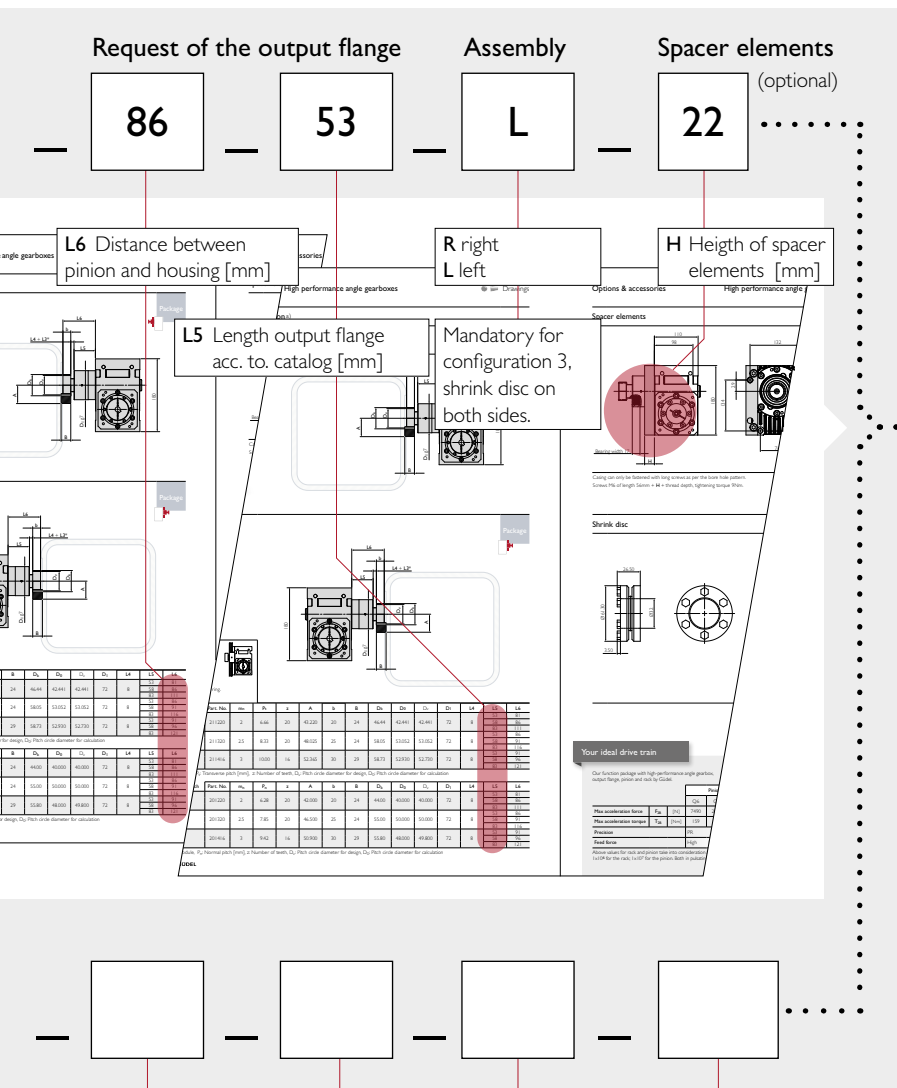

Example
HPG060_CI_5_PS_21|320_86_53_22

Motor

Unless a package is required
(Output flange including bearing & pinion)

Unless spacer elements are required

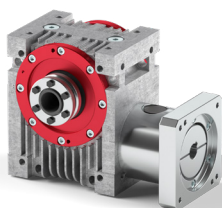

Example
HPG060_CI_5_PS

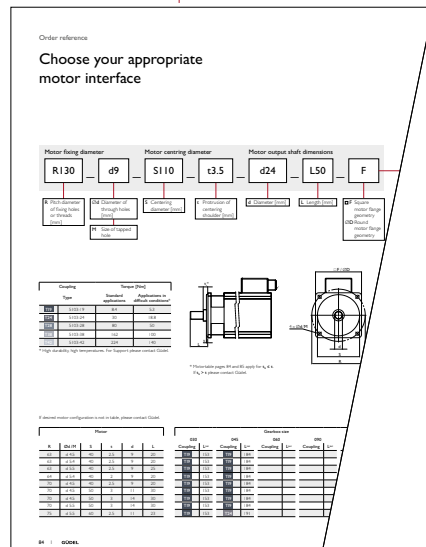

See order reference
of the motor interfaces
on pages 82 et seq.

Choose your appropriate motor interface

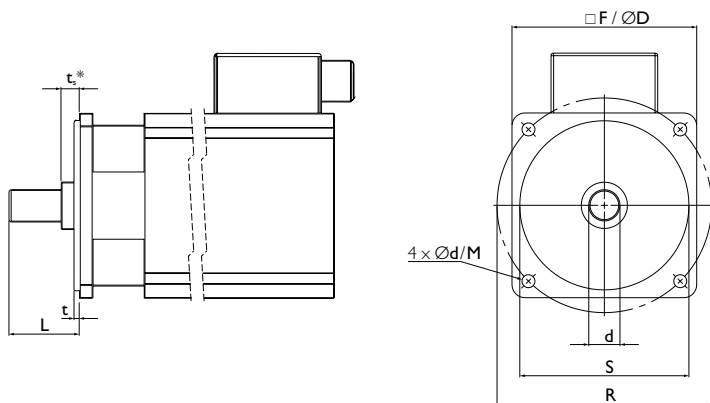
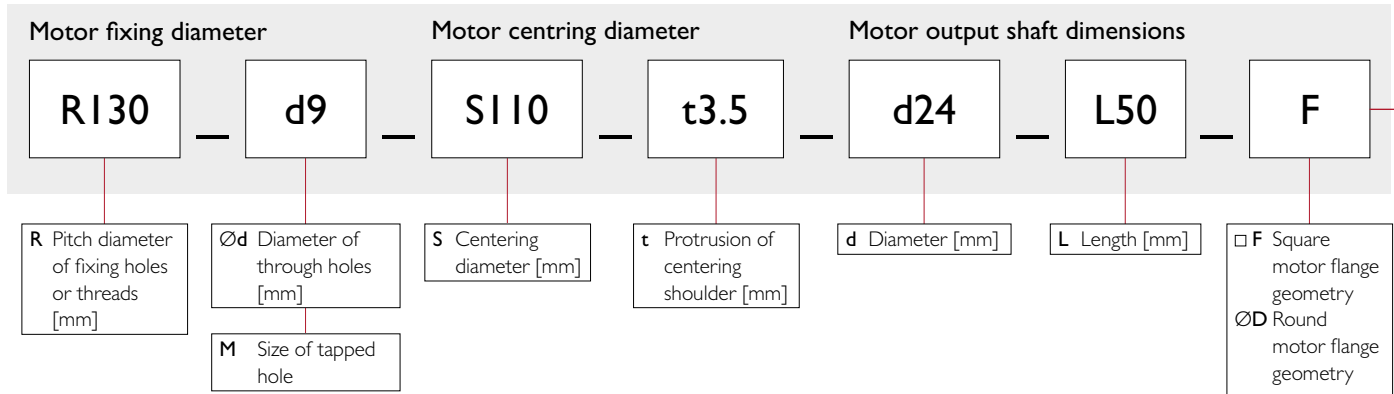

* Motortable pages 84 and 85 apply for $t_s \leq t$.
If $t_s > t$ please contact Güdel.

If desired motor configuration is not in table, please contact Güdel.

Motor					
R	Ød/M	S	t	d	L
63	d 4.5	40	2.5	9	20
63	d 5.4	40	2.5	9	20
63	d 5.5	40	2.5	9	25
64	d 5.4	40	2	9	20
70	d 4.5	40	2.5	9	20
70	d 4.5	50	3	11	30
70	d 4.5	50	3	14	30
70	d 5.5	50	3	14	30
75	d 5.5	60	2.5	11	23

Gearbox size									
030		045		060		090		120	
Coupling	L ^{tot}	Coupling	L ^{tot}	Coupling	L ^{tot}	Coupling	L ^{tot}	Coupling	L ^{tot}
T19	153	T19	184						
T19	153	T19	184						
T19	153	T19	184						
T19	153	T19	184						
T19	153	T19	184						
T19	153	T19	184						
T19	153	T19	184						
T19	153	T24	191						

Motor						Gearbox size									
R	Ød/M	S	t	d	L	030		045		060		090		120	
						Coupling	L ^{tot}	Coupling	L ^{tot}	Coupling	L ^{tot}	Coupling	L ^{tot}	Coupling	L ^{tot}
75	d 5.5	60	2.5	14	30	T19	153	T24	191	T24	232				
75	d 5.5	60	3	14	30	T19	153	T24	191	T24	232				
75	d 5.8	60	2.5	11	23	T19	153	T24	191						
75	d 6.5	60	3	14	30	T19	153	T24	191	T24	232				
90	d 6	70	3	19	35			T24	191	T28	236				
90	d 7	70	3	14	30	T19	153	T24	191	T28	236				
90	d 7	70	3	16	40	T19	160	T24	191	T28	236				
95	d 6.6	50	2.5	14	30	T19	153	T19	184						
100	d 7	80	3	14	30	T19	153	T24	191	T28	236	T28	297		
100	d 7	80	3	19	40			T24	191	T28	236	T28	297		
100	d 6.5	80	2.5	14	30	T19	153	T24	191	T28	236	T28	297		
100	d 6.5	80	3	19	40			T24	191	T28	236	T28	297		
100	d 6.6	80	4	10	32	T19	155	T24	195	T24	232				
100	d 6.6	80	5	14	37	T19	155	T24	195	T28	236	T28	297		
100	d 6.6	80	5	16	40	T19	162	T24	195	T28	236	T28	297		
115	d 9	95	3	19	40			T24	191	T28	236	T28	297	T38	373
115	d 7	95	3	24	45			T24	201	T28	253	T38	317	T38	373
115	d 10	95	3	19	40			T24	191	T28	236	T28	297	T38	373
130	d 9	95	3	19	40			T24	191	T28	236	T28	297	T38	373
130	d 9	95	3	24	50			T24	201	T28	253	T38	317	T38	373
130	d 9	110	3	24	50			T24	201	T28	253	T38	317	T38	373
130	d 9	110	3.5	24	50			T24	201	T28	253	T38	317	T38	373
130	d 9	110	3.5	19	40			T24	191	T28	236	T28	297	T38	373
130	M8	110	3.5	19	40			T24	191	T28	236				
130	M8	110	3.5	24	50			T24	201	T28	253				
130	M8	110	3.5	28	60					T28	269				
145	d 9	110	6	19	55			T24	206	T28	253	T38	318	T38	374
145	d 9	110	6	19	58					T28	253	T38	318	T38	374
145	d 9	110	6	22	58					T28	253	T38	318	T38	374
145	d 9	110	6	24	58					T28	253	T38	318	T38	374
145	d 9	110	6	28	63					T28	269	T38	318	T42	384
145	d 10	110	3.5	16	40			T24	191	T28	236	T28	298	T38	374
145	d 10	110	3.5	19	40			T24	191	T28	236	T28	298	T38	374
165	d 11	110	4	24	50					T28	253	T38	317	T38	373
165	d 11	130	3	28	60					T28	269	T38	317	T42	383
165	d 11	130	3.5	19	28					T28	236	T28	297		
165	d 11	130	3.5	24	50					T28	253	T38	317	T38	373
165	d 11	130	3.5	32	58					T28	269	T38	317	T42	383
165	d 11	130	4	32	58					T28	269	T38	317	T42	383
190	d 11	155	3.5	32	60							T38	317	T42	383
190	d 11	155	3.5	35	60							T38	317	T42	383
200	d 13.5	114.3	3.2	35	79							T38	335	T42	398
200	d 13.5	114.3	3.2	42	113									T42	448
215	d 14	130	4	32	60							T38	317	T42	383
215	d 14	130	4	38	60							T38	335	T42	383
215	d 13	180	4	28	60							T38	317	T42	383
215	d 13	180	4	38	80							T38	355	T42	398
215	d 14	180	4	28	42							T38	317	T38	373
215	d 14	180	4	28	60							T38	317	T42	383
215	d 14	180	4	32	58							T38	317	T42	383
215	d 14	180	4	32	60							T38	317	T42	383
215	d 14	180	4	32	80							T38	335	T42	398
215	d 14	180	4	38	80							T38	355	T42	398
235	d 13.5	200	4	42	116									T42	448
265	d 13	230	4	38	80									T42	398
265	d 14	230	4	38	80									T42	398
265	d 14	230	4	55	110									T42	448
300	d 18	250	5	42	110									T42	425
300	d 18	250	5	48	82									T42	425
300	d 18	250	5	48	110									T42	448
300	d 19	250	5	48	110									T42	448

Calculate your gearbox

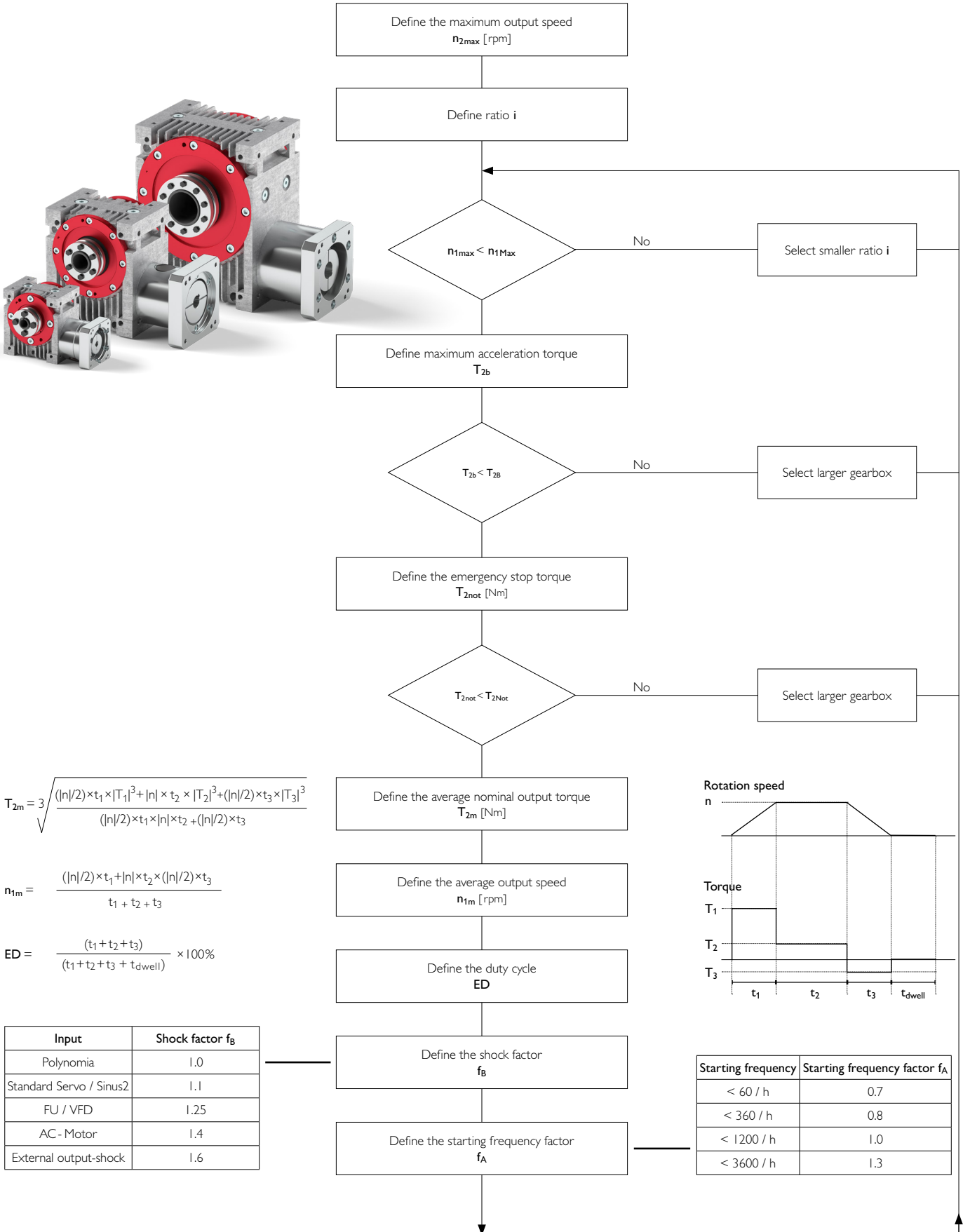

$$T_{2m} = 3 \sqrt{\frac{(|n|/2) \times t_1 \times |T_1|^3 + |n| \times t_2 \times |T_2|^3 + (|n|/2) \times t_3 \times |T_3|^3}{(|n|/2) \times t_1 \times |n| \times t_2 + (|n|/2) \times t_3}}$$

$$n_{1m} = \frac{(|n|/2) \times t_1 + |n| \times t_2 + (|n|/2) \times t_3}{t_1 + t_2 + t_3}$$

$$ED = \frac{(t_1 + t_2 + t_3)}{(t_1 + t_2 + t_3 + t_{dwell})} \times 100\%$$

Input	Shock factor f_B
Polynomialia	1.0
Standard Servo / Sinus2	1.1
FU / VFD	1.25
AC - Motor	1.4
External output-shock	1.6

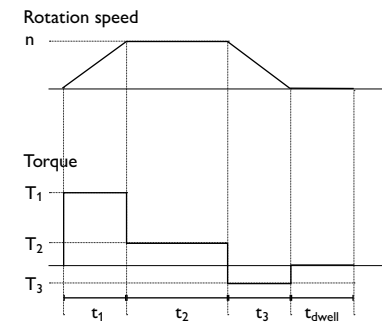

Starting frequency	Starting frequency factor f_A
< 60 / h	0.7
< 360 / h	0.8
< 1200 / h	1.0
< 3600 / h	1.3

	Size				
	030	045	060	090	120
$n_{1m} < 500 \text{ rpm}$	5.50	3.00	1.70	1.10	1.00
$n_{1m} < 1000 \text{ rpm}$	4.00	2.30	1.40	1.05	1.00
$n_{1m} < 1500 \text{ rpm}$	3.30	2.00	1.30	1.05	1.00
$n_{1m} < 3000 \text{ rpm}$	2.30	1.50	1.15	1.05	1.00
$n_{1m} < 4500 \text{ rpm}$	1.70	1.30	1.05	1.00	1.00
$n_{1m} < 6000 \text{ rpm}$	1.50	1.20	1.00		

Abrasion factor f_p^* for high-accuracy applications, otherwise $f_p = 1$.

	Size				
	030	045	060	090	120
$n_{1m} < 500 \text{ rpm}$	0.40	0.40	0.40	0.60	0.80
$n_{1m} < 1000 \text{ rpm}$	0.40	0.40	0.45	0.70	0.90
$n_{1m} < 1500 \text{ rpm}$	0.40	0.40	0.55	0.80	1.20
$n_{1m} < 3000 \text{ rpm}$	0.40	0.40	0.70	0.95 ^{a)}	2.00 ^{a)}
$n_{1m} < 4500 \text{ rpm}$	0.40	0.40	0.70	1.00 ^{a)}	2.80 ^{a)}
$n_{1m} < 6000 \text{ rpm}$	0.40	0.40	0.75		

a) Maximum duty cycle 80%
b) Maximum duty cycle 60%

Mechanical output torque

$$T_{2mech} = T_{2m} \times f_B \times f_A \times f_p^*$$

Thermic output torque

$$T_{2therm} = T_{2m} \times f_{ED} \times f_T \times f_U$$

	Motor limitation				
	030	045	060	090	120
Mass [kg]	6	13	25	50	85
Length [mm]	225	300	375	500	625

d	$T_{NotCoupling}$				
	5903-19	5903-24	5903-28	5903-38	5903-42
9	21				
10	21	35			
12	21	42			
14	21	49	120		
16	21	56	138	241	
18	21	63	155	272	
20	21	70	172	302	
22		75	190	332	
24		75	200	362	
26		75	200	393	
28		75	200	405	371
30		75	200	405	397
32		75	200	405	424
35			200	405	463
38				405	503
42				405	556
48					560
55					560

d: Motor shaft diameter

See table $T_{Coupling}$ on page 84

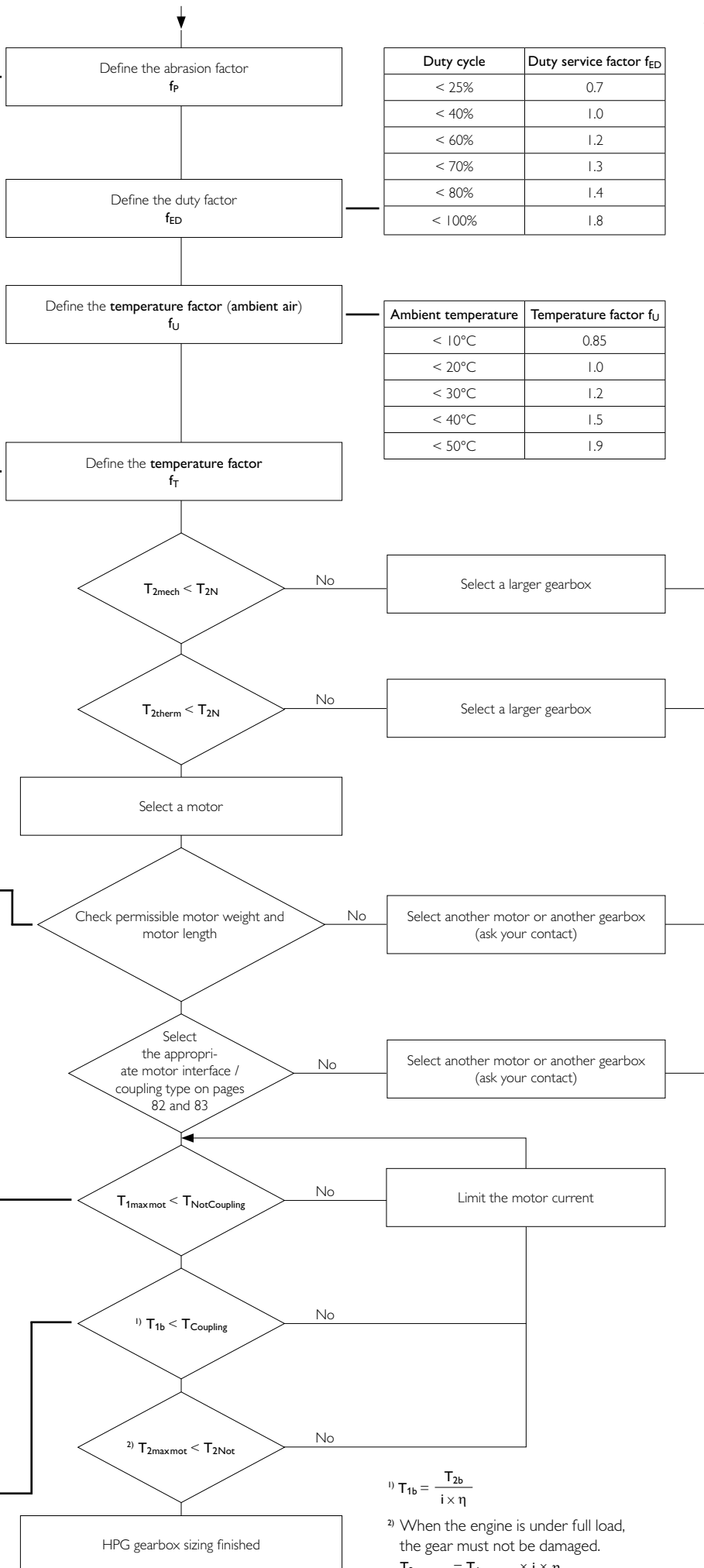

$$^1) T_{1b} = \frac{T_{2b}}{i \times \eta}$$

²⁾ When the engine is under full load, the gear must not be damaged.

$$T_{2maxmot} = T_{1maxmot} \times i \times \eta$$

Find your ideal drive train

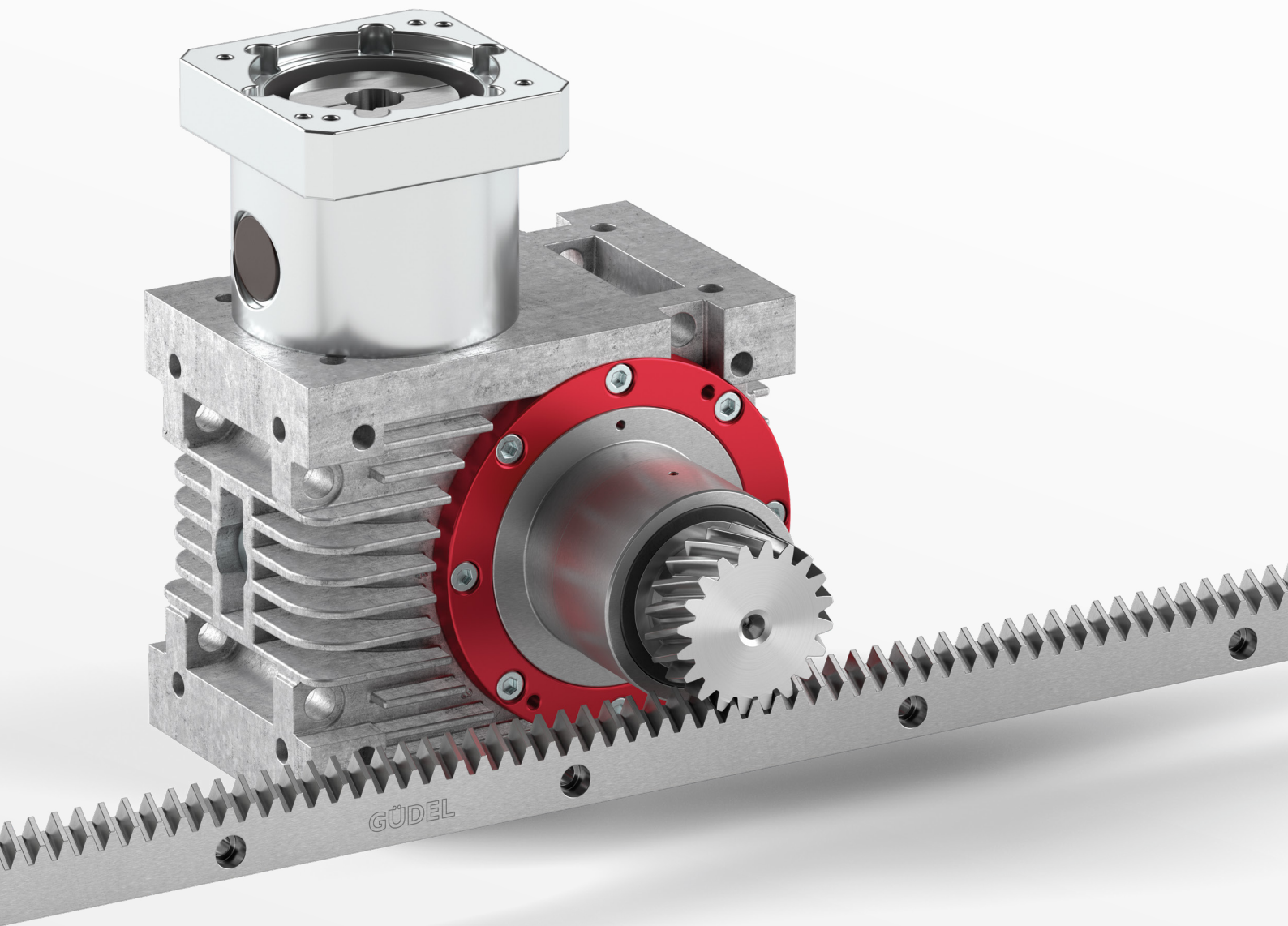

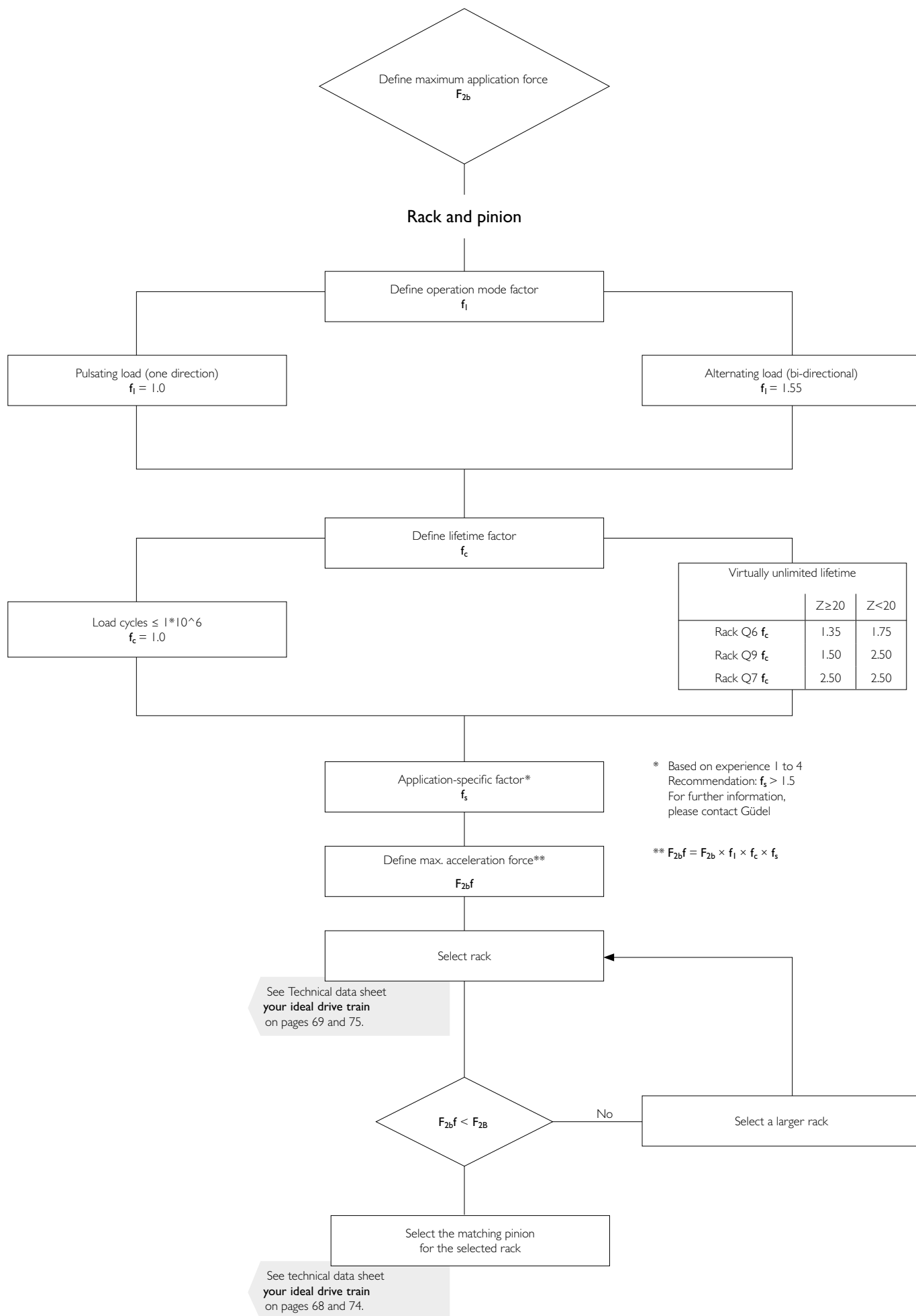

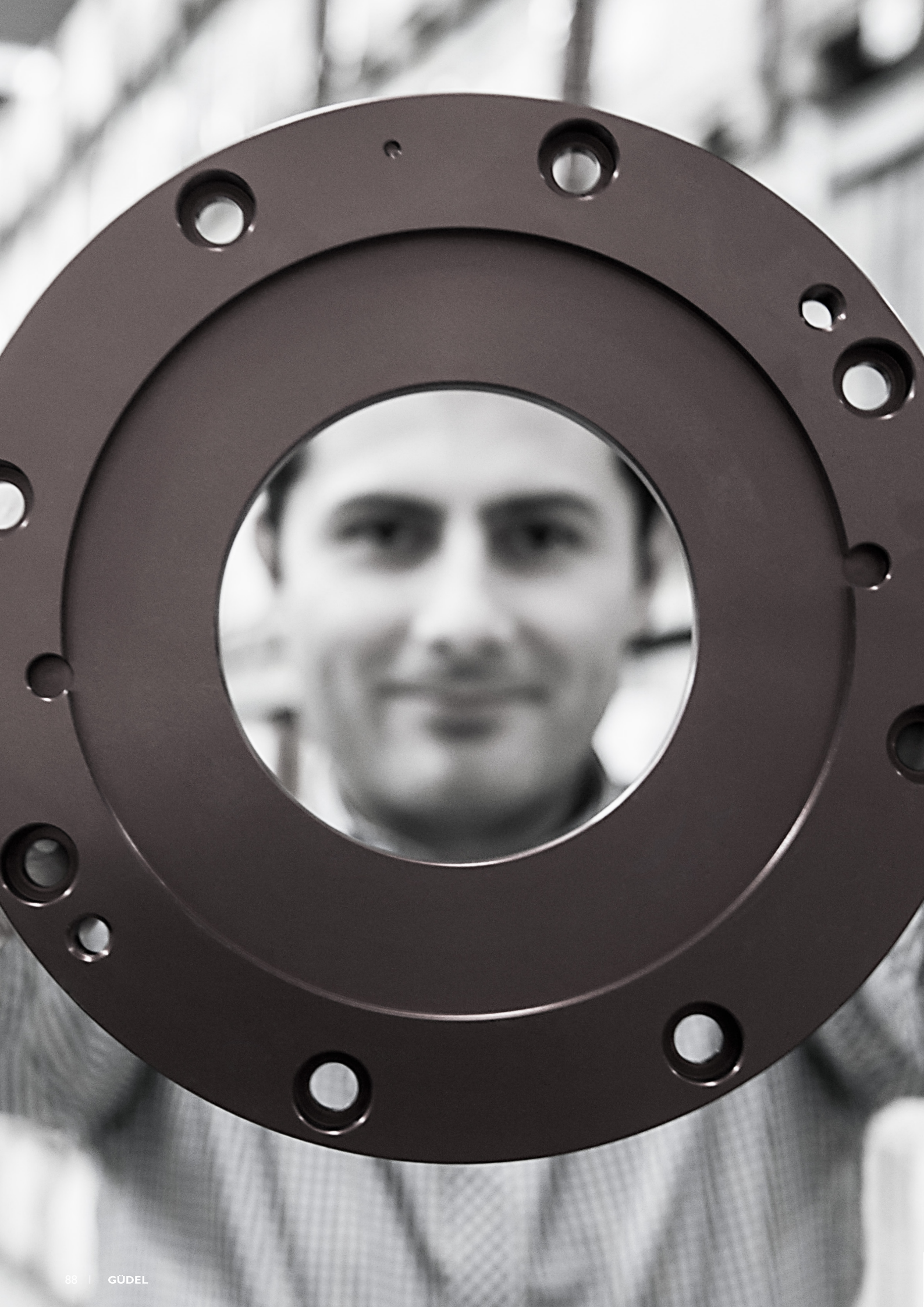

Güdel worldwide

GÜDEL

Contacts

Europe

Switzerland

Güdel Group AG (Headquarters)
Gaswerkstrasse 26
4900 Langenthal
Phone +41 62 916 9191
info@ch.gudel.com

Güdel AG
Gaswerkstrasse 26
4900 Langenthal
Phone +41 62 916 91 91
info@ch.gudel.com

Austria

Güdel GmbH
Schöneringer Strasse 48
4073 Wilhering
Phone +43 7226 20690 0
info@at.gudel.com

Netherlands

Güdel AG
Eertmansweg 30
7595 PA Weerselo
Phone +31 541 66 22 50
info@nl.gudel.com

Czech Republic

Güdel a.s.
Holandská 10
63900 Brno
Phone +420 519 323 431
info@gudel.cz

France

Güdel SAS
Tour de l'Europe 213
3 Bd de l'Europe
68100 Mulhouse
Phone +33 1 69 89 80 16
info@fr.gudel.com

Güdel Sumer SAS
Le Roqual
Zone industrielle
Carsac-Aillac
24200 Sarlat-la-Canéda
Phone +33 5 53 30 30 80
gudel-sumer@fr.gudel.com

Germany

Güdel Germany GmbH
(German Headquarters)
Industriepark 107
74706 Osterburken
Phone +49 6291 6446 0
info@de.gudel.com

Güdel Germany GmbH (Altenstadt)
Carl-Benz-Strasse 5
63674 Altenstadt
Phone +49 6047 9639 0
info@de.gudel.com

Güdel Intralogistics GmbH
Gewerbegebiet Salzhub 11
83737 Irschenberg
Phone +49 8062 7075 0
intralogistics@de.gudel.com

Italy

Güdel S.r.l.
Strada per Cernusco, 7
20060 Bussero (MI)
Phone +39 02 9217021
info@it.gudel.com

Poland

Güdel Sp. z o.o.
ul. Legionów 26/28
43-300 Bielsko - Biała
Phone +48 33 819 01 25
info@pl.gudel.com

Russia

Güdel AG
Yubileynaya 40
Office 1902
445057 Togliatti
Phone +7 8482 775444
info@ru.gudel.com



 **Spain**

Güdel AG
Avinguda de Catalunya 49B
1º 3ª
08290 Cerdanyola del Vallés,
Barcelona
Phone +34 644 347 058
info@es.gudel.com

 **United Kingdom**

Güdel Lineartec (U.K.) Ltd.
Unit 5 Wickmans Drive
Banner Lane
CV4 9XA Coventry, West Midlands
Phone +44 24 7669 5444
info@uk.gudel.com

Americas

 **Brazil**

Güdel Lineartec
Comércio de Automação Ltda.
Rua Américo Brasiliense
nº 2170, cj. 506
Chácara Santo Antonio
São Paulo, CEP 04715 - 005
Phone +41 62 916 91 91
info@ch.gudel.com

 **Mexico**

Güdel TSC S.A. de C.V.
Gustavo M. Garcia 308
Col. Buenos Aires
Monterrey, N.L. 64800
Phone +52 81 8374-2500
info@mx.gudel.com

 **USA**

Güdel Inc.
4881 Runway Blvd.
Ann Arbor, MI 48108
Phone +1 734 214 0000
info@us.gudel.com

Asia Pacific

 **China**

Güdel International Trading Co. Ltd.
Block A, 8 Floor, C2 BLDG
No. 1599 New Jin Qiao Road
Pudong
Shanghai 201206
Phone +86 21 5055 0012
info@cn.gudel.com

 **India**

Güdel India Pvt. Ltd.
Gat no. 458-459
Mauje Kasar Amboli
Pirangut, Tal.Mulshi
Pune 412 111
Phone +91 20 679 10200
info@in.gudel.com

 **South Korea**

Güdel Lineartec Inc.
7-15 Incheon tower
daero 25beon gil.
Post no. 22013
Yeonsu gu Incheon
Phone +82 32 858 0541
info@kr.gudel.com

 **Taiwan, China**

Güdel Lineartec Co. Ltd.
No. 99, An-Chai 8th St.
Hsin-Chu Industrial Park
30373 Hu-Ko, Hsin-Chu
Phone +88 635 97 8808
info@tw.gudel.com

 **Thailand**

Güdel Lineartec Co. Ltd.
19/28 Private Ville Hua Mak Road
Hua Mak Bang Kapi
10240 Bangkok
Phone +66 2 374 0709
info@th.gudel.com

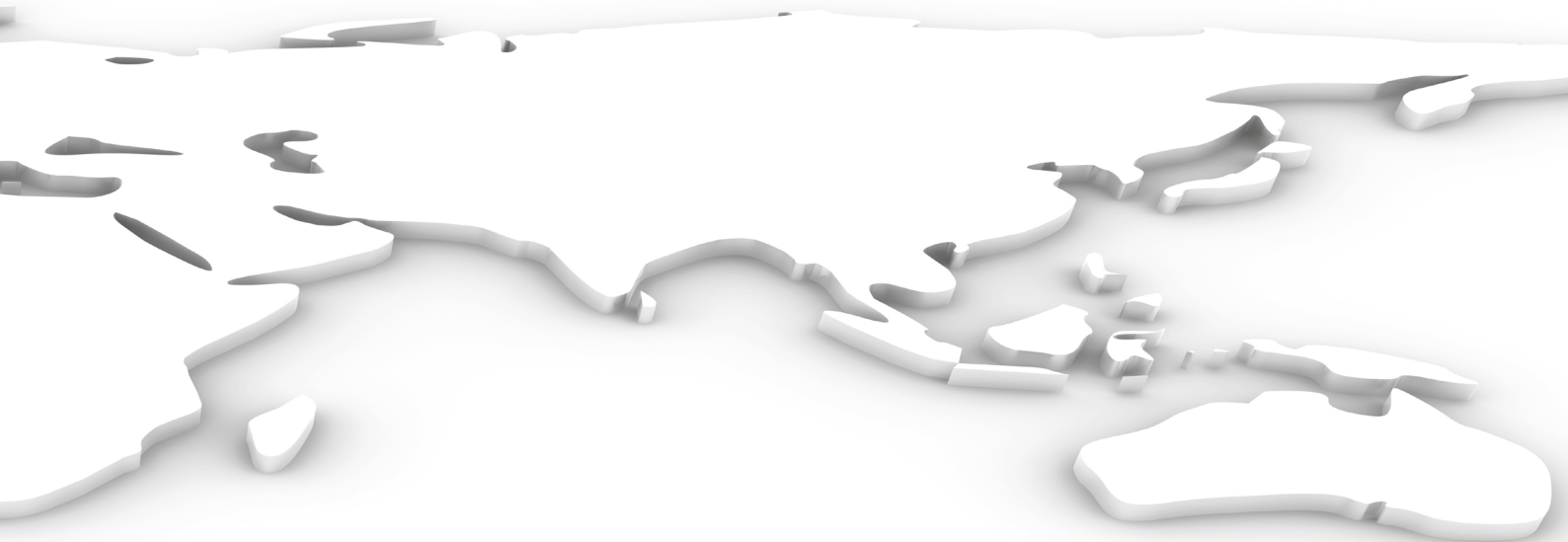

© Güdel AG

We have taken the greatest care in compiling this catalog with specifications and technical information. Please understand that we accept no liability for misprints, technical changes, or consequential damage in relation to the published information. The catalog is purely for information purposes, so the illustrations and information in no way represent guaranteed properties. The text, photos, drawings, and any other display formats in this catalog are intellectual property of Güdel AG. Please note that any duplication, editing, translation, saving, or any other subsequent use of the catalog or its components in print or electronically may only be carried out with the previous, express consent of Güdel AG. Güdel AG reserves the right to modify the provided information at any time in order to always be able to present you with the most up-to-date version of our catalog and products.

