

GÜDEL

Customer Service

Experience and competence from a single source



Our company profile

The Güdel Group is a manufacturer of high-precision machine components and provider of sophisticated automation solutions. Its spectrum of products ranges from linear guide-ways, racks, pinions, and gearboxes right through to linear axis and gantry robots. Güdel assembles its products into systems with a high degree of control intelligence and complete plant installations, which can be used in the automotive, tire, metal,

rail, intralogistics, pharmaceutical, renewable energy, wood and aerospace industries. The Güdel Group has a workforce of approximately 1,200 employees worldwide in over 30 locations. The Group has been owned by the same family since its foundation more than 60 years ago. The Güdel Group has its headquarters in Switzerland.



Güdel Service

As a Güdel customer and owner of a Güdel system, you are very important to us. We listen to your feedback and provide optimum support for your system. We have a broad understanding of the entire product range and application areas, from components to system integration.

Our promise

We would like to offer our customers a comprehensive, proactive, and value-based service, and this is exactly what we focus our services on. For us, customer service means bundling your various requirements into a suitable overall package. Thanks to our modular system, you will always receive services that are tailor-made for you. We make no difference between Basic, Plus, and Premium. We offer each of our customers individual, first-class customer service.

Our service model

Increasing productivity and decreasing downtime of systems and machinery are only possible with reliable servicing. We will support, protect, and improve your system, thereby ensuring smooth production processes.

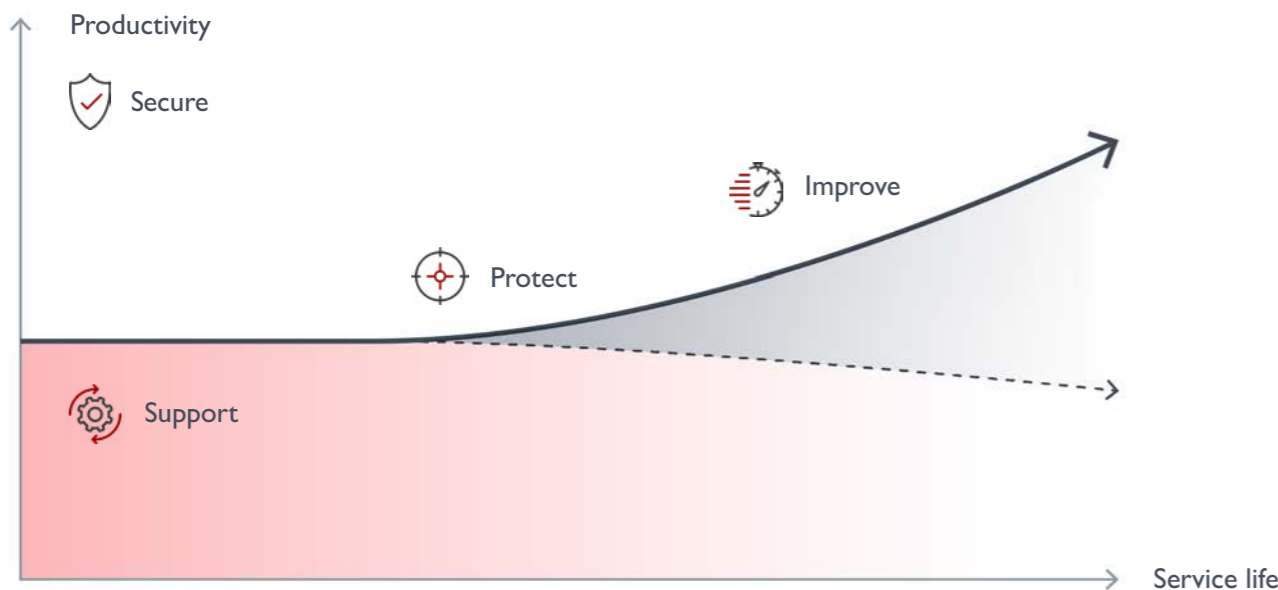

Support

- Care and support for the system during its entire life cycle
- Spare parts from a single source

In the event of malfunctions, we can be reached by phone around the clock, will identify faults via remote maintenance and bring the system quickly back into operation.



Protect

- Value-preserving measures
- Analysis of the system's condition

We maintain your system, replace wear parts, and plan maintenance work. Regular inspections reveal weak spots before disruptions occur.



Improve

- Achieve appreciation and create added value
- Increase productivity and efficiency
- Training courses for professional operation

We optimize the system's processes and workflows. We use extension and modern solutions to convert systems for new requirements.



Secure

- Contractual protection
- Secure benefits
- Comprehensive service

We work with you to identify your requirements and put together a suitable group of service products. As a result, you can plan all maintenance and support activities for the immediate and long term. Our specialists examine the system during regular inspections and maintenance visits and recommend preventive measures.

Modern contract management – the benefits for you

The contractual agreement provides you with comprehensive protection and guarantees you services at specific times – for example preferred time slots during public holidays. You define your service modules for yourself. You can plan and budget your support and maintenance costs for the immediate and long term. As a result, you will minimize your risk of downtimes and receive continuous maintenance in

line with a defined checklist. This list and the maintenance record provide you with important information for preserving and enhancing the value of your system. As a contract customer, you will have special conditions for inspections and maintenance work. You will receive optimum support and regular care of your system.

From the components through to the system solution



Our building blocks

For optimal usage of your system

Güdel has products, solutions, and services to keep our customers' production processes flowing. Because if you want an efficient – and therefore more competitive – production process, it has to flow. We call it Work in FlowMotion.



Spare parts

We reliably supply spare parts all over the world. As support, we offer advice on optimum local warehousing, and recommend the spare parts and wear parts package best suited to your system.

Repair

Smooth production processes based on fast and reliable repair. Our specialists access the system data and perform a quick service. We get to the bottom of malfunctions, perform analyses, and target and fix errors for the long term.

Component refurbishment

Because of our vertical integration expertise we understand the functionality of each component. This allows us a professional overhaul of assemblies, so that it can be used more efficiently for the long term.

Maintenance

With preventive maintenance, we are able to provide an uninterrupted operation of your plant.

Inspection

During a general inspection, we analyze the condition of your system. In the process, we identify defects and weak spots at an early stage, and can define necessary measures.

Wear part packages

Wear parts that need to be replaced regularly are grouped together for you into tailored packages according to your needs.

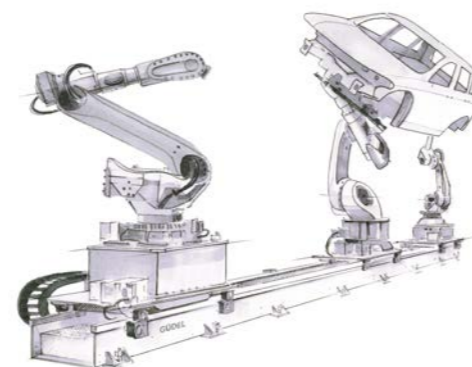

Retrofit

We would like to help you get the best out of your system.

We analyze your processes, advise you, and work with you to define measures for achieving the best out of your system and increasing performance and availability.

We offer you

- Modernization
- Extension
- Optimization

Training

To help you operate and look after your system as efficiently as possible, we run individual, on-site training sessions, or at Güdel upon request.

Production support

After commissioning and the start of production, we provide support with operating your system to ensure a smooth production process.

Service agreement

With your tailor-made service package, you will receive contractually defined elements.

- Preventive maintenance
- General inspection
- Helpline Plus * and remote access
- Wear part packages customized to your needs

* Technical support with contractually defined availability and response times

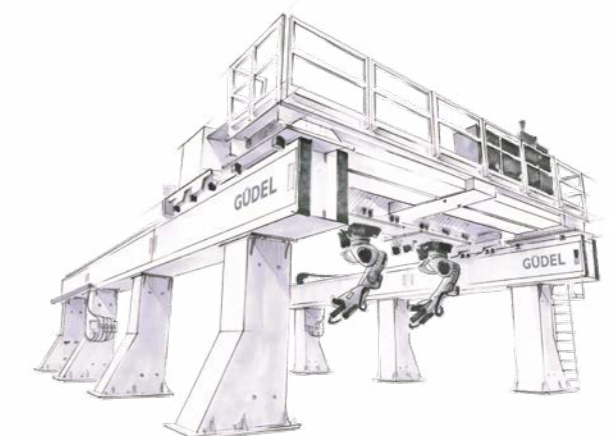

Manufacturing expertise

Everything from a single source

From its beginnings right up to the present day, Güdel has always boasted an exceptional degree of manufacturing depth. The extremely wide range and the overall expertise as solution provider is impressive. This knowledge and our experience constantly flow into the development and production of the individual assemblies.

- | | | |
|-----------------------|--------------|--------------------|
| ■ Components | ■ Experience | } Customer Service |
| ■ Systems | ■ Innovation | |
| ■ Gantries | ■ Constancy | |
| ■ Conveying equipment | ■ Quality | |



Our proximity to our customers ensures that improvements are continuously incorporated into new Güdel products. We learn from the system's operation, and allow these insights to flow into the research and development of our components, as well

as the product management. As a result, our components ensure that the system runs smoothly. We use data from the solutions placed into operation to analyze their condition and optimize performance.

Benefit from our expertise for example in

Spare parts



Installing original spare parts

- Reliable
- Tailor-made
- Constantly upgradeable
- Improve durability
- Direct from the manufacturer

Maintenance



Competently maintaining systems

- Extend service life
- Maintain system's value
- Set maintenance intervals
- Replace wear parts
- Create maintenance records
- Affordable predictability
- Ensure quality

Retrofit



Retrofitting and modernizing systems

- Minimize downtimes
- Modernize system
- Retrofit during production
- Competent for complete systems and system solutions

Worldwide yet local

Service network

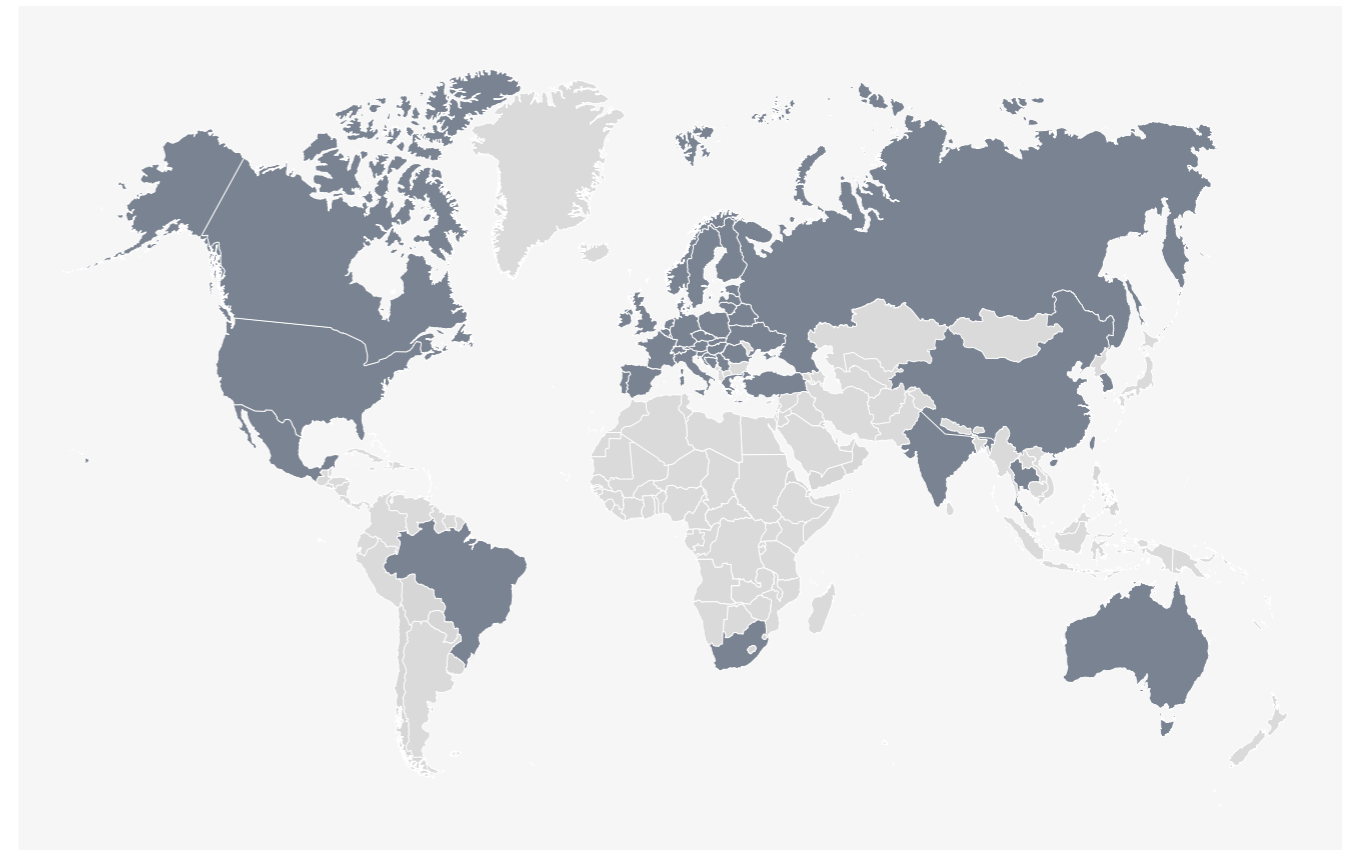

Güdel has a global service network – we look after your system on site

Güdel near you

Our customers' satisfaction is our mission and motivation at the same time. To keep response times short and increase availability, our service engineers are in action all over the world. Our service network extends from the Americas, across Europe, and across to Asia.

You can find our service entities at:
gudel.com

Get ready for the future

Industry 4.0, Internet of Things, Maintenance 4.0 and condition monitoring are important developments for the future. We are working on smartServices solutions on these topics. As our customer, you will be the first to benefit from new technologies and applications.



Smart glasses for repair services

GÜDEL

Do you know that feeling? Everything's running without a hitch. You have a smooth workflow. And you're even producing excellent results. This is what we call „Flow“.

Güdel brings flow to industrial automation by delivering intelligent motion solutions. For less disruptions and inefficiencies. For more performance in less time. For really fluid production processes. Work in Flow-Motion.

Güdel AG
Gaswerkstrasse 26
Industrie Nord
4900 Langenthal
Switzerland
service@ch.gudel.com

We are at your service. Worldwide.

gudel.com

